

TANDEMBOX 358N

Platzbedarf / space requirement / encombrement

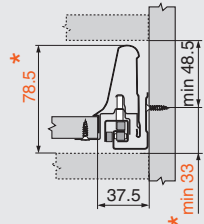

Einbaumaße / installation dimensions / dimensions de montage

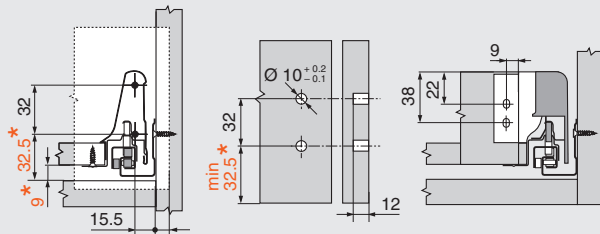

* zusätzlich 2 mm in Kombination mit BLUMOTION Z70.XXX
 plus 2 mm in combination with BLUMOTION Z70.XXX
 2 mm supplémentaires en combinaison avec BLUMOTION Z70.XXX

Befestigungspositionen / fixing positions / positions de fixation

358N / 358M

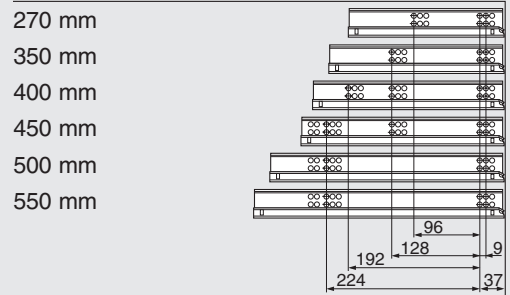

359M / 359K

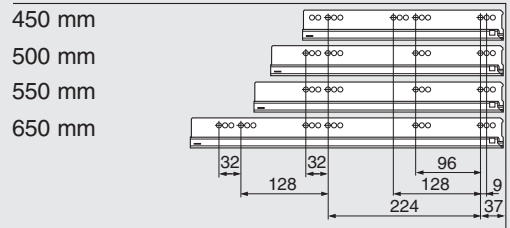

TANDEMBOX 358M

Platzbedarf / space requirement / encombrement

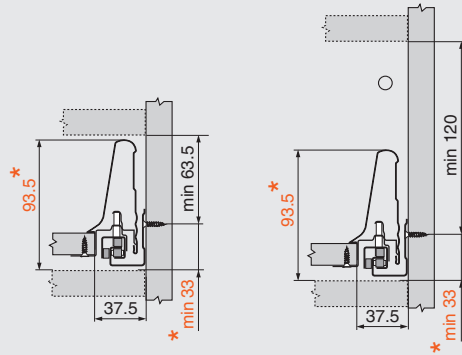

Einbaumaße / installation dimensions / dimensions de montage

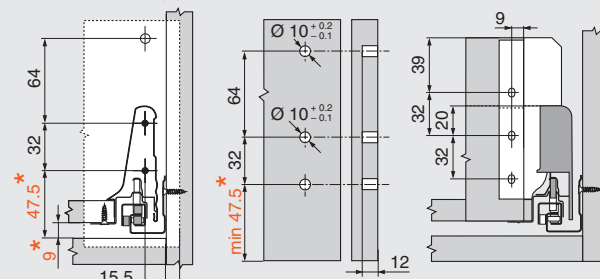
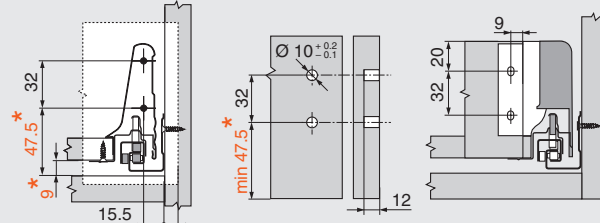

* zusätzlich 2 mm in Kombination mit BLUMOTION Z70.XXX
 plus 2 mm in combination with BLUMOTION Z70.XXX
 2 mm supplémentaires en combinaison avec BLUMOTION Z70.XXX

Berechnung Vorderstück Innenschubkasten
 calculation front piece inner drawer
 calculatoin face avant pour tiroir à l'anglaise

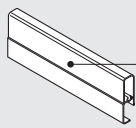

Breite = lichte Korpusweite - 87 mm
 width = internal cabinet width - 87 mm
 largeur = larg. inter. du corps de meuble - 87 mm
 Höhe / height / hauteur = 58.9 mm

TANDEMBOX 358K

Platzbedarf / space requirement / encombrement

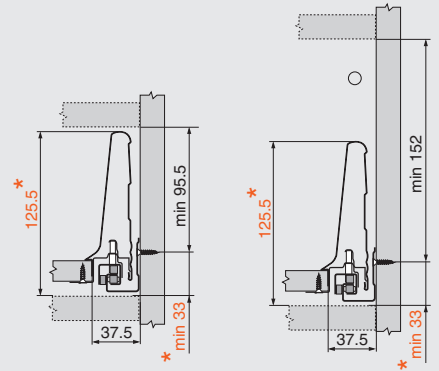

Einbaumaße / installation dimensions / dimensions de montage

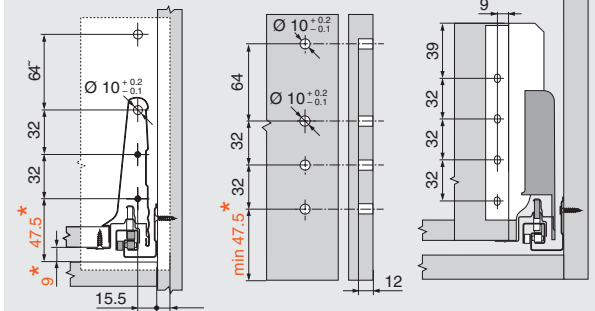
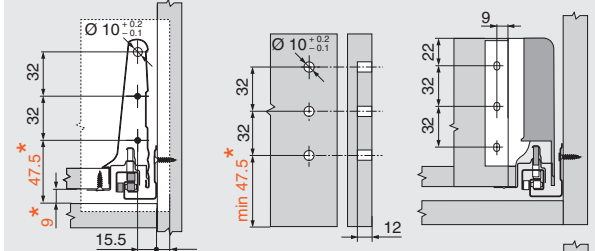

* zusätzlich 2 mm in Kombination mit BLUMOTION Z70.XXX
 plus 2 mm in combination with BLUMOTION Z70.XXX
 2 mm supplémentaires en combinaison avec BLUMOTION Z70.XXX

Julius Blum GmbH
 Beschlägefabrik
 A-6973 Höchst, Austria
 Tel.: 05578/705-0
 Telefax: 05578/705-44

Technische Änderungen vorbehalten
 Subject to technical changes without notice
 Modifications techniques réservées



IDNR: 457.214.0 MA-145/05.02 I

Montage, Bedienung, Verstellung / assembly, handling, adjustment / montage, application, réglage

Front / front / façade

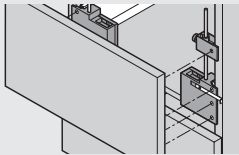

ZML.3500

ZML.3510

ZML.3800

Korpus / carcass / corps de meuble

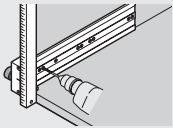

T65.5000

einhängen / insert / accrocher

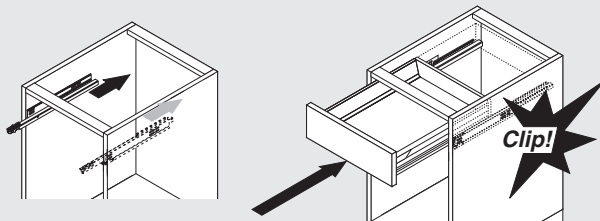

aushängen / remove / décrocher

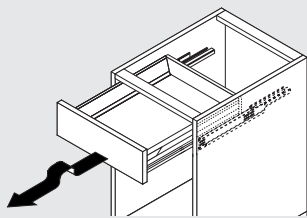

Montage / montage / réglage

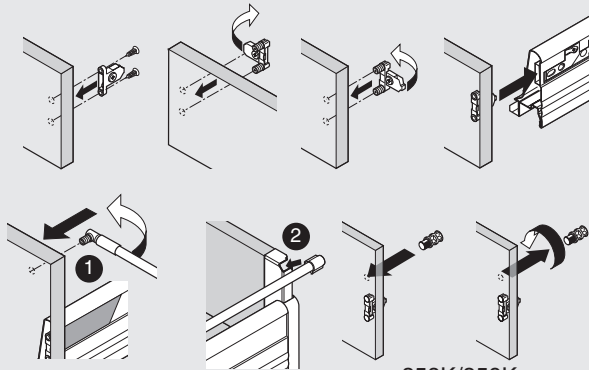

358K/359K

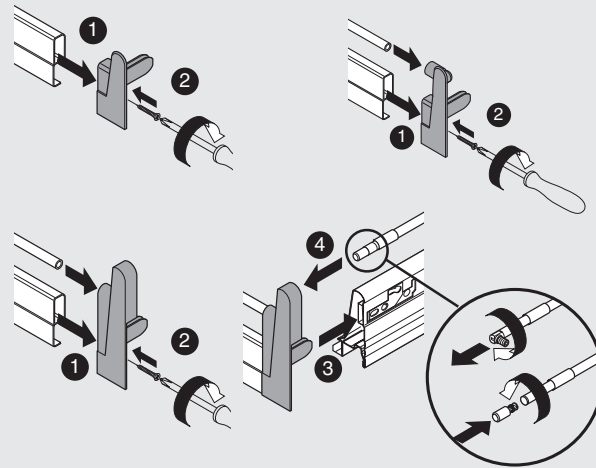

Demontage / dismantling / démontage

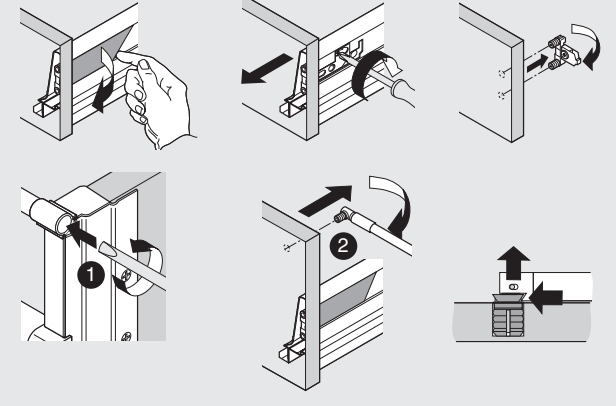

seitlich verstellen / lateral adjustment / réglage latéral

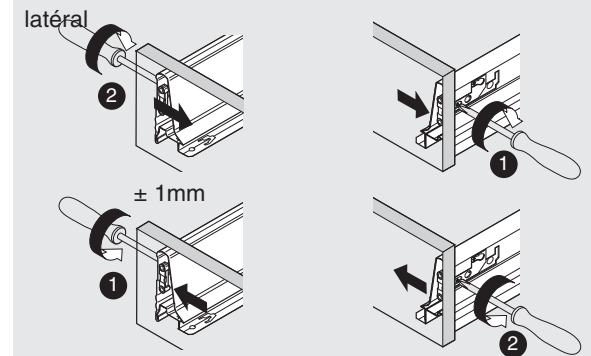

Höhe verstellen / height adjustment / réglage en hauteur

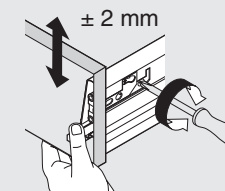

Neigung verstellen / tilt adjustment / réglage de l'inclinaison

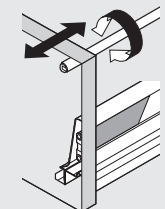

Zuschnittmaße für 16 mm Spanplatten / cutting dimensions for 16 mm components / débit pour panneaux en 16 mm

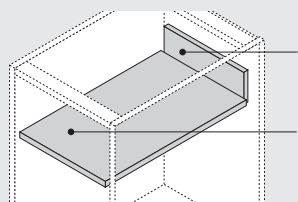

Breite = lichte Korpusweite - 87 mm / width = internal cabinet width - 87 mm / largeur = largeur intérieure du corps de meuble - 87 mm

Höhe / height / hauteur: 358N = 69 mm; 358M = 84 mm; 358M = 135 mm

Breite = lichte Korpusweite - 75 mm / width = internal cabinet width - 75 mm / largeur = largeur intérieure du corps de meuble - 75 mm

Länge = Zargenlänge - 24 mm / length = drawer length - 24 mm / longueur = longueur du tiroir - 24 mm