

SERVO-DRIVE

Ordering and
planning information



The electronic motion support system for pull-outs and wall cabinets

A light touch suffices and pull-outs and wall cabinets seem to open by themselves. For base cabinets, wall cabinets and appliance cabinets. With SERVO-DRIVE, SERVO-DRIVE uno and SERVO-DRIVE flex. One system for the whole kitchen with tailored solutions for all requirements.

Contents

- 04 SERVO-DRIVE/SERVO-DRIVE uno component overview
- 06 SERVO-DRIVE for box and runner systems
- 30 SERVO-DRIVE for box systems
- 36 SERVO-DRIVE for box and runner systems
- 42 SERVO-DRIVE for runner systems
- 58 SERVO-DRIVE uno | Bottom mount waste bin solution
- 62 SERVO-DRIVE uno | Top mount waste bin solution
- 64 SERVO-DRIVE | Assembly devices
- 66 SERVO-DRIVE flex component overview
- 68 SERVO-DRIVE flex | Refrigerators and freezers
- 74 SERVO-DRIVE flex | Fridge/freezer combinations
- 76 SERVO-DRIVE flex | Dishwashers
- 78 moving ideas



Blum distance bumper

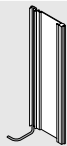

The Blum distance bumper ensures the required trigger path of 2 mm.

Bracket profile

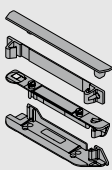
The drive units are attached to the bracket profile.

Bracket profile attachment and bracket profile cover cap

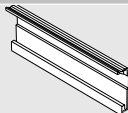
These components are used to attach the bracket profile to a horizontal and/or vertical cross member.

Horizontal bracket profile

The drive unit is attached to the bracket profile using the bracket profile adapter.

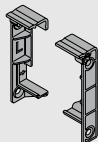
Bracket profile attachment

This component is used for attaching the horizontal bracket profile.

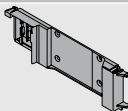
Bracket profile adapter for drive unit

The adapter is used to attach the drive unit to the horizontal bracket profile.

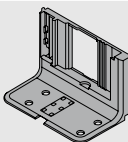
Attachment bracket 1 tier

You can use attachment brackets if single pull-outs are to be operated or if the installation situation does not permit a continuous bracket profile.

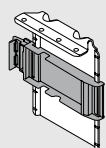
Upper attachment bracket with pre-assembled adapter for the drive unit

The drive unit is fixed to the adapter for the upper attachment bracket.

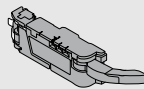
Drive unit

The drive unit is supplied with a lever extension. The lever extension must be removed in special applications such as narrow cabinets so that the drive unit can be installed (see planning information).

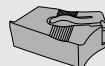
Lever cap for LEGRABOX

Prevents collision with the LEGRABOX steel back from height M with an internal cabinet width LW of 267–286 mm.

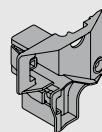
Trigger guidance for TANDEMBOX

Prevents the lever from colliding with TANDEMBOX back fixing (LW 242-316 mm), in combination with a chipboard back.

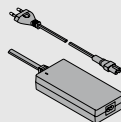
SERVO-DRIVE power supply unit

The SERVO-DRIVE power supply unit can be used around the world. It converts the country-specific mains voltage to 24 V direct current. You must use a flex with a regular plug for the respective country. The SERVO-DRIVE power supply unit is used to supply several drive units with power (throughout the entire kitchen).

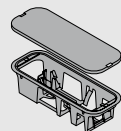
Power supply unit housing
Base fixing

The power supply unit housing for base fixing securely accommodates the SERVO-DRIVE power supply unit on the base of the cabinet.

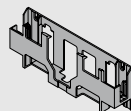
Power supply unit housing
Back panel/wall fixing

The SERVO-DRIVE power supply unit can be attached to the wall or back panel with the power supply unit housing for back panel/wall fixing.

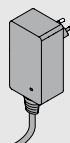
SERVO-DRIVE plug-in power supply unit

The SERVO-DRIVE plug-in power supply unit supplies power to a single drive unit (single application).

SERVO-DRIVE distribution cable



The distribution cable supplies power to the drive units. The max. permitted operating voltage is 24 V.

Note: This cable must not be directly connected to the mains power outlet.

Connecting node

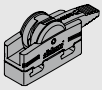

This node establishes the electrical connection between the SERVO-DRIVE distribution cable and the bracket profile and/or the SERVO-DRIVE power supply unit.

Cable end protector

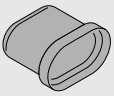

The cable end protector is fitted onto the unused ends of the cable.

Drip protection feature for attachment bracket 1 tier

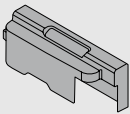

The drip protection feature prevents water from penetrating the SERVO-DRIVE drive unit. Suitable for applications with an attachment bracket 1 tier.

Drip protection feature for horizontal applications

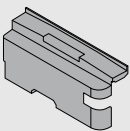

The drip protection feature prevents water from penetrating the SERVO-DRIVE drive unit. Suitable for applications with a horizontal bracket profile.

Locating bracket



No pre-drilling, self-adhesive
For positioning the SERVO-DRIVE uno unit.

Steel back height M

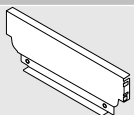

Steel back for TANDEMBOX – top mount waste bin solution.

Steel back for waste bin pull-out

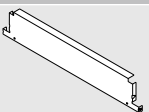

Special back for TANDEMBOX – top mount waste bin solution.

Attachment left/right

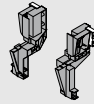

These components are used to attach the steel back for TANDEMBOX – top mount waste bin solution.

Rectangular longside gallery rail left/right

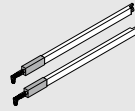

Gallery can be used in combination with TANDEMBOX.

Transport protection

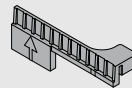

Serves to protect the SERVO-DRIVE uno set during transportation. Remove before use.

Accessories

Cable holder

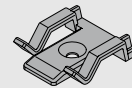

The cable holder allows you to route the SERVO-DRIVE distribution cable safely and neatly.

Front/base stabiliser

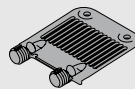

For TANDEMBOX:

Stabilises wide and high fronts. Reinforces the connection between drawer side and front.

For LEGRABOX/MERIVOBX:

Stabilises wide drawer bases. Reinforces the connection between base and front.

Synchronisation cable



The synchronisation cable allows you to synchronise two interconnected drive units.

Colour/material

WGR	White grey	R7035	RAL 7035 light grey
SZ	Black	R7037	RAL 7037 dust grey
WS	White	K	Nylon
TGR	Dark grey	ZN	Zinc plated



SERVO-DRIVE can be used in combination with AMPEROS AC from a minimum internal width of 562 mm.

Standard cabinet with horizontal and vertical cross members

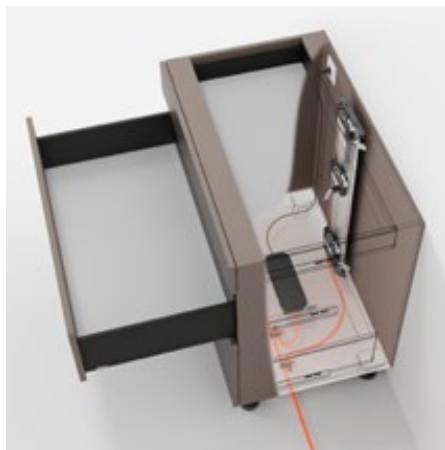

- Electrical motion support system in combination with BLUMOTION for soft and effortless closing
- With vertical bracket profile
- No fixed connection between the drive unit and pull-out
- Pull-outs need not be modified
- Tool-free drive unit assembly
- Simple cabling
- Shallow installation depth

Space requirement

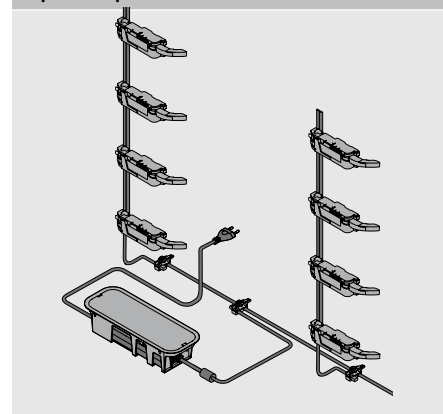

Ordering information

Blum distance bumper			
	Ø (mm)	Colour	
	5	TGR	993.0530
	8	TGR	993.0830.01
Up to front height 300 mm, use 2 pcs			
From front height 300 mm, use 4 pcs			
For LEGRABOX/MERIVOBX 70 kg cabinet profile, use 4 pcs			
For TANDEMBOX 65 kg cabinet profile, use 4 pcs			

Bracket profile			
	Bracket profile with SERVO-DRIVE distribution cable		
	Length (mm)		
	650	Z10T650AA	Z10T750AA
	700	Z10T700AA	Z10T800AA
	710	Z10T710AA	
	Bracket profile without SERVO-DRIVE distribution cable		
	Length (mm)		
	1170		Z10T1170A
Aluminium for cutting to size			
Cutting:	Internal cabinet height LH - 10 mm		

Bracket profile attachment top/bottom			
	Horizontal cross member		
	Colour	Material	
	TGR	K	Z10D01E0.01

Alternative to 3

Bracket profile attachment bottom/back			
	Vertical cross member		
	Colour	Material	
	TGR	K	Z10D01EA.01

Drive unit			
	Colour	Material	
	TGR	K	Z10A3000.04
Incl. pre-mounted lever extension			

Lever cap for LEGRABOX			
	Colour	Material	
	SZ	K	Z10A3006
Steel back			
Required from height M and internal cabinet width LW of 267–286 mm			

Trigger guidance for TANDEMBOX			
	Colour	Material	
	R7037	K	Z10A3H00
Chipboard back			
Required for an LW of 242–316 mm			

SERVO-DRIVE distribution cable and cable end protector			
	Colour	Length (m)	
	SZ	8	Z10K800AE

Consisting of:

1x SERVO-DRIVE distribution cable

5x cable end protectors

For cutting to size

Can be used as distribution, bracket profile and communication cable

Standard cabinet with horizontal and vertical cross members

	Connecting node and cable end protector		
	Colour	Material	
	SZ	K	Z10V100E.01
Consisting of:			
1x connecting node			
2x cable end protectors			

SERVO-DRIVE power supply unit incl. flex					

Markets	Language packages		Markets	Language packages	
E	A	Z10NE04EA	I	A	Z10NE04IA
E	B	Z10NE04EB	K	I	Z10NE04KI
E	C	Z10NE04EC	N	H	Z10NE04NH
E	D	Z10NE04ED	R	H	Z10NE04RH
E	E	Z10NE04EE	S	K	Z10NE04SK
E	F	Z10NE04EF	T	H	Z10NE04TH
E	I	Z10NE04EI	U	G	Z10NE04UG
B	A	Z10NE04BA	U	J	Z10NE04UJ
B	I	Z10NE04BI	Z	I	Z10NE04ZI
H	I	Z10NE04HI			

Incl. operating and installation instructions

Consisting of:

1 x	Power supply unit (output flex: length 2 m)
- 1 x	Flex (1.5–1.8 m, incl. plug)

Markets and language packages

Code	
Markets	Language packages*
E Europe	A DE, EN, FR, IT, NL
B GB	B DA, EN, FI, NO, SV
H IN	C EL, EN, HR, SR, SL, TR
I IL	D EN, ES, FR, IT, PT
K AU	E CS, HU, PL, SK
N CN	F BG, ET, LV, LT, RO, RU, GB
R KR	G EN, ES, FR
S BR	H EN, ZH, KO
T TW	I EN
U US CA JP	J JA
Z ZA	K EN, ES, PT

* Language code according to the ISO 639 standard

	Power supply unit housing		
	Base fixing		
	Colour	Material	
	TGR	K	Z10NG000
Incl. cover			
For SERVO-DRIVE power supply unit			

Alternative

	Power supply unit housing		
	Back panel/wall fixing		
	Colour	Material	
	WGR	K	Z10NG120
For SERVO-DRIVE power supply unit			

Accessories

	Cable holder		
	Colour	Material	
	WS	K	Z10K0009
E.g. for fixing the SERVO-DRIVE distribution cable			

	Front/base stabiliser		
	Colour	Material	
	R7037	K	Z96.10E1

	Synchronisation cable		
	Length (mm)		
	80		Z10K008S
	500		Z10K050S
	1200		Z10K120S
	1600		Z10K160S
Connects two drive units that need to open simultaneously			

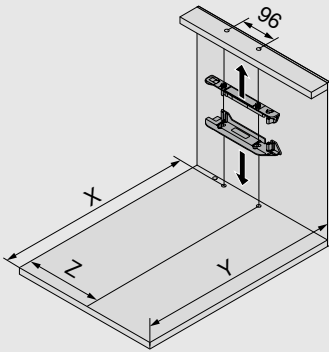
Standard cabinet – horizontal cross member
Planning
Drilling distances – cabinet base | cross member

Drawer back – box systems	X (mm)	Y (mm)
Chipboard back	NL + 19	NL + 33
Steel back	NL + 2	NL + 16

NL Nominal length

X Drilling position

Y Min. space requirement

Z Dimension of engagement

Drawer back – runner systems	X (mm)	Y (mm)
≥ 79	NL + 16	NL + 30

Box system	Back	Back height	Internal cabinet width LW (mm)									
			242–266			267–286				287–316		
			Z (mm)	Lever extension	Trigger guidance	Z (mm)	Lever extension	Trigger guidance	Lever cap	Z (mm)	Lever extension	Trigger guidance
LEGRABOX	Chipboard back	N	–	–	–	184	●	–	–	184	●	–
		M K C F	–	–	–	184	●	–	–	184	●	–
	Steel back	N	–	–	–	–	–	–	–	–	–	–
		M K C F	–	–	–	184	✘	–	●	184	●	–
MERIVOBX	Chipboard back	N	–	–	–	174	✘	–	–	174	●	–
		M K E F	–	–	–	174	✘	–	–	174	●	–
	Steel back	N	–	–	–	–	–	–	–	–	–	–
		M K E F	–	–	–	174	●	–	–	174	●	–
TANDEMBOX	Chipboard back	N	179	✘	●	179	●	●	–	179	●	●
		M K B C D	179	✘	●	179	●	●	–	179	●	●
	Steel back	N	–	–	–	–	–	–	–	190	✘	–
		M K B C D	–	–	–	179	✘	–	–	179	●	–

Box system	Back	Back height	Internal cabinet width LW (mm)					
			317–386			≥ 387		
			Z (mm)	Lever extension	Trigger guidance	Z (mm)	Lever extension	Trigger guidance
LEGRABOX	Chipboard back	N	184	●	–	LW / 2	●	–
		M K C F	184	●	–	LW / 2	●	–
	Steel back	N	–	–	–	–	–	–
		M K C F	184	●	–	LW / 2	●	–
MERIVOBX	Chipboard back	N	174	●	–	LW / 2	●	–
		M K E F	174	●	–	LW / 2	●	–
	Steel back	N	–	–	–	–	–	–
		M K E F	174	●	–	LW / 2	●	–
TANDEMBOX	Chipboard back	N	179	●	○	LW / 2	●	○
		M K B C D	179	●	○	LW / 2	●	○
	Steel back	N	190	●	–	LW / 2	●	–
		M K B C D	179	●	–	LW / 2	●	–

LW Internal cabinet width

○ Not required

Z Dimension of engagement

– Not possible

● Required

✘ Remove

Standard cabinet – horizontal cross member

Runner system	Drawer height SKH (mm)	Internal cabinet width LW (mm)							
		224–234		235–388		389–428		≥ 429	
		Z (mm)	Lever extension	Z (mm)	Lever extension	Z (mm)	Lever extension	Z (mm)	Lever extension
MOVENTO	≥ 79	–	–	164	●	164	●	LW / 2	●
TANDEM	≥ 79	164	–	164	●	LW / 2	●	LW / 2	●

LW Internal cabinet width
 Z Dimension of engagement
 ● Required
 – Not possible

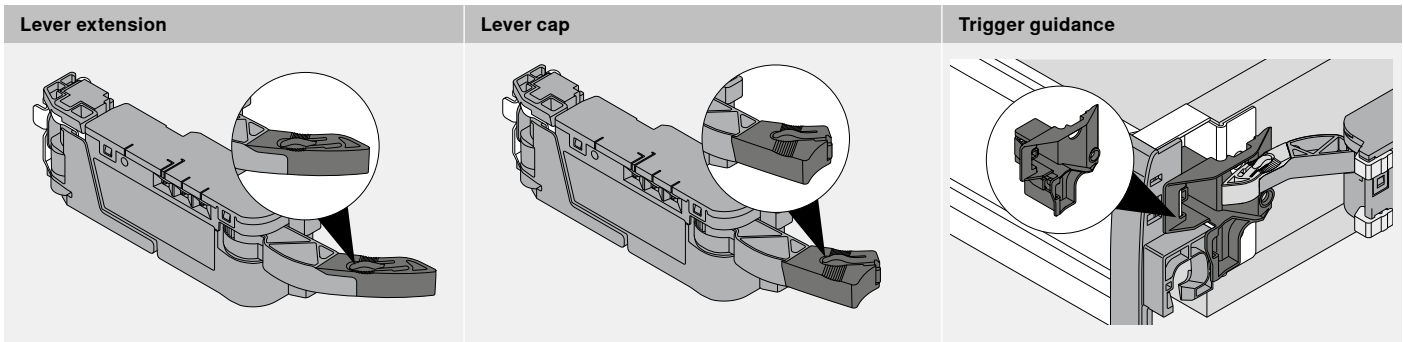

Cabinet base – drilling pattern		Front assembly – position – Blum distance bumper						
<p>Lower cabling</p> <p>131.5 96 Ø 10 BT = 8</p>	<p>Back cabling</p> <p>96 Ø 10 BT = 8</p>	<p>The Blum distance bumper ensures the required trigger path of 2 mm</p> <table border="1"> <tr> <th>Front height FH (mm)</th> <th>Blum distance bumper (pcs)</th> </tr> <tr> <td>Up to 300</td> <td>2</td> </tr> <tr> <td>From 301</td> <td>4</td> </tr> </table> <p>FA Front overlay FH Front height</p>	Front height FH (mm)	Blum distance bumper (pcs)	Up to 300	2	From 301	4
Front height FH (mm)	Blum distance bumper (pcs)							
Up to 300	2							
From 301	4							
<p>BT Drilling depth</p>	<p>BT Drilling depth</p>							
<p>Alternative drilling pattern – MINIPRESS top MINIPRESS</p>								

Standard cabinet – horizontal cross member

Cabinet	Position of drive unit
	$PL = LH - 10 \text{ mm}$ Round down to the nearest tenth LH Internal cabinet height PL Bracket profile length A Distance between bottom edge of cabinet profile and bottom edge of drive unit E Distance between bottom edge of cabinet top panel and fixing position of cabinet profile

Position – drive unit – box systems

Box system	Back	Back height	Internal cabinet width LW (mm)							
			242–266		267–286		287–316		≥ 317	
			A	E min.	A	E min.	A	E min.	A	E min.
LEGRABOX	Chipboard back	N	–	–	45	61	45	61	45	61
		M K C F	–	–	45	69	45	69	45	69
	Steel back	N	–	–	–	–	–	–	–	–
		M K C F	–	–	45	69	45	69	45	69
MERIVOBX	Chipboard back	N	–	–	28	32	28	32	28	32
		M K E F	–	–	45	54	45	54	45	54
	Steel back	N	–	–	–	–	–	–	–	–
		M K E F	–	–	45	54	45	54	45	54
TANDEMBOX	Chipboard back	N	35	56	35	56	35	56	28	49
		M K B C D	35	64	35	64	35	64	35	64
	Steel back	N	–	–	–	–	28	49	28	49
		M K B C D	–	–	35	64	35	64	35	64

A Distance between bottom edge of cabinet profile and bottom edge of drive unit
 E Distance between bottom edge of cabinet top panel and fixing position of cabinet profile
 – Not possible

Position – drive unit – runner systems

Runner system	Drawer height SKH (mm)	Internal cabinet width LW (mm)					
		224–234		235–428		≥ 429	
		A (mm)	E min. (mm)	A (mm)	E min. (mm)	A (mm)	E min. (mm)
MOVENTO	≥ 79	–	–	60	74	35	49
TANDEM	≥ 79	55	71	55	71	35	51

A Distance between bottom edge of cabinet profile and bottom edge of drive unit
 E Distance between bottom edge of cabinet top panel and fixing position of runner
 – Not possible

Standard cabinet – vertical cross member

Drilling distances – cabinet base cross member				
	Drawer back – box systems		X (mm)	T (mm)
	Chipboard back		NL + 19	NL + 34
	Steel back		NL + 2	NL + 17
	NL Nominal length			
	T Position front edge – cross member			
	X Drilling position			
Drawer back – runner systems		X (mm)	Y (mm)	
≥ 79		NL + 16	NL + 31	

Box system	Back	Back height	Internal cabinet width LW (mm)									
			242–266			267–286				287–316		
			Z (mm)	Lever extension	Trigger guidance	Z (mm)	Lever extension	Trigger guidance	Lever cap	Z (mm)	Lever extension	Trigger guidance
LEGRABOX	Chipboard back	N	–	–	–	184	●	–	–	184	●	–
		M K C F	–	–	–	184	●	–	–	184	●	–
	Steel back	N	–	–	–	–	–	–	–	–	–	–
		M K C F	–	–	–	184	✘	–	●	184	●	–
MERIVOBX	Chipboard back	N	–	–	–	174	✘	–	–	174	●	–
		M K E F	–	–	–	174	✘	–	–	174	●	–
	Steel back	N	–	–	–	–	–	–	–	–	–	–
		M K E F	–	–	–	174	●	–	–	174	●	–
TANDEMBOX	Chipboard back	N	179	✘	●	179	●	●	–	179	●	●
		M K B C D	179	✘	●	179	●	●	–	179	●	●
	Steel back	N	–	–	–	–	–	–	–	190	✘	–
		M K B C D	–	–	–	179	✘	–	–	179	●	–

Box system	Back	Back height	Internal cabinet width LW (mm)					
			317–386			≥ 387		
			Z (mm)	Lever extension	Trigger guidance	Z (mm)	Lever extension	Trigger guidance
LEGRABOX	Chipboard back	N	184	●	–	LW / 2	●	–
		M K C F	184	●	–	LW / 2	●	–
	Steel back	N	–	–	–	–	–	–
		M K C F	184	●	–	LW / 2	●	–
MERIVOBX	Chipboard back	N	174	●	–	LW / 2	●	–
		M K E F	174	●	–	LW / 2	●	–
	Steel back	N	–	–	–	–	–	–
		M K E F	174	●	–	LW / 2	●	–
TANDEMBOX	Chipboard back	N	179	●	○	LW / 2	●	○
		M K B C D	179	●	○	LW / 2	●	○
	Steel back	N	190	●	–	LW / 2	●	–
		M K B C D	179	●	–	LW / 2	●	–

LW Internal cabinet width	○ Not required
Z Dimension of engagement	– Not possible
● Required	✘ Remove

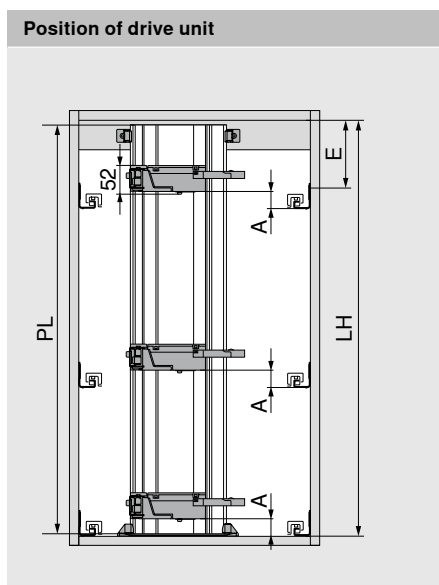
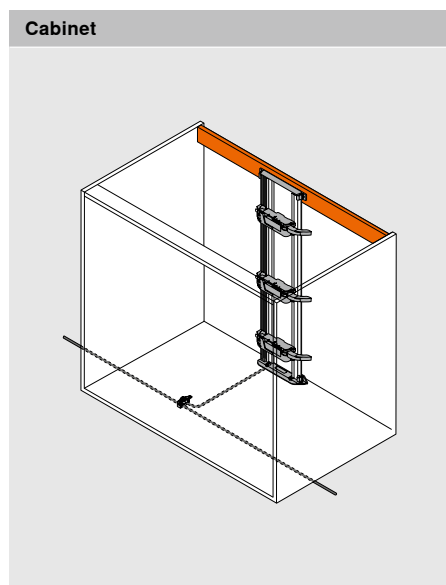
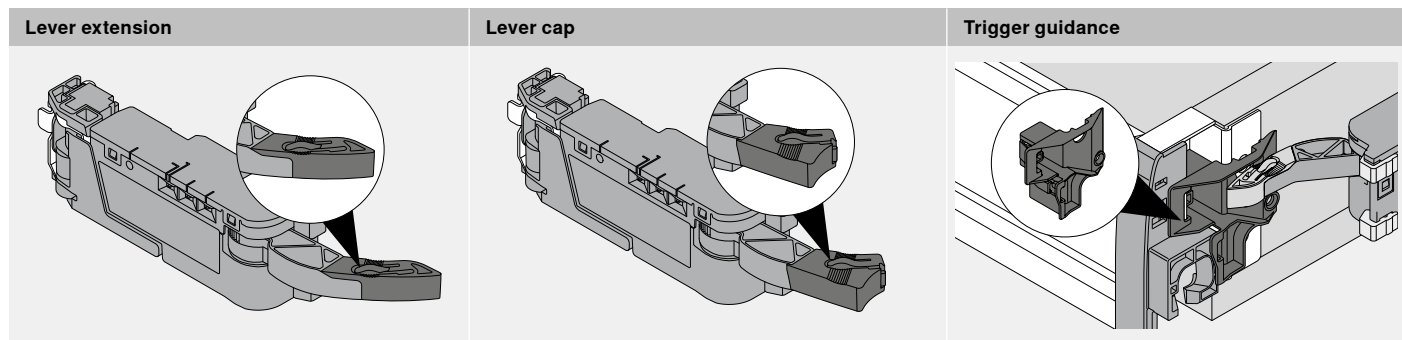
Standard cabinet – vertical cross member

$$PL = LH - 10 \text{ mm}$$

Round down to the nearest tenth

LH Internal cabinet height

PL Bracket profile length

A Distance between bottom edge of cabinet profile and bottom edge of drive unit

E Distance between bottom edge of cabinet top panel and fixing position of cabinet profile

Position – drive unit – box systems			Internal cabinet width LW (mm)							
Box system	Back	Back height	242–266		267–286		287–316		≥ 317	
			A	E min.	A	E min.	A	E min.	A	E min.
LEGRABOX	Chipboard back	N	–	–	45	61	45	61	45	61
		M K C F	–	–	45	69	45	69	45	69
	Steel back	N	–	–	–	–	–	–	–	–
		M K C F	–	–	45	69	45	69	45	69
MERIVOBX	Chipboard back	N	–	–	28	32	28	32	28	32
		M K E F	–	–	45	54	45	54	45	54
	Steel back	N	–	–	–	–	–	–	–	–
		M K E F	–	–	45	54	45	54	45	54
TANDEMBOX	Chipboard back	N	35	56	35	56	35	56	28	49
		M K B C D	35	64	35	64	35	64	35	64
	Steel back	N	–	–	–	–	28	49	28	49
		M K B C D	–	–	35	64	35	64	35	64

A Distance between bottom edge of cabinet profile and bottom edge of drive unit

E Distance between bottom edge of cabinet top panel and fixing position of cabinet profile

– Not possible

Standard cabinet – vertical cross member

Position – drive unit – runner systems		Internal cabinet width LW (mm)					
Runner system	Drawer height SKH (mm)	224–234		235–428		≥ 429	
		A (mm)	E min. (mm)	A (mm)	E min. (mm)	A (mm)	E min. (mm)
MOVENTO	≥ 79	–	–	60	84	35	54
TANDEM	≥ 79	55	81	55	81	35	61

A Distance between bottom edge of cabinet profile and bottom edge of drive unit
 E Distance between bottom edge of cabinet top panel and fixing position of runner
 – Not possible

Runner system	Drawer height SKH (mm)	Internal cabinet width LW (mm)							
		224–234		235–388		389–428		≥ 429	
		Z (mm)	Lever extension	Z (mm)	Lever extension	Z (mm)	Lever extension	Z (mm)	Lever extension
MOVENTO	≥ 79	–	–	164	●	164	●	LW / 2	●
TANDEM	≥ 79	164	–	164	●	LW / 2	●	LW / 2	●

LW Internal cabinet width
 Z Dimension of engagement
 ● Required
 – Not possible

Space requirement and safety distance – power supply unit housing

Base fixing

Back panel/wall fixing

Please note

Maintain a safety distance of 30 mm for air circulation. Otherwise there is a risk that the SERVO-DRIVE power supply unit could overheat. The dimensions in the drawing take the safety distance into account.

Front assembly – position – Blum distance bumper

The Blum distance bumper ensures the required trigger path of 2 mm

Front height FH (mm)	Blum distance bumper (pcs)
Up to 300	2
From 301	4

FA Front overlay
 FH Front height

Standard cabinet – vertical/horizontal cross member

Cabinet base – drilling pattern

Lower cabling

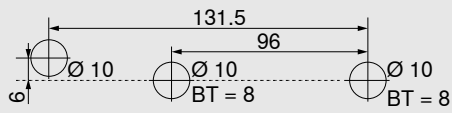
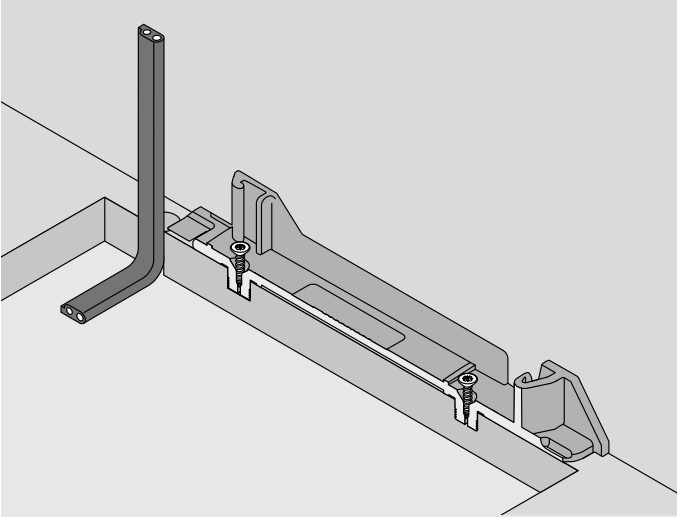

Back cabling

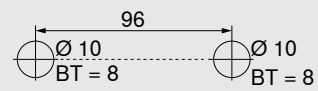
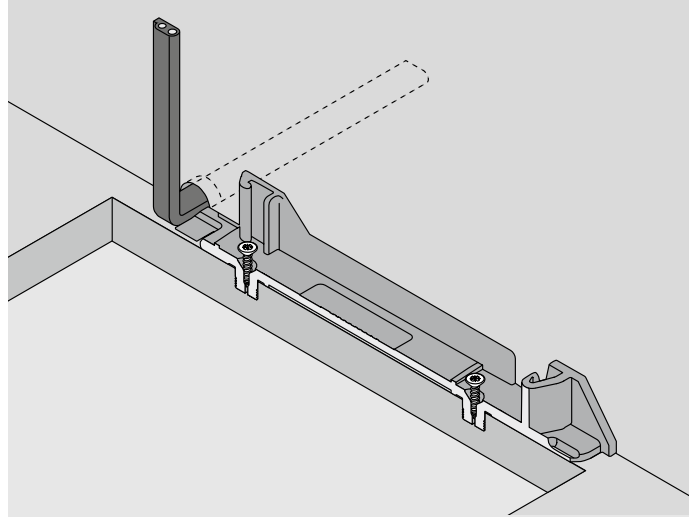

Alternative drilling pattern for MINIPRESS top and MINIPRESS

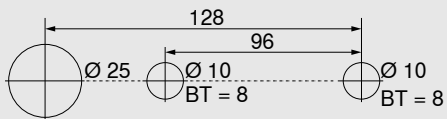

BT Drilling depth

Notes

SPACE TOWER



- Electrical motion support system in combination with BLUMOTION for soft and effortless closing
- With vertical bracket profile
- No fixed connection between the drive unit and pull-out
- Pull-outs need not be modified
- Tool-free drive unit assembly
- Simple cabling
- Shallow installation depth
- With inset pull-outs, SERVO-DRIVE for MERIVOBX is triggered by pulling the drawer

Space requirement

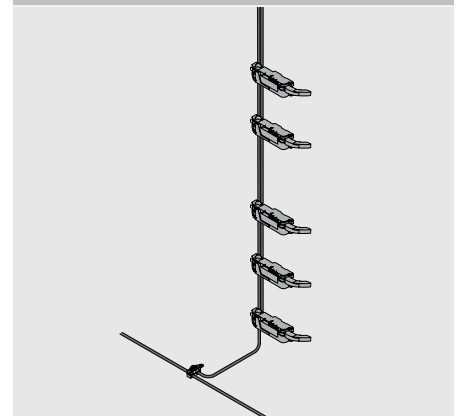

Ordering information

Bracket profile	
	Bracket profile with SERVO-DRIVE distribution cable
	Length (mm)
	650 Z10T650AA 750 Z10T750AA
	700 Z10T700AA 800 Z10T800AA
710 Z10T710AA	
	Bracket profile without SERVO-DRIVE distribution cable
	Length (mm)
	1170 Z10T1170A
Aluminium for cutting to size	
Cutting:	Internal cabinet height LH - 10 mm

Bracket profile attachment top/bottom		
	Horizontal cross member	
	Colour	Material
	TGR	K Z10D01E0.01

Alternative to 2

Bracket profile attachment bottom/back		
	Vertical cross member	
	Colour	Material
	TGR	K Z10D01EA.01

Connecting node and cable end protector		
	Colour	Material
	SZ	K Z10V100E.01
Consisting of:		
1x connecting node		
2x cable end protectors		

Drive unit			
	Colour	Material	
	TGR	K	Z10A3000.04
Incl. pre-mounted lever extension			

Lever cap for LEGRABOX			
	Colour	Material	
	SZ	K	Z10A3006
Steel back			
Required from height M and internal cabinet width LW of 267–286 mm			

Trigger guidance for TANDEMBOX			
	Colour	Material	
	R7037	K	Z10A3H00
Chipboard back			
Required for an LW of 242–316 mm			

SERVO-DRIVE distribution cable and cable end protector			
	Colour	Length (m)	
	SZ	8	Z10K800AE
Consisting of:			
1x SERVO-DRIVE distribution cable			
5x cable end protectors			
For cutting to size			
Can be used as distribution, bracket profile and communication cable			

SPACE TOWER

SERVO-DRIVE power supply unit incl. flex					
Markets	Language packages		Markets	Language packages	
E	A	Z10NE04EA	I	A	Z10NE04IA
E	B	Z10NE04EB	K	I	Z10NE04KI
E	C	Z10NE04EC	N	H	Z10NE04NH
E	D	Z10NE04ED	R	H	Z10NE04RH
E	E	Z10NE04EE	S	K	Z10NE04SK
E	F	Z10NE04EF	T	H	Z10NE04TH
E	I	Z10NE04EI	U	G	Z10NE04UG
B	A	Z10NE04BA	U	J	Z10NE04UJ
B	I	Z10NE04BI	Z	I	Z10NE04ZI
H	I	Z10NE04HI			
Incl. operating and installation instructions					
Consisting of:					
1 x	Power supply unit (output flex: length 2 m)				
1 x	Flex (1.5–1.8 m, incl. plug)				

Markets and language packages

Code		Language packages*	
Markets		Language packages*	
E	Europe	A	DE, EN, FR, IT, NL
B	GB	B	DA, EN, FI, NO, SV
H	IN	C	EL, EN, HR, SR, SL, TR
I	IL	D	EN, ES, FR, IT, PT
K	AU	E	CS, HU, PL, SK
N	CN	F	BG, ET, LV, LT, RO, RU, GB
R	KR	G	EN, ES, FR
S	BR	H	EN, ZH, KO
T	TW	I	EN
U	US CA JP	J	JA
Z	ZA	K	EN, ES, PT

* Language code according to the ISO 639 standard

Power supply unit housing			
	Base fixing		
	Colour	Material	
	TGR	K	Z10NG000
Incl. cover			
For SERVO-DRIVE power supply unit			

Alternative

Power supply unit housing			
	Back panel/wall fixing		
	Colour	Material	
	TGR	K	Z10NG120
For SERVO-DRIVE power supply unit			

Accessories

Cable holder			
	Colour	Material	
	WS	K	Z10K0009
E.g. for fixing the SERVO-DRIVE distribution cable			

Front/base stabiliser			
	Colour	Material	
	R7037	K	Z96.10E1

Synchronisation cable			
	Length (mm)		
	80		Z10K008S
	500		Z10K050S
	1200		Z10K120S
	1600		Z10K160S
Connects two drive units that need to open simultaneously			

Top bracket profile

Planning

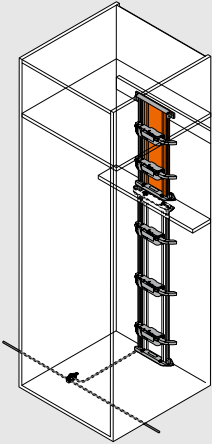
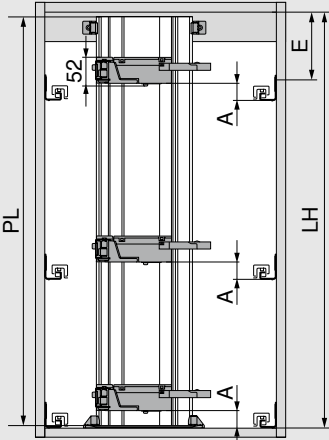
Cabinet	Position of drive unit
	
	<p>PL = LH - 10 mm</p> <p>Round down to the nearest tenth</p> <p>LH Internal cabinet height</p> <p>PL Bracket profile length</p> <p>A Distance between bottom edge of cabinet profile and bottom edge of drive unit</p> <p>E Distance between bottom edge of cabinet top panel and fixing position of cabinet profile</p>

Position – drive unit – box systems										
Box system	Back	Back height	Internal cabinet width LW (mm)							
			242–266		267–286		287–316		≥ 317	
			A	E min.	A	E min.	A	E min.	A	E min.
LEGRABOX	Chipboard back	N	–	–	45	61	45	61	45	61
		M K C F	–	–	45	69	45	69	45	69
	Steel back	N	–	–	–	–	–	–	–	–
		M K C F	–	–	45	69	45	69	45	69
MERIVOBX	Chipboard back	N	–	–	28	32	28	32	28	32
		M K E F	–	–	45	54	45	54	45	54
	Steel back	N	–	–	–	–	–	–	–	–
		M K E F	–	–	45	54	45	54	45	54
TANDEMBOX	Chipboard back	N	35	56	35	56	35	56	28	49
		M K B C D	35	64	35	64	35	64	35	64
	Steel back	N	–	–	–	–	28	49	28	49
		M K B C D	–	–	35	64	35	64	35	64
<p>A Distance between bottom edge of cabinet profile and bottom edge of drive unit</p> <p>E Distance between bottom edge of cabinet top panel and fixing position of cabinet profile</p> <p>– Not possible</p>										

Position – drive unit – runner systems							
Runner system	Drawer height SKH (mm)	Internal cabinet width LW (mm)					
		224–234		235–428		≥ 429	
		A (mm)	E min. (mm)	A (mm)	E min. (mm)	A (mm)	E min. (mm)
MOVENTO	≥ 79	–	–	60	74	35	49
TANDEM	≥ 79	55	71	55	71	35	51
<p>A Distance between bottom edge of cabinet profile and bottom edge of drive unit</p> <p>E Distance between bottom edge of cabinet top panel and fixing position of runner</p> <p>– Not possible</p>							

Top bracket profile

Drilling distances – cabinet base cross member				
	Drawer back – box systems		X (mm)	T (mm)
	Chipboard back		NL + 19	NL + 34
	Steel back		NL + 2	NL + 17
	NL Nominal length			
	T Position front edge – cross member			
	X Drilling position			
Drawer back – runner systems		X (mm)	Y (mm)	
≥ 79		NL + 16	NL + 31	

Box system	Back	Back height	Internal cabinet width LW (mm)									
			242–266			267–286				287–316		
			Z (mm)	Lever extension	Trigger guidance	Z (mm)	Lever extension	Trigger guidance	Lever cap	Z (mm)	Lever extension	Trigger guidance
LEGRABOX	Chipboard back	N	–	–	–	184	●	–	–	184	●	–
		M K C F	–	–	–	184	●	–	–	184	●	–
	Steel back	N	–	–	–	–	–	–	–	–	–	–
		M K C F	–	–	–	184	✘	–	●	184	●	–
MERIVOBX	Chipboard back	N	–	–	–	174	✘	–	–	174	●	–
		M K E F	–	–	–	174	✘	–	–	174	●	–
	Steel back	N	–	–	–	–	–	–	–	–	–	–
		M K E F	–	–	–	174	●	–	–	174	●	–
TANDEMBOX	Chipboard back	N	179	✘	●	179	●	●	–	179	●	●
		M K B C D	179	✘	●	179	●	●	–	179	●	●
	Steel back	N	–	–	–	–	–	–	–	190	✘	–
		M K B C D	–	–	–	179	✘	–	–	179	●	–

Box system	Back	Back height	Internal cabinet width LW (mm)					
			317–386			≥ 387		
			Z (mm)	Lever extension	Trigger guidance	Z (mm)	Lever extension	Trigger guidance
LEGRABOX	Chipboard back	N	184	●	–	LW / 2	●	–
		M K C F	184	●	–	LW / 2	●	–
	Steel back	N	–	–	–	–	–	–
		M K C F	184	●	–	LW / 2	●	–
MERIVOBX	Chipboard back	N	174	●	–	LW / 2	●	–
		M K E F	174	●	–	LW / 2	●	–
	Steel back	N	–	–	–	–	–	–
		M K E F	174	●	–	LW / 2	●	–
TANDEMBOX	Chipboard back	N	179	●	○	LW / 2	●	○
		M K B C D	179	●	○	LW / 2	●	○
	Steel back	N	190	●	–	LW / 2	●	–
		M K B C D	179	●	–	LW / 2	●	–

LW Internal cabinet width	○ Not required
Z Dimension of engagement	– Not possible
● Required	✘ Remove

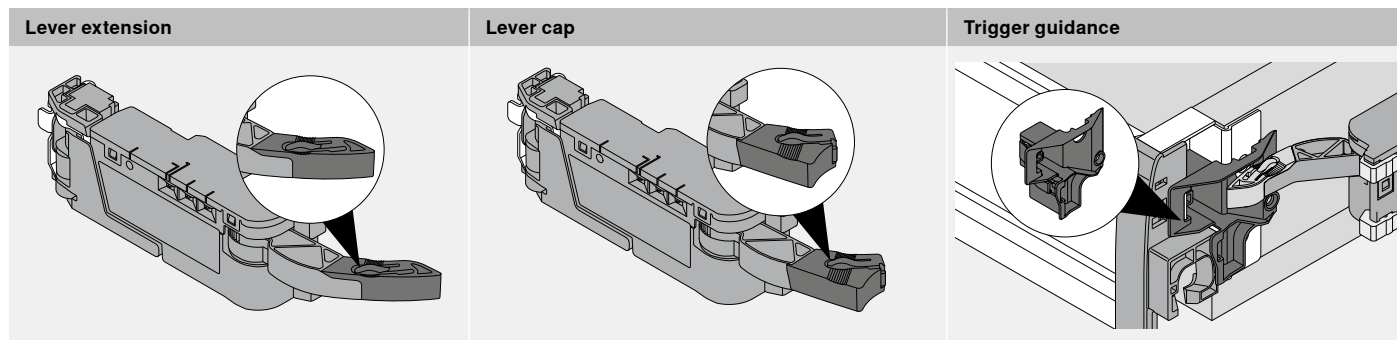
Top bracket profile

Runner system	Drawer height SKH (mm)	Internal cabinet width LW (mm)							
		224–234		235–388		389–428		≥ 429	
		Z (mm)	Lever extension	Z (mm)	Lever extension	Z (mm)	Lever extension	Z (mm)	Lever extension
MOVENTO	≥ 79	–	–	164	●	164	●	LW / 2	●
TANDEM	≥ 79	164	–	164	●	LW / 2	●	LW / 2	●

LW Internal cabinet width
 Z Dimension of engagement
 ● Required
 – Not possible

Space requirement and safety distance – power supply unit housing

Base fixing

Back panel/wall fixing

Please note

Maintain a safety distance of 30 mm for air circulation. Otherwise there is a risk that the SERVO-DRIVE power supply unit could overheat. The dimensions in the drawing take the safety distance into account.

Front assembly – position – Blum distance bumper

The Blum distance bumper ensures the required trigger path of 2 mm

Front height FH (mm)	Blum distance bumper (pcs)
Up to 300	2
From 301	4

FA Front overlay
 FH Front height

Bottom bracket profile

Cabinet	Position of drive unit
	<p>$PL = LH - 10 \text{ mm}$</p> <p>Round down to the nearest tenth</p> <p>LH Internal cabinet height</p> <p>PL Bracket profile length</p> <p>A Distance between bottom edge of cabinet profile and bottom edge of drive unit</p> <p>E Distance between bottom edge of cabinet top panel and fixing position of cabinet profile</p>

Position – drive unit – box systems										
Box system	Back	Back height	Internal cabinet width LW (mm)							
			242–266		267–286		287–316		≥ 317	
			A	E min.	A	E min.	A	E min.	A	E min.
LEGRABOX	Chipboard back	N	–	–	45	61	45	61	45	61
		M K C F	–	–	45	69	45	69	45	69
	Steel back	N	–	–	–	–	–	–	–	–
		M K C F	–	–	45	69	45	69	45	69
MERIVOBX	Chipboard back	N	–	–	28	32	28	32	28	32
		M K E F	–	–	45	54	45	54	45	54
	Steel back	N	–	–	–	–	–	–	–	–
		M K E F	–	–	45	54	45	54	45	54
TANDEMBOX	Chipboard back	N	35	56	35	56	35	56	28	49
		M K B C D	35	64	35	64	35	64	35	64
	Steel back	N	–	–	–	–	28	49	28	49
		M K B C D	–	–	35	64	35	64	35	64
<p>A Distance between bottom edge of cabinet profile and bottom edge of drive unit</p> <p>E Distance between bottom edge of cabinet top panel and fixing position of cabinet profile</p> <p>– Not possible</p>										

Position – drive unit – runner systems							
Runner system	Drawer height SKH (mm)	Internal cabinet width LW (mm)					
		224–234		235–428		≥ 429	
		A (mm)	E min. (mm)	A (mm)	E min. (mm)	A (mm)	E min. (mm)
MOVENTO	≥ 79	–	–	60	74	35	49
TANDEM	≥ 79	55	71	55	71	35	51
<p>A Distance between bottom edge of cabinet profile and bottom edge of drive unit</p> <p>E Distance between bottom edge of cabinet top panel and fixing position of runner</p> <p>– Not possible</p>							

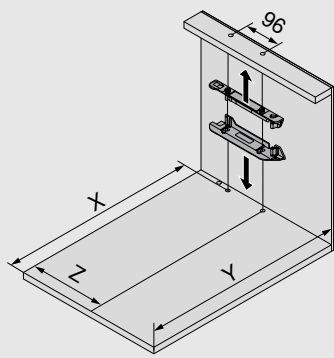
Bottom bracket profile
Drilling distances – cabinet base | cross member

Drawer back – box systems	X (mm)	Y (mm)
Chipboard back	NL + 19	NL + 33
Steel back	NL + 2	NL + 16

NL Nominal length

X Drilling position

Y Min. space requirement

Z Dimension of engagement

Drawer back – runner systems	X (mm)	Y (mm)
≥ 79	NL + 16	NL + 30

Box system	Back	Back height	Internal cabinet width LW (mm)									
			242–266			267–286				287–316		
			Z (mm)	Lever extension	Trigger guidance	Z (mm)	Lever extension	Trigger guidance	Lever cap	Z (mm)	Lever extension	Trigger guidance
LEGRABOX	Chipboard back	N	–	–	–	184	●	–	–	184	●	–
		M K C F	–	–	–	184	●	–	–	184	●	–
	Steel back	N	–	–	–	–	–	–	–	–	–	–
		M K C F	–	–	–	184	✘	–	●	184	●	–
MERIVOBX	Chipboard back	N	–	–	–	174	✘	–	–	174	●	–
		M K E F	–	–	–	174	✘	–	–	174	●	–
	Steel back	N	–	–	–	–	–	–	–	–	–	–
		M K E F	–	–	–	174	●	–	–	174	●	–
TANDEMBOX	Chipboard back	N	179	✘	●	179	●	●	–	179	●	●
		M K B C D	179	✘	●	179	●	●	–	179	●	●
	Steel back	N	–	–	–	–	–	–	–	190	✘	–
		M K B C D	–	–	–	179	✘	–	–	179	●	–

Box system	Back	Back height	Internal cabinet width LW (mm)					
			317–386			≥ 387		
			Z (mm)	Lever extension	Trigger guidance	Z (mm)	Lever extension	Trigger guidance
LEGRABOX	Chipboard back	N	184	●	–	LW / 2	●	–
		M K C F	184	●	–	LW / 2	●	–
	Steel back	N	–	–	–	–	–	–
		M K C F	184	●	–	LW / 2	●	–
MERIVOBX	Chipboard back	N	174	●	–	LW / 2	●	–
		M K E F	174	●	–	LW / 2	●	–
	Steel back	N	–	–	–	–	–	–
		M K E F	174	●	–	LW / 2	●	–
TANDEMBOX	Chipboard back	N	179	●	○	LW / 2	●	○
		M K B C D	179	●	○	LW / 2	●	○
	Steel back	N	190	●	–	LW / 2	●	–
		M K B C D	179	●	–	LW / 2	●	–

LW Internal cabinet width

○ Not required

Z Dimension of engagement

– Not possible

● Required

✘ Remove

Bottom bracket profile

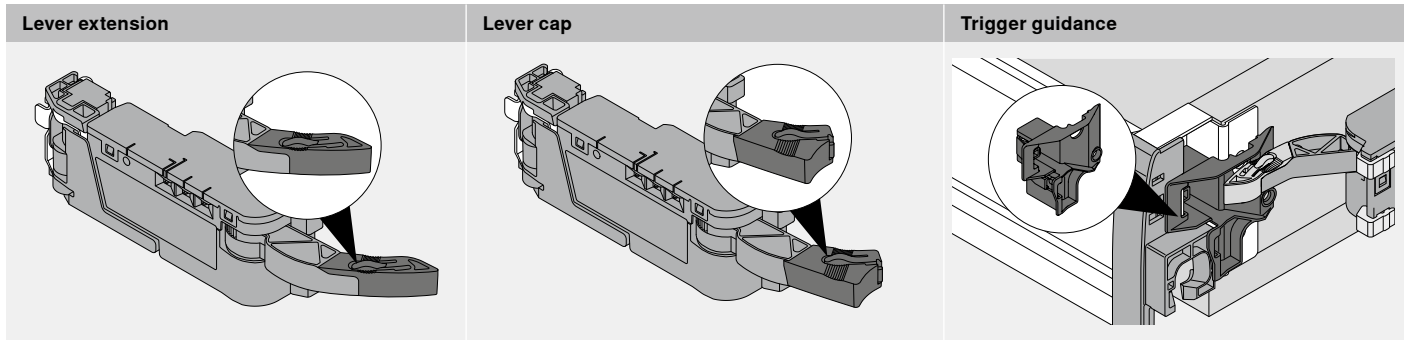

Runner system	Drawer height SKH (mm)	Internal cabinet width LW (mm)							
		224–234		235–388		389–428		≥ 429	
		Z (mm)	Lever extension	Z (mm)	Lever extension	Z (mm)	Lever extension	Z (mm)	Lever extension
MOVENTO	≥ 79	–	–	164	●	164	●	LW / 2	●
TANDEM	≥ 79	164	–	164	●	LW / 2	●	LW / 2	●

LW Internal cabinet width
 Z Dimension of engagement
 ● Required
 – Not possible

Space requirement and safety distance – power supply unit housing

Base fixing

Back panel/wall fixing

Please note

Maintain a safety distance of 30 mm for air circulation. Otherwise there is a risk that the SERVO-DRIVE power supply unit could overheat. The dimensions in the drawing take the safety distance into account.

Front assembly – position – Blum distance bumper

The Blum distance bumper ensures the required trigger path of 2 mm

Front height FH (mm)	Blum distance bumper (pcs)
Up to 300	2
From 301	4

FA Front overlay
 FH Front height

Sink cabinet



- Electrical motion support system in combination with BLUMOTION for soft and effortless closing
- With attachment bracket
- No fixed connection between the drive unit and pull-out
- Pull-outs need not be modified
- Quick installation of pre-assembled parts

Space requirement

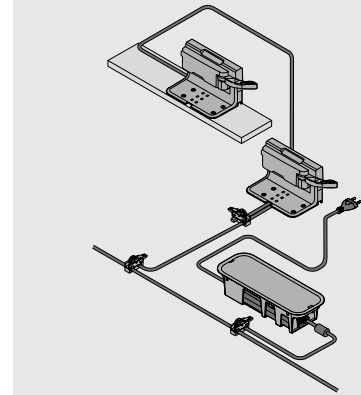

Ordering information

Blum distance bumper			
	Ø (mm)	Colour	
	5	TGR	993.0530
	8	TGR	993.0830.01
Up to front height 300 mm, use 2 pcs			
From front height 300 mm, use 4 pcs			
For LEGRABOX/MERIVOBX 70 kg cabinet profile, use 4 pcs			
For TANDEMBOX 65 kg cabinet profile, use 4 pcs			

Attachment bracket 1 tier			
	Colour	Material	
	TGR	K	Z10D0311

Drive unit			
	Colour	Material	
	TGR	K	Z10A3000.04
Incl. pre-mounted lever extension			

Drip protection feature for attachment bracket 1 tier			
	Colour	Material	
	TGR	K	Z10D0316

SERVO-DRIVE distribution cable and cable end protector			
	Colour	Length (m)	
	SZ	8	Z10K800AE
Consisting of:			
1x SERVO-DRIVE distribution cable			
5x cable end protectors			
For cutting to size			
Can be used as distribution, bracket profile and communication cable			

Connecting node and cable end protector			
	Colour	Material	
	SZ	K	Z10V100E.01
Consisting of:			
1x connecting node			
2x cable end protectors			

Sink cabinet

SERVO-DRIVE power supply unit incl. flex					
Markets	Language packages		Markets	Language packages	
E	A	Z10NE04EA	I	A	Z10NE04IA
E	B	Z10NE04EB	K	I	Z10NE04KI
E	C	Z10NE04EC	N	H	Z10NE04NH
E	D	Z10NE04ED	R	H	Z10NE04RH
E	E	Z10NE04EE	S	K	Z10NE04SK
E	F	Z10NE04EF	T	H	Z10NE04TH
E	I	Z10NE04EI	U	G	Z10NE04UG
B	A	Z10NE04BA	U	J	Z10NE04UJ
B	I	Z10NE04BI	Z	I	Z10NE04ZI
H	I	Z10NE04HI			
Incl. operating and installation instructions					
Consisting of:					
1 x	Power supply unit (output flex: length 2 m)				
1 x	Flex (1.5–1.8 m, incl. plug)				

Markets and language packages

Code		
Markets	Language packages*	
E Europe	A	DE, EN, FR, IT, NL
B GB	B	DA, EN, FI, NO, SV
H IN	C	EL, EN, HR, SR, SL, TR
I IL	D	EN, ES, FR, IT, PT
K AU	E	CS, HU, PL, SK
N CN	F	BG, ET, LV, LT, RO, RU, UK
R KR	G	EN, ES, FR
S BR	H	EN, ZH, KO
T TW	I	EN
U US CA JP	J	JA
Z ZA	K	EN, ES, PT

* Language code according to the ISO 639 standard

Power supply unit housing			
	Base fixing		
	Colour	Material	
	TGR	K	Z10NG000
Incl. cover			
For SERVO-DRIVE power supply unit			

Alternative

Power supply unit housing			
	Back panel/wall fixing		
	Colour	Material	
	TGR	K	Z10NG120
For SERVO-DRIVE power supply unit			

Accessories

Cable holder			
	Colour	Material	
	WS	K	Z10K0009
E.g. for fixing the SERVO-DRIVE distribution cable			

Front/base stabiliser			
	Colour	Material	
	R7037	K	Z96.10E1

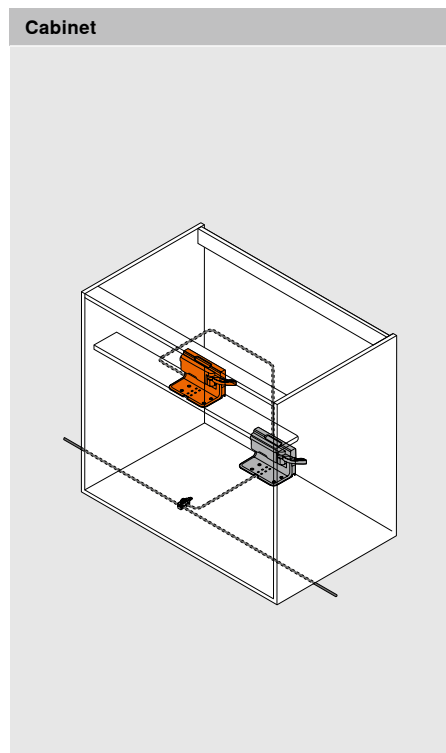
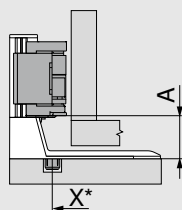
Cross member – attachment bracket 1 tier

Cross member – attachment bracket 1 tier

- X Drilling position
- A Distance between bottom edge of attachment bracket and bottom edge of drive unit
- * Measured from cabinet front edge

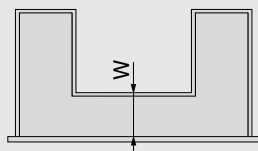
Box system	Back	Back height	A (mm)
LEGRABOX	Centre piece	N M K C F	45
MERIVOBX	Centre piece	N	28
		M K E F	45
TANDEMBOX	Centre piece	N	28
		M K B C D	35
Runner system	Drawer height SKH (mm)	A (mm)	
MOVENTO	≥ 79	35	
TANDEM	≥ 79	35	

Recommendation

W Distance between front edge of drawer base and centre piece

W = NL outer drawer side - NL inner drawer side

LEGRABOX: min. 150 mm

MERIVOBX: min. 150 mm

TANDEMBOX: min. 100 mm

Runner systems: min. 100 mm

NL Nominal length

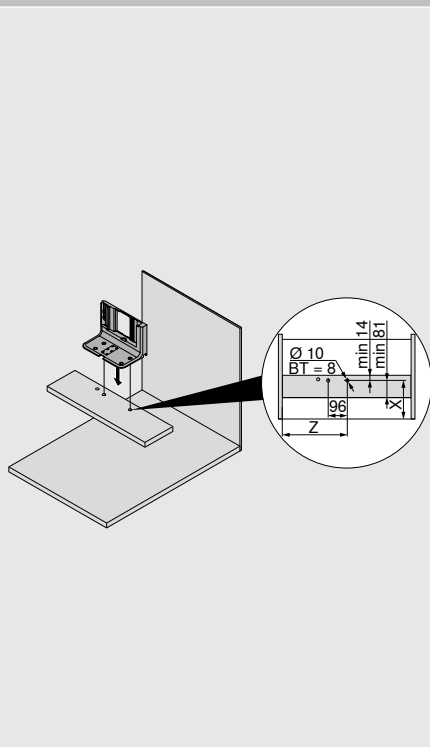
Cross member – attachment bracket 1 tier

Box system	Back	Back height	Internal cabinet width LW (mm)	
			≥ 387	
			External nominal length NL (mm)	
			450–650*	
			X (mm)	Z (mm)
LEGRABOX	Centre piece	N M K C F	W + 27	LW / 2
MERIVOBX	Centre piece	N M K E F	W + 27	LW / 2
TANDEMBOX	Centre piece	N M K B C D	W + 27	LW / 2
Runner system	Drawer height SKH (mm)	Internal cabinet width LW (mm)		
		≥ 429		
		X (mm)	Z (mm)	
MOVENTO	≥ 79	W + 24	LW / 2	
TANDEM	≥ 79	W + 24	LW / 2	

BT Drilling depth

X Drilling position

Z Dimension of engagement

Cabinet base – attachment bracket 1 tier

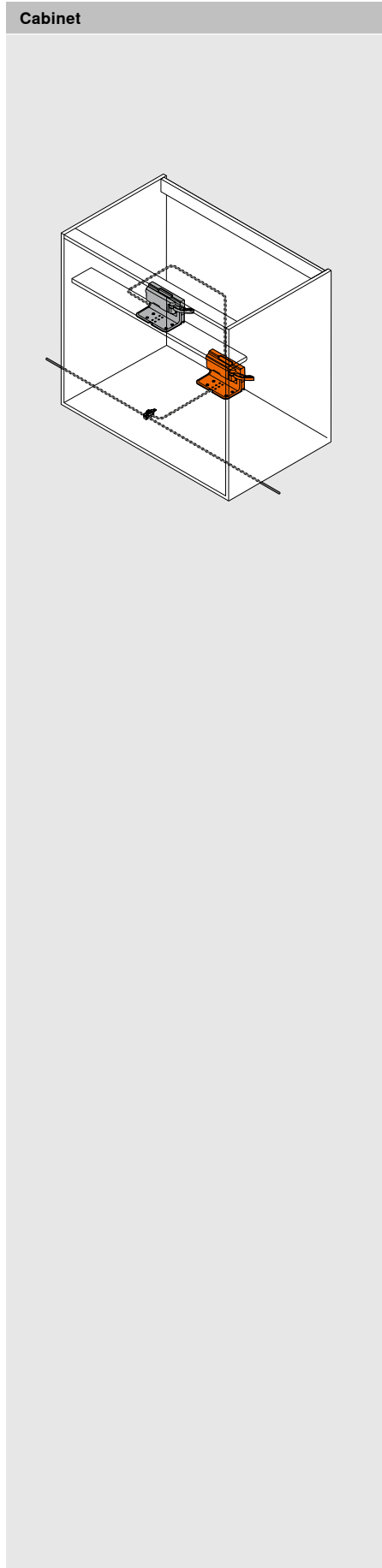

Cabinet base – attachment bracket 1 tier – box systems

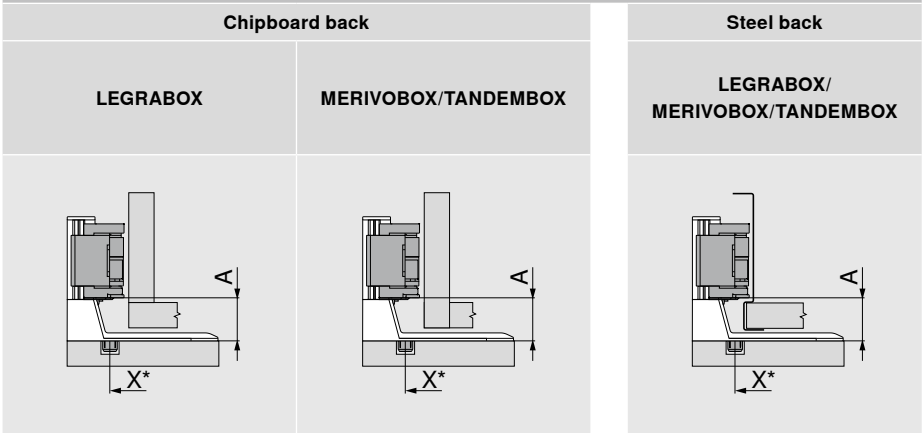

X Drilling position
 A Distance between bottom edge of attachment bracket and bottom edge of drive unit
 * Measured from cabinet front edge

Box system	Back	Back height	LW (mm)
			≥ 387
			A (mm)
LEGRABOX	Chipboard back	N M K C F	45
	Steel back	N	–
MERIVOBOX	Chipboard back	N	28
	Steel back	M K E F	45
TANDEMBOX	Chipboard back	N	28
	Steel back	M K B C D	35

LW Internal cabinet width

Cabinet base – attachment bracket 1 tier – runner systems

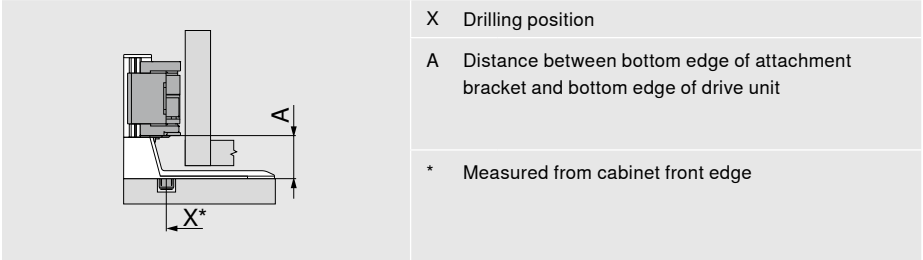

Runner system	Drawer height SKH (mm)	Internal cabinet width LW (mm)
		≥ 429
		A (mm)
MOVENTO	≥ 79	35
TANDEM	≥ 79	35

Cabinet base – attachment bracket 1 tier

Cabinet base – attachment bracket 1 tier					
	Back		X (mm)	Y (mm)	Z (mm)
	Chipboard back	LEGRABOX MERIVOBOX TANDEMBOX	NL + 19	NL + 35	LW / 2
		MERIVOBOX – cabinet profile with over extension	NL - 31	NL + 3	LW / 2
	Steel back	LEGRABOX MERIVOBOX TANDEMBOX	NL + 2	NL + 18	LW / 2
		MERIVOBOX – cabinet profile with over extension	NL - 48	NL + 3	LW / 2
	Drawer height SKH (mm)		X (mm)	Y (mm)	Z (mm)
≥ 79		NL + 16	NL + 30	LW / 2	
LW Internal cabinet width					
NL Nominal length					
X Drilling position					
Y Min. space requirement					
Z Dimension of engagement					

Space requirement and safety distance – power supply unit housing		
		<p>Please note</p> <p>Maintain a safety distance of 30 mm for air circulation. Otherwise there is a risk that the SERVO-DRIVE power supply unit could overheat. The dimensions in the drawing take the safety distance into account.</p>
Base fixing	Back panel/wall fixing	

Front assembly – position – Blum distance bumper							
	<p>The Blum distance bumper ensures the required trigger path of 2 mm</p> <table border="1"> <thead> <tr> <th>Front height FH (mm)</th> <th>Blum distance bumper (pcs)</th> </tr> </thead> <tbody> <tr> <td>Up to 300</td> <td>2</td> </tr> <tr> <td>From 301</td> <td>4</td> </tr> </tbody> </table> <p>FA Front overlay FH Front height</p>	Front height FH (mm)	Blum distance bumper (pcs)	Up to 300	2	From 301	4
Front height FH (mm)	Blum distance bumper (pcs)						
Up to 300	2						
From 301	4						

Cabinet base – attachment bracket 1 tier

Cabinet base – drilling pattern

Lower cabling

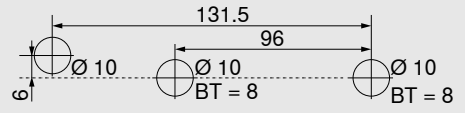
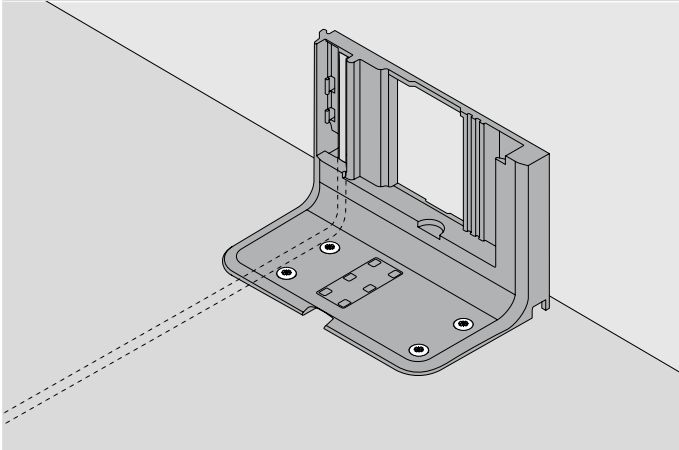

Alternative drilling pattern for MINIPRESS top and MINIPRESS

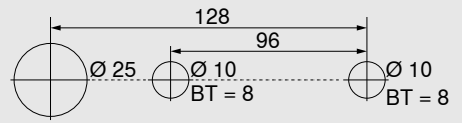

BT Drilling depth

Cabinet with single pull-out – horizontal bracket profile



- Electrical motion support system in combination with BLUMOTION for soft and effortless closing
- With horizontal bracket profile
- No fixed connection between the drive unit and pull-out
- Pull-outs need not be modified
- Quick installation of pre-assembled parts

Space requirement

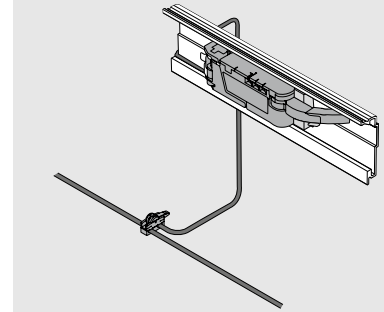

Ordering information

Blum distance bumper			
	Ø (mm)	Colour	
	5	TGR	993.0530
	8	TGR	993.0830.01
Up to front height 300 mm, use 2 pcs			
From front height 300 mm, use 4 pcs			
For LEGRABOX/MERIVOBX 70 kg cabinet profile, use 4 pcs			
For TANDEMBOX 65 kg cabinet profile, use 4 pcs			

Horizontal bracket profile			
	Length (mm)	Material	
	1143	Alu	Z10T1143B
For cabinet width KB 275–1200 mm			
Cutting:	Internal cabinet width LW – 19 mm		

Horizontal bracket profile attachment			
	Colour	Material	
	TGR	K	Z10D5210
Consisting of:			
1x bracket profile attachment left/right			
1x bracket profile adapter for drive unit			
Chipboard screws and system screws can be used			

Drive unit			
	Colour	Material	
	TGR	K	Z10A3000.04
Incl. pre-mounted lever extension			

Lever cap for LEGRABOX			
	Colour	Material	
	SZ	K	Z10A3006
Steel back			
Required from height M and internal cabinet width LW of 267–286 mm			

Trigger guidance for TANDEMBOX			
	Colour	Material	
	R7037	K	Z10A3H00
Chipboard back			
Required for an LW of 242–316 mm			

SERVO-DRIVE distribution cable and cable end protector			
	Colour	Length (m)	
	SZ	8	Z10K800AE
Consisting of:			
1x SERVO-DRIVE distribution cable			
5x cable end protectors			
For cutting to size			
Can be used as distribution, bracket profile and communication cable			

Cabinet with single pull-out – horizontal bracket profile

	Connecting node and cable end protector		
	Colour	Material	
	SZ	K	Z10V100E.01
Consisting of:			
1x connecting node			
2x cable end protectors			

SERVO-DRIVE power supply unit incl. flex					
Markets	Language packages		Markets	Language packages	
E	A	Z10NE04EA	I	A	Z10NE04IA
E	B	Z10NE04EB	K	I	Z10NE04KI
E	C	Z10NE04EC	N	H	Z10NE04NH
E	D	Z10NE04ED	R	H	Z10NE04RH
E	E	Z10NE04EE	S	K	Z10NE04SK
E	F	Z10NE04EF	T	H	Z10NE04TH
E	I	Z10NE04EI	U	G	Z10NE04UG
B	A	Z10NE04BA	U	J	Z10NE04UJ
B	I	Z10NE04BI	Z	I	Z10NE04ZI
H	I	Z10NE04HI			
Incl. operating and installation instructions					
Consisting of:					
	1 x	Power supply unit (output flex: length 2 m)			
	1 x	Flex (1.5–1.8 m, incl. plug)			

Markets and language packages

Code			
Markets		Language packages*	
E	Europe	A	DE, EN, FR, IT, NL
B	GB	B	DA, EN, FI, NO, SV
H	IN	C	EL, EN, HR, SR, SL, TR
I	IL	D	EN, ES, FR, IT, PT
K	AU	E	CS, HU, PL, SK
N	CN	F	BG, ET, LV, LT, RO, RU, GB
R	KR	G	EN, ES, FR
S	BR	H	EN, ZH, KO
T	TW	I	EN
U	US CA JP	J	JA
Z	ZA	K	EN, ES, PT

* Language code according to the ISO 639 standard

Power supply unit housing			
	Base fixing		
	Colour	Material	
	TGR	K	Z10NG000
Incl. cover			
For SERVO-DRIVE power supply unit			

Alternative

Power supply unit housing			
	Back panel/wall fixing		
	Colour	Material	
	WGR	K	Z10NG120
For SERVO-DRIVE power supply unit			

Accessories

Cable holder			
	Colour	Material	
	WS	K	Z10K0009
E.g. for fixing the SERVO-DRIVE distribution cable			

Front/base stabiliser			
	Colour	Material	
	R7037	K	Z96.10E1

Cabinet with single pull-out – horizontal bracket profile

Planning

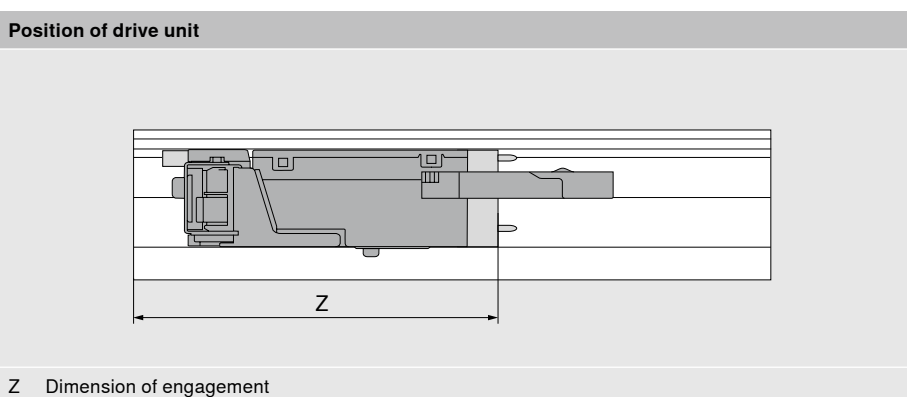
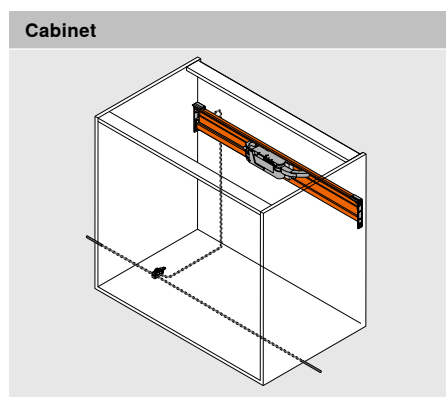

Box system	Back	Back height	Internal cabinet width LW (mm)										
			242–266			267–286				287–316			
			Z (mm)	Lever extension	Trigger guidance	Z (mm)	Lever extension	Trigger guidance	Lever cap	Z (mm)	Lever extension	Trigger guidance	
LEGRABOX	Chipboard back	N	–	–	–	–	–	–	–	–	193	×	–
		M K C F	–	–	–	182	●	–	○	182	●	–	
	Steel back	N	–	–	–	–	–	–	–	–	–	–	–
		M K C F	–	–	–	182	●	–	○	182	●	–	
MERIVOBX	Chipboard back	N	–	–	–	177	×	–	–	177	●	–	
		M K E F	–	–	–	177	×	–	–	177	●	–	
	Steel back	N	–	–	–	–	–	–	–	–	–	–	
		M K E F	–	–	–	177	●	–	–	177	●	–	
TANDEMBOX	Chipboard back	N	–	–	–	–	–	–	–	193	×	○	
		M K B C D	182	×	●	182	×	●	○	182	●	●	
	Steel back	N	–	–	–	193	×	○	○	193	●	○	
		M K B C D	–	–	–	182	×	○	○	182	●	○	

Box system	Back	Back height	Internal cabinet width LW (mm)					
			317–386			≥ 387		
			Z (mm)	Lever extension	Trigger guidance	Z (mm)	Lever extension	Trigger guidance
LEGRABOX	Chipboard back	N	193	●	–	LW / 2	●	–
		M K C F	182	●	–	LW / 2	●	–
	Steel back	N	–	–	–	–	–	–
		M K C F	182	●	–	LW / 2	●	–
MERIVOBX	Chipboard back	N	177	●	–	LW / 2	●	–
		M K E F	177	●	–	LW / 2	●	–
	Steel back	N	–	–	–	–	–	–
		M K E F	177	●	–	LW / 2	●	–
TANDEMBOX	Chipboard back	N	193	●	○	LW / 2	●	○
		M K B C D	182	●	○	LW / 2	●	○
	Steel back	N	193	●	○	LW / 2	●	○
		M K B C D	182	●	○	LW / 2	●	○

LW Internal cabinet width

○ Not required

Z Dimension of engagement

– Not possible

● Required

× Remove

Cabinet with single pull-out – horizontal bracket profile

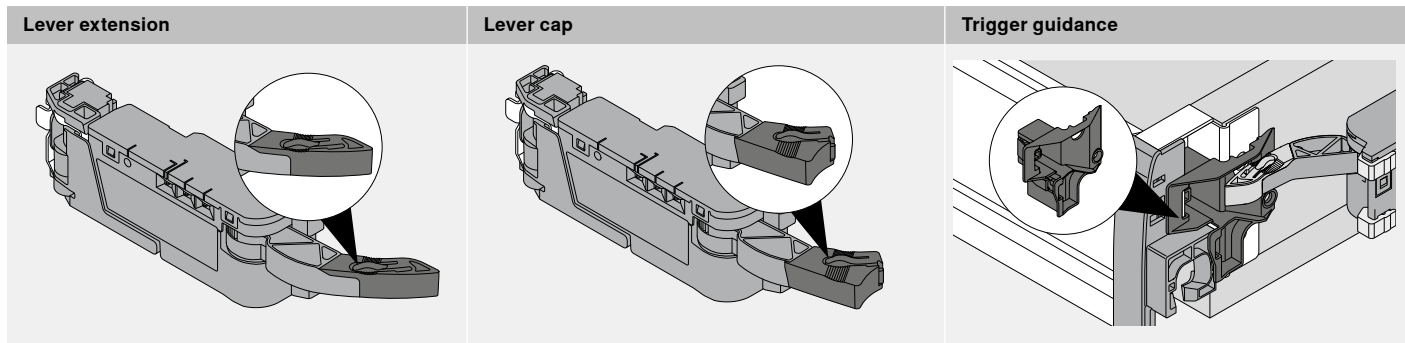

Drilling distances				
LEGRABOX		Back	X (mm)	Y (mm)
		Chipboard back	NL - 9	NL + 37
		Steel back	NL - 26	NL + 20
		NL Nominal length		
		X Drilling position		
		Y Min. space requirement		
MERIVOBX				
		* 32 mm for back height N		
		** 45 mm for back height N		
TANDEMBOX				
		* 55 mm for back height N		
		** 24 mm for back height N		

Cabinet with single pull-out – horizontal bracket profile

Space requirement and safety distance – power supply unit housing

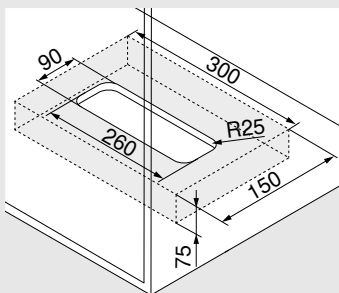

Base fixing

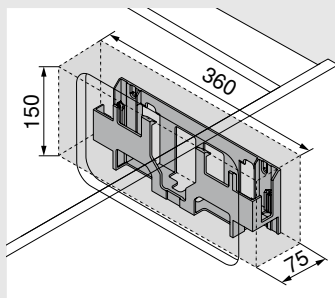

Back panel/wall fixing

Please note

Maintain a safety distance of 30 mm for air circulation. Otherwise there is a risk that the SERVO-DRIVE power supply unit could overheat. The dimensions in the drawing take the safety distance into account.

Front assembly – position – Blum distance bumper

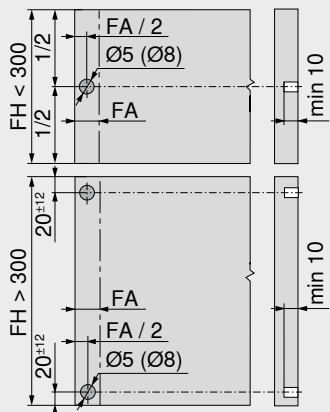

The Blum distance bumper ensures the required trigger path of 2 mm

Front height FH (mm)	Blum distance bumper (pcs)
Up to 300	2
From 301	4

FA Front overlay

FH Front height

Notes

Cabinet with single pull-out – upper attachment bracket



- Electrical motion support system in combination with BLUMOTION for soft and effortless closing
- With upper attachment bracket
- No fixed connection between the drive unit and pull-out
- Pull-outs need not be modified
- Quick installation of pre-assembled parts

Space requirement

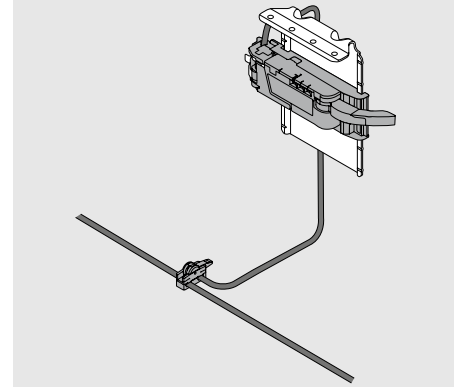

Ordering information

Blum distance bumper			
	Ø (mm)	Colour	
	5	TGR	993.0530
	8	TGR	993.0830.01
Up to front height 300 mm, use 2 pcs			
From front height 300 mm, use 4 pcs			
For LEGRABOX/MERIVOBX 70 kg cabinet profile, use 4 pcs			
For TANDEMBOX 65 kg cabinet profile, use 4 pcs			

Upper attachment bracket			
	Colour	Material	
	TGR/ZN	Steel	Z10D6252
Includes pre-mounted adapter for drive unit			

Drive unit			
	Colour	Material	
	TGR	K	Z10A3000.04
Incl. pre-mounted lever extension			

Lever cap for LEGRABOX			
	Colour	Material	
	SZ	K	Z10A3006
Steel back			
Required from height M and internal cabinet width LW of 267–286 mm			

Trigger guidance for TANDEMBOX			
	Colour	Material	
	R7037	K	Z10A3H00
Chipboard back			
Required for an LW of 242–316 mm			

SERVO-DRIVE distribution cable and cable end protector			
	Colour	Length (m)	
	SZ	8	Z10K800AE
Consisting of:			
1x SERVO-DRIVE distribution cable			
5x cable end protectors			
For cutting to size			
Can be used as distribution, bracket profile and communication cable			

Connecting node and cable end protector			
	Colour	Material	
	SZ	K	Z10V100E.01
Consisting of:			
1x connecting node			
2x cable end protectors			

Cabinet with single pull-out – upper attachment bracket

SERVO-DRIVE power supply unit incl. flex					
Markets	Language packages		Markets	Language packages	
E	A	Z10NE04EA	I	A	Z10NE04IA
E	B	Z10NE04EB	K	I	Z10NE04KI
E	C	Z10NE04EC	N	H	Z10NE04NH
E	D	Z10NE04ED	R	H	Z10NE04RH
E	E	Z10NE04EE	S	K	Z10NE04SK
E	F	Z10NE04EF	T	H	Z10NE04TH
E	I	Z10NE04EI	U	G	Z10NE04UG
B	A	Z10NE04BA	U	J	Z10NE04UJ
B	I	Z10NE04BI	Z	I	Z10NE04ZI
H	I	Z10NE04HI			
Incl. operating and installation instructions					
Consisting of:					
	1 x	Power supply unit (output flex: length 2 m)			
	1 x	Flex (1.5–1.8 m, incl. plug)			

Power supply unit housing			
	Back panel/wall fixing		
	Colour	Material	
	WGR	K	Z10NG120
For SERVO-DRIVE power supply unit			

Alternative

Power supply unit housing			
	Base fixing		
	Colour	Material	
	TGR	K	Z10NG000
Incl. cover			
For SERVO-DRIVE power supply unit			

Accessories

Cable holder			
	Colour	Material	
	WS	K	Z10K0009
E.g. for fixing the SERVO-DRIVE distribution cable			

Front/base stabiliser			
	Colour	Material	
	R7037	K	Z96.10E1

Markets and language packages

Code			
Markets		Language packages*	
E	Europe	A	DE, EN, FR, IT, NL
B	GB	B	DA, EN, FI, NO, SV
H	IN	C	EL, EN, HR, SR, SL, TR
I	IL	D	EN, ES, FR, IT, PT
K	AU	E	CS, HU, PL, SK
N	CN	F	BG, ET, LV, LT, RO, RU, GB
R	KR	G	EN, ES, FR
S	BR	H	EN, ZH, KO
T	TW	I	EN
U	US CA JP	J	JA
Z	ZA	K	EN, ES, PT

* Language code according to the ISO 639 standard

Cabinet with single pull-out – upper attachment bracket

Planning

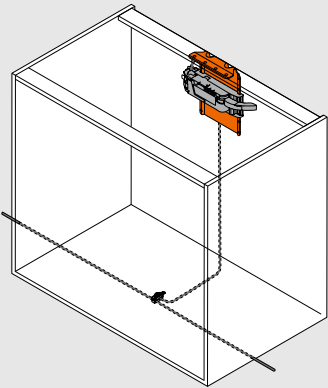
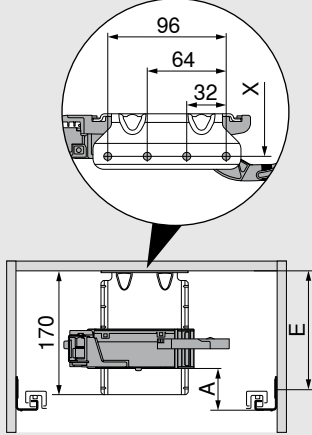
Cabinet	Position of drive unit
	
	<p>A Distance between bottom edge of cabinet profile and bottom edge of drive unit</p> <p>E Distance between bottom edge of cabinet top panel and fixing position of cabinet profile</p> <p>X Drilling position</p>
<p>The cross member must be securely fixed to the worktop area</p>	

Position – drive unit – box systems			Internal cabinet width LW (mm)											
Box system	Back	Back height	242–266			267–286			287–316			≥ 317		
			A (mm)	E min. (mm)	E max. (mm)	A (mm)	E min. (mm)	E max. (mm)	A (mm)	E min. (mm)	E max. (mm)	A (mm)	E min. (mm)	E max. (mm)
LEGRABOX	Chipboard back	N	–	–	–	–	–	–	45	84	174	45	84	174
		M K C F	–	–	–	45	84	174	45	84	174	45	84	174
	Steel back	N	–	–	–	–	–	–	–	–	–	–	–	–
		M K C F	–	–	–	45	84	174	45	84	174	45	84	174
MERIVOBX	Chipboard back	N	–	–	–	28	50	139	28	50	139	28	50	139
		M K E F	–	–	–	45	67	157	45	67	157	45	67	157
	Steel back	N	–	–	–	–	–	–	–	–	–	–	–	–
		M K E F	–	–	–	45	67	157	45	67	157	45	67	157
TANDEMBOX	Chipboard back	N	35	79	180	35	79	180	35	79	180	28	79	180
		M K B C D	35	79	180	35	79	180	35	79	180	35	79	180
	Steel back	N	–	–	–	–	–	–	28	79	180	28	79	180
		M K B C D	–	–	–	35	79	180	35	79	180	35	79	180

A Distance between bottom edge of cabinet profile and bottom edge of drive unit

E Distance between bottom edge of cabinet top panel and fixing position of cabinet profile

– Not possible

Cabinet with single pull-out – upper attachment bracket

Position – drive unit – runner systems										
Runner system	Drawer height SKH (mm)	Internal cabinet width LW (mm)								
		224–234			235–428			≥ 429		
		A (mm)	E min. (mm)	E max. (mm)	A (mm)	E min. (mm)	E max. (mm)	A (mm)	E min. (mm)	E max. (mm)
MOVENTO	≥ 79	–	–	–	60	100	190	35	75	165
TANDEM	≥ 79	55	96	187	55	96	187	35	75	167

A Distance between bottom edge of cabinet profile and bottom edge of drive unit
 E Distance between bottom edge of cabinet top panel and fixing position of runner
 LW Internal cabinet width
 – Not possible

Drilling distances for box systems			
	Back	X (mm)	Y (mm)
	Chipboard back	NL - 1	NL + 34
	Steel back	NL - 18	NL + 17
	NL Nominal length		
	X Drilling position		
	Y Min. space requirement		
	Z Dimension of engagement		

Box system	Back	Back height	Internal cabinet width LW (mm)									
			242–266			267–286				287–316		
			Z (mm)	Lever extension	Trigger guidance	Z (mm)	Lever extension	Trigger guidance	Lever cap	Z (mm)	Lever extension	Trigger guidance
LEGRABOX	Chipboard back	N	–	–	–	184	●	–	–	184	●	–
		M K C F	–	–	–	184	●	–	–	184	●	–
	Steel back	N	–	–	–	–	–	–	–	–	–	–
		M K C F	–	–	–	184	✘	–	●	184	●	–
MERIVOBX	Chipboard back	N	–	–	–	174	✘	–	–	174	●	–
		M K E F	–	–	–	174	✘	–	–	174	●	–
	Steel back	N	–	–	–	–	–	–	–	–	–	–
		M K E F	–	–	–	174	●	–	–	174	●	–
TANDEMBOX	Chipboard back	N	179	✘	●	179	●	●	–	179	●	●
		M K B C D	179	✘	●	179	●	●	–	179	●	●
	Steel back	N	–	–	–	–	–	–	–	190	✘	–
		M K B C D	–	–	–	179	✘	–	–	179	●	–

LW Internal cabinet width	○ Not required
Z Dimension of engagement	– Not possible
● Required	✘ Remove

Cabinet with a single drawer – upper attachment bracket

Box system	Back	Back height	Internal cabinet width LW (mm)					
			317–386			≥ 387		
			Z (mm)	Lever extension	Trigger guidance	Z (mm)	Lever extension	Trigger guidance
LEGRABOX	Chipboard back	N	184	●	–	LW / 2	●	–
		M K C F	184	●	–	LW / 2	●	–
	Steel back	N	–	–	–	–	–	–
		M K C F	184	●	–	LW / 2	●	–
MERIVOBX	Chipboard back	N	174	●	–	LW / 2	●	–
		M K E F	174	●	–	LW / 2	●	–
	Steel back	N	–	–	–	–	–	–
		M K E F	174	●	–	LW / 2	●	–
TANDEMBOX	Chipboard back	N	179	●	○	LW / 2	●	○
		M K B C D	179	●	○	LW / 2	●	○
	Steel back	N	190	●	–	LW / 2	●	–
		M K B C D	179	●	–	LW / 2	●	–

LW Internal cabinet width	○ Not required
Z Dimension of engagement	– Not possible
● Required	✘ Remove

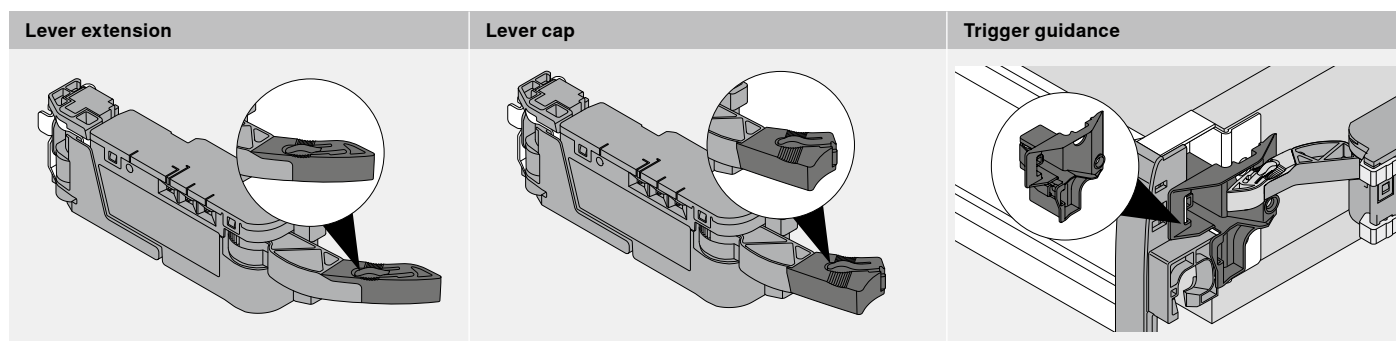

Space requirement and safety distance – power supply unit housing		Please note
Base fixing	Back panel/wall fixing	

Cabinet with a single drawer – upper attachment bracket

Drilling distances for runner systems

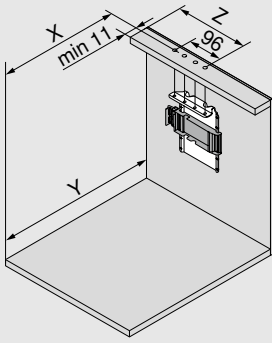

Drawer height SKH (mm)	X (mm)	Y (mm)
≥ 79	NL – 5	NL + 30
NL Nominal length		
X Drilling position		
Y Min. space requirement		
Z Dimension of engagement		

Runner system	Drawer height SKH (mm)	Internal cabinet width LW (mm)							
		224–234		235–388		389–428		≥ 429	
		Z (mm)	Lever extension	Z (mm)	Lever extension	Z (mm)	Lever extension	Z (mm)	Lever extension
MOVENTO	≥ 79	–	–	164	●	164	●	LW / 2	●
TANDEM	≥ 79	164	–	164	●	LW / 2	●	LW / 2	●

LW Internal cabinet width

Z Dimension of engagement

● Required

– Not possible

Front assembly – position – Blum distance bumper

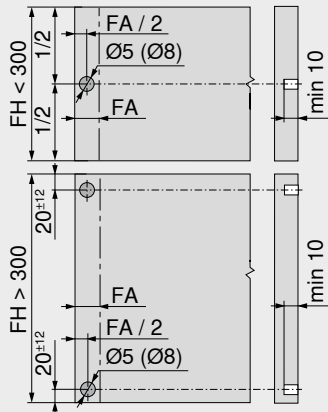

The Blum distance bumper ensures the required trigger path of 2 mm

Front height FH (mm)	Blum distance bumper (pcs)
Up to 300	2
From 301	4

FA Front overlay

FH Front height

Two drawers with a single front



- Electrical motion support system in combination with BLUMOTION for soft and effortless closing
- Synchronised triggering of two drawers and/or wide applications
- With attachment bracket
- No fixed connection between the drive unit and pull-out
- Pull-outs need not be modified
- Quick installation of pre-assembled parts

Cabling

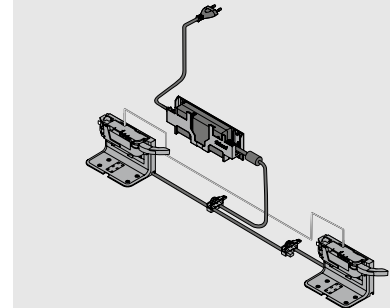

Ordering information

Blum distance bumper			
	Ø (mm)	Colour	
	5	TGR	993.0530
	8	TGR	993.0830.01

Up to front height 300 mm, use 2 pcs
From front height 300 mm, use 4 pcs

Attachment bracket 1 tier			
	Colour	Material	
	TGR	K	Z10D0311

For 1 drive unit

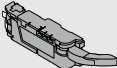
Drive unit			
	Colour	Material	
	TGR	K	Z10A3000.04

Incl. pre-mounted lever extension

SERVO-DRIVE distribution cable and cable end protector			
	Colour	Length (m)	
	SZ	8	Z10K800AE

Consisting of:

1x SERVO-DRIVE distribution cable

5x cable end protectors

For cutting to size

Can be used as distribution, bracket profile and communication cable

Connecting node and cable end protector			
	Colour	Material	
	SZ	K	Z10V100E.01

Consisting of:

1x connecting node
2x cable end protectors

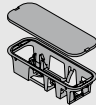
Power supply unit housing			
	Base fixing		
	Colour	Material	
	TGR	K	Z10NG000

Incl. cover
For SERVO-DRIVE power supply unit

Alternative

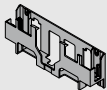
Power supply unit housing			
	Back panel/wall fixing		
	Colour	Material	
	WGR	K	Z10NG120

For SERVO-DRIVE power supply unit

Accessories

Cable holder			
	Colour	Material	
	WS	K	Z10K0009

E.g. for fixing the SERVO-DRIVE distribution cable

Two drawers with a single front

SERVO-DRIVE power supply unit incl. flex					
Markets	Language packages		Markets	Language packages	
E	A	Z10NE04EA	I	A	Z10NE04IA
E	B	Z10NE04EB	K	I	Z10NE04KI
E	C	Z10NE04EC	N	H	Z10NE04NH
E	D	Z10NE04ED	R	H	Z10NE04RH
E	E	Z10NE04EE	S	K	Z10NE04SK
E	F	Z10NE04EF	T	H	Z10NE04TH
E	I	Z10NE04EI	U	G	Z10NE04UG
B	A	Z10NE04BA	U	J	Z10NE04UJ
B	I	Z10NE04BI	Z	I	Z10NE04ZI
H	I	Z10NE04HI			
Incl. operating and installation instructions					
Consisting of:					
1 x	Power supply unit (output flex: length 2 m)				
1 x	Flex (1.5–1.8 m, incl. plug)				

Markets and language packages

Code			
Markets		Language packages*	
E	Europe	A	DE, EN, FR, IT, NL
B	GB	B	DA, EN, FI, NO, SV
H	IN	C	EL, EN, HR, SR, SL, TR
I	IL	D	EN, ES, FR, IT, PT
K	AU	E	CS, HU, PL, SK
N	CN	F	BG, ET, LV, LT, RO, RU, UK
R	KR	G	EN, ES, FR
S	BR	H	EN, ZH, KO
T	TW	I	EN
U	US CA JP	J	JA
Z	ZA	K	EN, ES, PT

* Language code according to the ISO 639 standard

Synchronisation cable		
	Length (mm)	
	80	Z10K008S
	500	Z10K050S
	1200	Z10K120S
	1600	Z10K160S
Connects two drive units that need to open simultaneously		

Planning

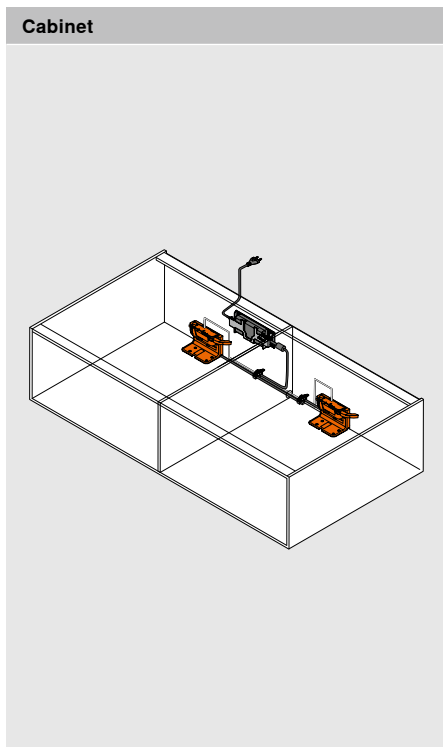

Cabinet base – attachment bracket 1 tier		
	X	Drilling position
	A	Distance between bottom edge of attachment bracket and bottom edge of drive unit
	*	Measured from cabinet front edge
Runner system	Drawer height SKH (mm)	Internal cabinet width LW (mm)
		≥ 429
		A (mm)
MOVENTO	≥ 79	35
TANDEM	≥ 79	35

Two drawers with a single front – attachment bracket 1 tier

Cabinet base – attachment bracket 1 tier

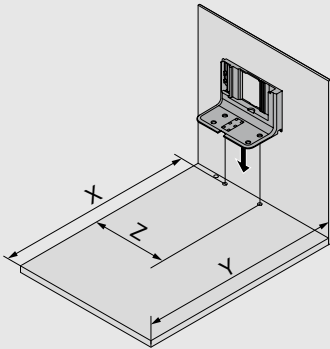

Drawer height SKH (mm)	X (mm)	Y (mm)	Z (mm)
≥ 79	NL + 16	NL + 30	LW / 2
LW Internal cabinet width			
NL Nominal length			
X Drilling position			
Y Min. space requirement			
Z Dimension of engagement			

Front assembly – position – Blum distance bumper

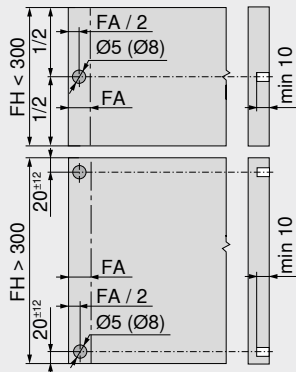

The Blum distance bumper ensures the required trigger path of 2 mm

Front height FH (mm)	Blum distance bumper (pcs)
Up to 300	2
From 301	4
FA Front overlay	
FH Front height	

Two drawers with a single front – attachment bracket 1 tier

Cabinet base – drilling pattern

Lower cabling

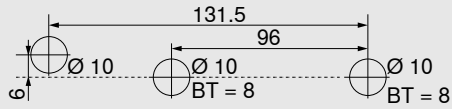
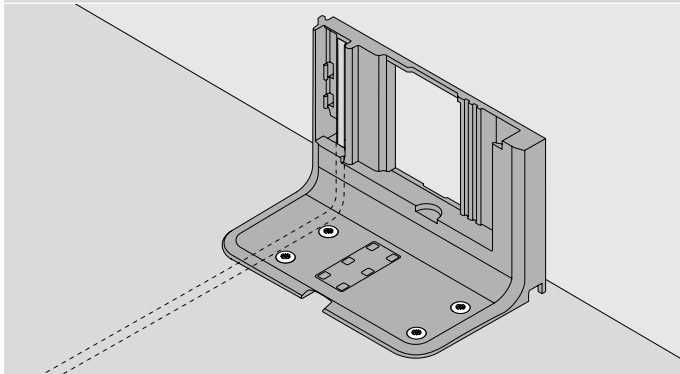

Back cabling

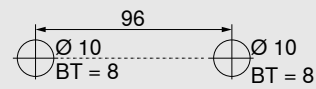
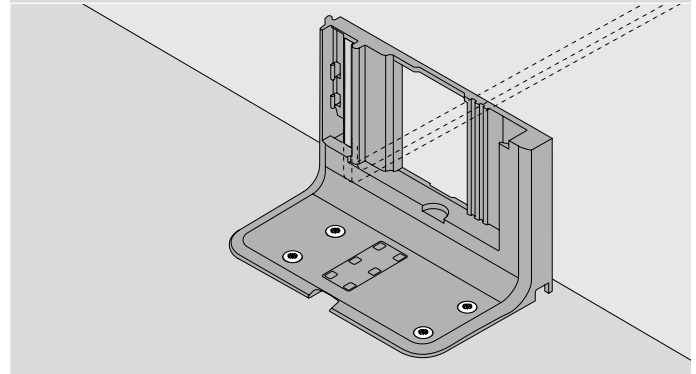

Alternative drilling pattern for MINIPRESS top and MINIPRESS

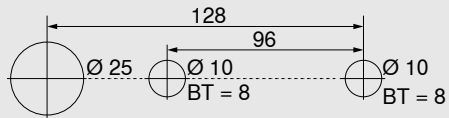

BT Drilling depth

Space requirement and safety distance – power supply unit housing

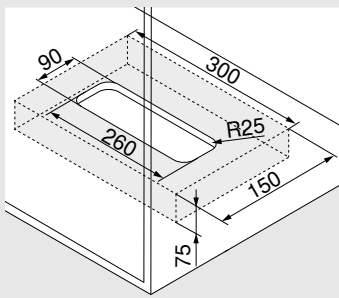

Base fixing

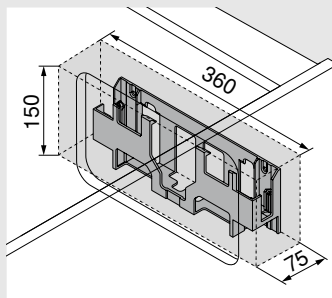

Back panel/wall fixing

Please note

Maintain a safety distance of 30 mm for air circulation. Otherwise there is a risk that the SERVO-DRIVE power supply unit could overheat. The dimensions in the drawing take the safety distance into account.

Cabinet with different drawer depths/inner drawer



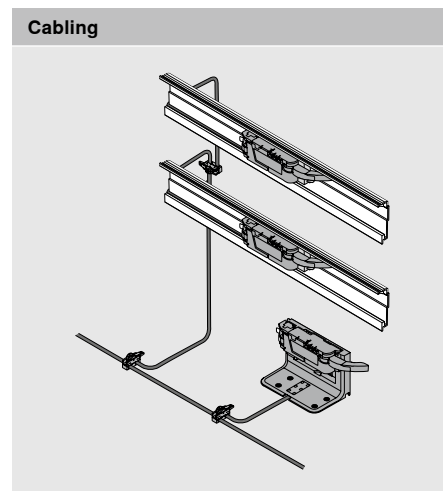

- Electrical motion support system in combination with BLUMOTION for soft and effortless closing
- With attachment bracket and horizontal bracket profile
- No fixed connection between the drive unit and pull-out
- Pull-outs need not be modified
- Quick installation of pre-assembled parts

Cablings



Ordering information

Blum distance bumper			
	Ø (mm)	Colour	
	5	TGR	993.0530
	8	TGR	993.0830.01
Up to front height 300 mm, use 2 pcs			
From front height 300 mm, use 4 pcs			

Blum distance bumper – inner drawer			
	Ø (mm)		
	10		993.2000
	TANDEM		
Adjustable Blum distance bumper for inner drawers and inset fronts with TANDEM			

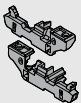
Depth adjustment – inner drawer		
	MOVENTO	298.7600
Only for inset applications		
Integrated Blum distance bumper		
Suitable for T51.7601 locking device		

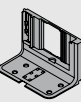
Attachment bracket 1 tier			
	Colour	Material	
	TGR	K	Z10D0311
For 1 drive unit			

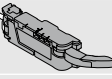
Drive unit			
	Colour	Material	
	TGR	K	Z10A3000.04
Incl. pre-mounted lever extension			

Horizontal bracket profile			
	Length (mm)	Material	
	1143	Alu	Z10T1143B
For cabinet width KB 275–1200 mm			
Cutting:	Internal cabinet width LW – 19 mm		

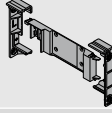
Horizontal bracket profile attachment			
	Colour	Material	
	TGR	K	Z10D5210
Consisting of:			
1x bracket profile attachment left/right			
1x bracket profile adapter for drive unit			
Chipboard screws and system screws can be used			

SERVO-DRIVE distribution cable and cable end protector			
	Colour	Length (m)	
	SZ	8	Z10K800AE
Consisting of:			
1x SERVO-DRIVE distribution cable			
5x cable end protectors			
For cutting to size			
Can be used as distribution, bracket profile and communication cable			

Cabinet with different drawer depths/inner drawer

SERVO-DRIVE power supply unit incl. flex					
Markets	Language packages		Markets	Language packages	
E	A	Z10NE04EA	I	A	Z10NE04IA
E	B	Z10NE04EB	K	I	Z10NE04KI
E	C	Z10NE04EC	N	H	Z10NE04NH
E	D	Z10NE04ED	R	H	Z10NE04RH
E	E	Z10NE04EE	S	K	Z10NE04SK
E	F	Z10NE04EF	T	H	Z10NE04TH
E	I	Z10NE04EI	U	G	Z10NE04UG
B	A	Z10NE04BA	U	J	Z10NE04UJ
B	I	Z10NE04BI	Z	I	Z10NE04ZI
H	I	Z10NE04HI			
Incl. operating and installation instructions					
Consisting of:					
1 x	Power supply unit (output flex: length 2 m)				
1 x	Flex (1.5–1.8 m, incl. plug)				

Markets and language packages

Code		
Markets	Language packages*	
E Europe	A	DE, EN, FR, IT, NL
B GB	B	DA, EN, FI, NO, SV
H IN	C	EL, EN, HR, SR, SL, TR
I IL	D	EN, ES, FR, IT, PT
K AU	E	CS, HU, PL, SK
N CN	F	BG, ET, LV, LT, RO, RU, UK
R KR	G	EN, ES, FR
S BR	H	EN, ZH, KO
T TW	I	EN
U US CA JP	J	JA
Z ZA	K	EN, ES, PT

* Language code according to the ISO 639 standard

Connecting node and cable end protector			
	Colour	Material	
	SZ	K	Z10V100E.01
Consisting of:			
1x connecting node			
2x cable end protectors			

Power supply unit housing			
	Base fixing		
	Colour	Material	
	TGR	K	Z10NG000
Incl. cover			
For SERVO-DRIVE power supply unit			

Alternative

Power supply unit housing			
	Back panel/wall fixing		
	Colour	Material	
	WGR	K	Z10NG120
For SERVO-DRIVE power supply unit			

Accessories

Cable holder			
	Colour	Material	
	WS	K	Z10K0009
E.g. for fixing the SERVO-DRIVE distribution cable			

Cabinet with different drawer depths/inner drawer – horizontal bracket profile

Planning

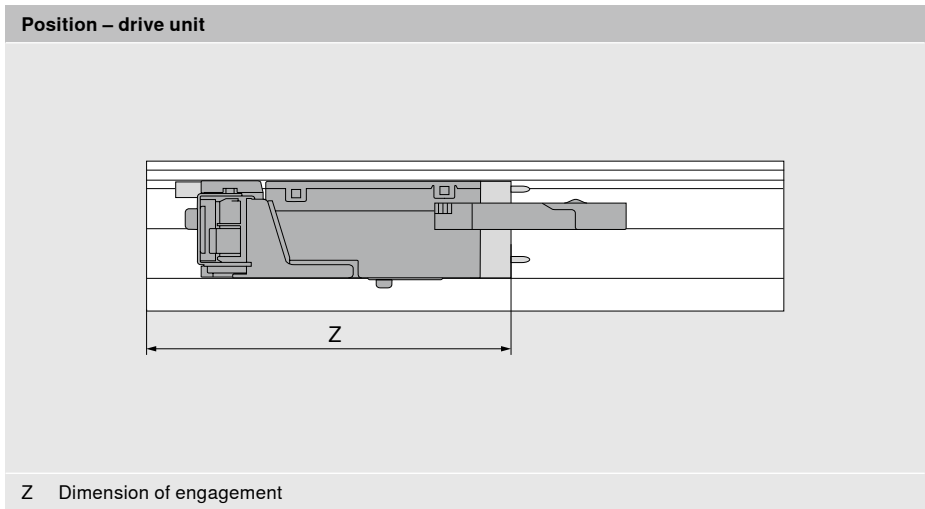
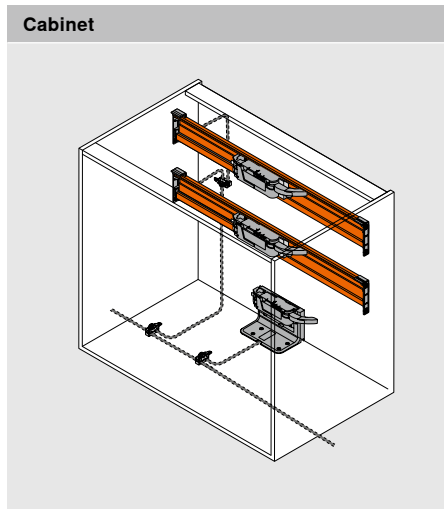

Runner system	Drawer height SKH (mm)	Internal cabinet width LW (mm)							
		224–234		235–388		389–428		≥ 429	
		Z (mm)	Lever extension	Z (mm)	Lever extension	Z (mm)	Lever extension	Z (mm)	Lever extension
MOVENTO	≥ 79	167	–	167	●	167	●	LW / 2	●
TANDEM	≥ 79	167	–	167	●	LW / 2	●	LW / 2	●

LW Internal cabinet width
 Z Dimension of engagement
 ● Required
 – Not possible

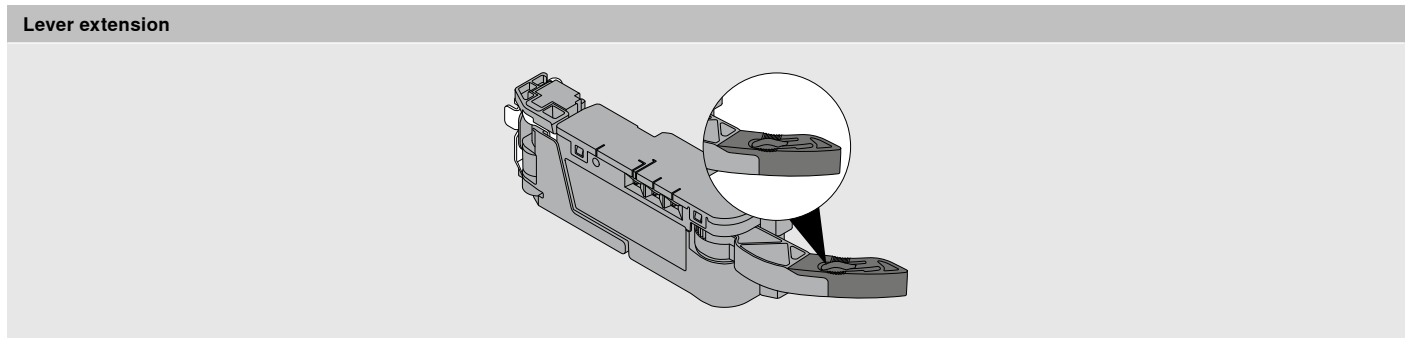

Front assembly – position of Blum distance bumper

Runners	Type of extension	B (mm)	C (mm)
56xH / 56xF	Full extension	16.5 ±1	12.0 +1
55xH / 55xF	Single extension	18.5 ±0.5	13.5 ±0.5

Front thickness FD (mm)	Drilling depth BT (mm)	Adjustment range (mm)
13.0	10.0	+1.75 / -0.25
From 14.5	11.5	±1.75

TANDEM
 Inner drawer
 The Blum distance bumper ensures the required trigger path of 2 mm

Drilling distances

MOVENTO

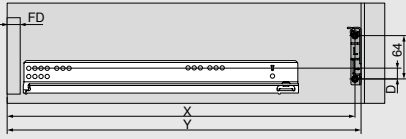

TANDEM

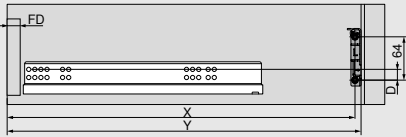

Drawer height SKH (mm)	X (mm)	Y (mm)
≥ 79	NL + FD + 26	NL + FD + 36
FD Front thickness		
NL Nominal length		
X Drilling position		
Y Min. space requirement		

Runner system	Drawer height SKH (mm)	Internal cabinet width LW (mm)
		D (mm)
MOVENTO	≥ 79	≥ 429 19
TANDEM	≥ 79	19

D Distance from cabinet profile fixing position to bracket profile attachment fixing position

Cabinet

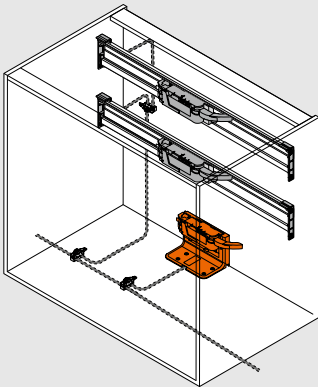

Position – drive unit

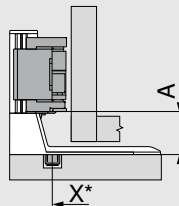

- X Drilling position
- A Distance between bottom edge of attachment bracket and bottom edge of drive unit
- * Measured from cabinet front edge

Runner system	Drawer height SKH (mm)	Internal cabinet width LW (mm)
		A (mm)
MOVENTO	≥ 79	≥ 429 35
TANDEM	≥ 79	35

Drilling distances – cabinet base

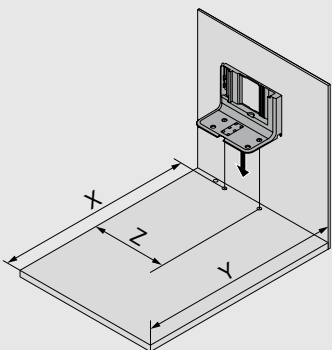

Drawer height SKH (mm)	X (mm)	Y (mm)	Z (mm)
≥ 79	NL + 16	NL + 30	LW / 2
LW Internal cabinet width			
NL Nominal length			
X Drilling position			
Y Min. space requirement			
Z Dimension of engagement			

Cabinet with different drawer depths/inner drawer – horizontal bracket profile

Cabinet base – drilling pattern

Lower cabling

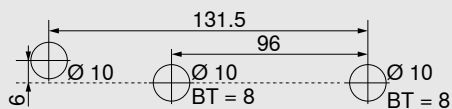
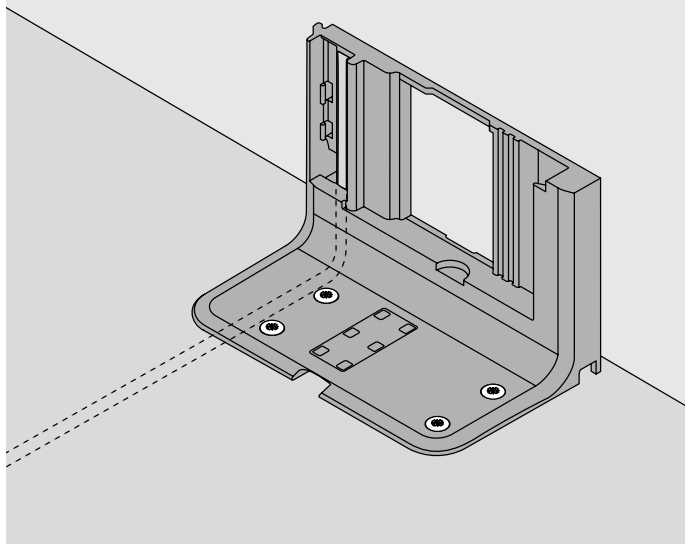

Back cabling

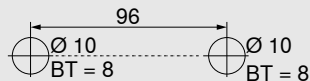
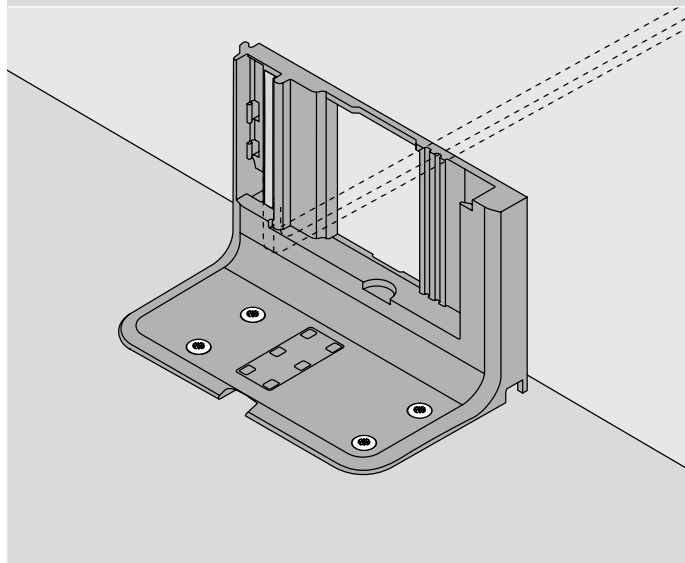

Alternative drilling pattern for MINIPRESS top and MINIPRESS

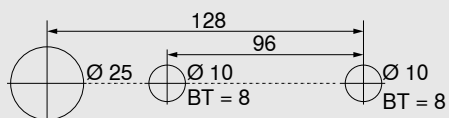

BT Drilling depth

Space requirement and safety distance – power supply unit housing

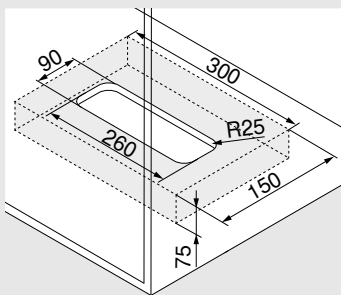

Base fixing

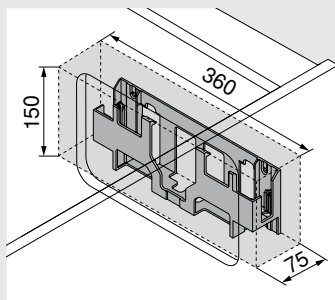

Back panel/wall fixing

Please note

Maintain a safety distance of 30 mm for air circulation. Otherwise there is a risk that the SERVO-DRIVE power supply unit could overheat. The dimensions in the drawing take the safety distance into account.

Notes

Cabinet with inset fronts



- Electrical motion support system in combination with BLUMOTION for soft and effortless closing
- With vertical bracket profile
- No fixed connection between the drive unit and pull-out
- Pull-outs need not be modified
- Tool-free drive unit assembly
- Simple cabling

Cabling

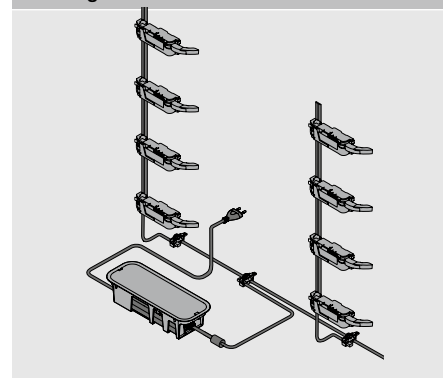

Ordering information

Blum distance bumper – inner drawer		
	Ø (mm)	
	10	993.2000
	TANDEM	
Adjustable Blum distance bumper for inner drawers and inset fronts with TANDEM		

Depth adjustment – inner drawer		
	MOVENTO	298.7600
Only for inset applications		
Integrated Blum distance bumper		
Suitable for T51.7601 locking device		

Bracket profile				
	Bracket profile with SERVO-DRIVE distribution cable			
	Length (mm)			
	650	Z10T650AA	750	Z10T750AA
	700	Z10T700AA	800	Z10T800AA
	710	Z10T710AA		
	Bracket profile without SERVO-DRIVE distribution cable			
	Length (mm)			
	1170		Z10T1170A	
Aluminium for cutting to size				
Cutting:	Internal cabinet height LH - 10 mm			

Bracket profile attachment top/bottom			
	Horizontal cross member		
	Colour	Material	
	TGR	K	Z10D01E0.01

Alternative to 3

Bracket profile attachment bottom/back			
	Vertical cross member		
	Colour	Material	
	TGR	K	Z10D01EA.01

Drive unit			
	Colour	Material	
	TGR	K	Z10A3000.04
Incl. pre-mounted lever extension			

SERVO-DRIVE distribution cable and cable end protector			
	Colour	Length (m)	
	SZ	8	Z10K800AE

Consisting of:

1x SERVO-DRIVE distribution cable

5x cable end protectors

For cutting to size

Can be used as distribution, bracket profile and communication cable

Connecting node and cable end protector			
	Colour	Material	
	SZ	K	Z10V100E.01

Consisting of:

1x connecting node

2x cable end protectors

Cabinet with inset fronts

SERVO-DRIVE power supply unit incl. flex					
Markets	Language packages		Markets	Language packages	
E	A	Z10NE04EA	I	A	Z10NE04IA
E	B	Z10NE04EB	K	I	Z10NE04KI
E	C	Z10NE04EC	N	H	Z10NE04NH
E	D	Z10NE04ED	R	H	Z10NE04RH
E	E	Z10NE04EE	S	K	Z10NE04SK
E	F	Z10NE04EF	T	H	Z10NE04TH
E	I	Z10NE04EI	U	G	Z10NE04UG
B	A	Z10NE04BA	U	J	Z10NE04UJ
B	I	Z10NE04BI	Z	I	Z10NE04ZI
H	I	Z10NE04HI			
Incl. operating and installation instructions					
Consisting of:					
1 x	Power supply unit (output flex: length 2 m)				
1 x	Flex (1.5–1.8 m, incl. plug)				

Power supply unit housing			
	Base fixing		
	Colour	Material	
	TGR	K	Z10NG000
Incl. cover			
For SERVO-DRIVE power supply unit			

Alternative

Power supply unit housing			
	Back panel/wall fixing		
	Colour	Material	
	TGR	K	Z10NG120
For SERVO-DRIVE power supply unit			

Accessories

Cable holder			
	Colour	Material	
	WS	K	Z10K0009
E.g. for fixing the SERVO-DRIVE distribution cable			

Markets and language packages

Code		Language packages*	
Markets		Language packages*	
E	Europe	A	DE, EN, FR, IT, NL
B	GB	B	DA, EN, FI, NO, SV
H	IN	C	EL, EN, HR, SR, SL, TR
I	IL	D	EN, ES, FR, IT, PT
K	AU	E	CS, HU, PL, SK
N	CN	F	BG, ET, LV, LT, RO, RU, UK
R	KR	G	EN, ES, FR
S	BR	H	EN, ZH, KO
T	TW	I	EN
U	US CA JP	J	JA
Z	ZA	K	EN, ES, PT

* Language code according to the ISO 639 standard

Cabinet with inset fronts

Planning

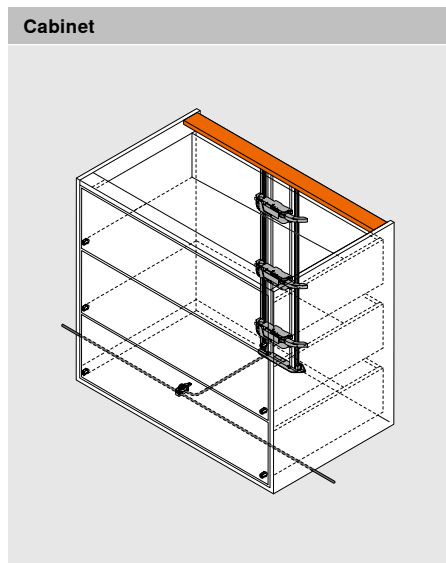

Position – drive unit

PL = LH – 10 mm

Round down to the nearest tenth

LH Internal cabinet height

PL Bracket profile length

A Distance between bottom edge of cabinet profile and bottom edge of drive unit

E Distance between bottom edge of cabinet top panel and fixing position of runner

Position – drive unit

Runner system	Drawer height SKH (mm)	Internal cabinet width LW (mm)					
		224–234		235–428		≥ 429	
		A (mm)	E min. (mm)	A (mm)	E min. (mm)	A (mm)	E min. (mm)
MOVENTO	≥ 79	–	–	60	74	35	49
TANDEM	≥ 79	55	71	55	71	35	51

A Distance between bottom edge of cabinet profile and bottom edge of drive unit

E Distance between bottom edge of cabinet top panel and fixing position of runner

– Not possible

Drilling distances – cabinet base | cross member

Back	X (mm)	Y (mm)
≥ 79	NL + FD + 18	NL + FD + 34

FD Front thickness

NL Nominal length

X Drilling position

Y Min. space requirement

Z Dimension of engagement

Runner system	Drawer height SKH (mm)	Internal cabinet width LW (mm)							
		224–234		235–388		389–428		≥ 429	
		Z (mm)	Lever extension	Z (mm)	Lever extension	Z (mm)	Lever extension	Z (mm)	Lever extension
MOVENTO	≥ 79	–	–	164	●	164	●	LW / 2	●
TANDEM	≥ 79	164	–	164	●	LW / 2	●	LW / 2	●

LW Internal cabinet width

Z Dimension of engagement

● Required

– Not possible

Cabinet with inset fronts

Lever extension

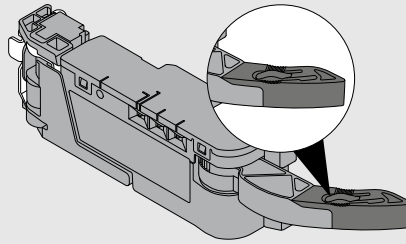

Cabinet base – drilling pattern

Lower cabling

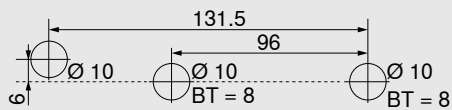
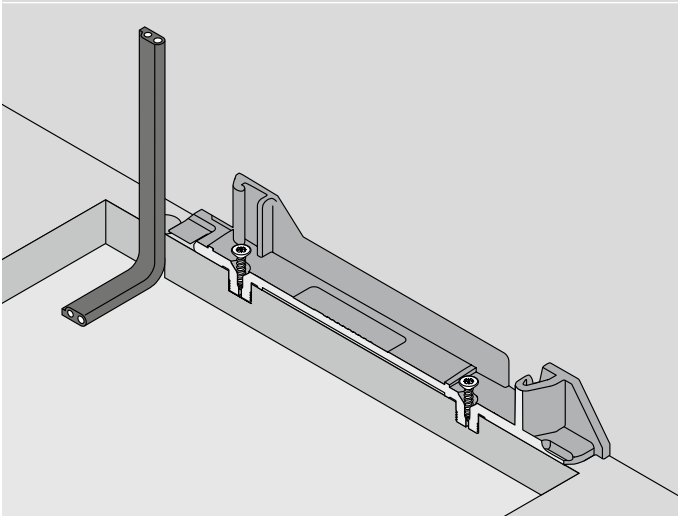

Back cabling

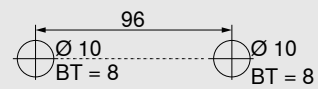
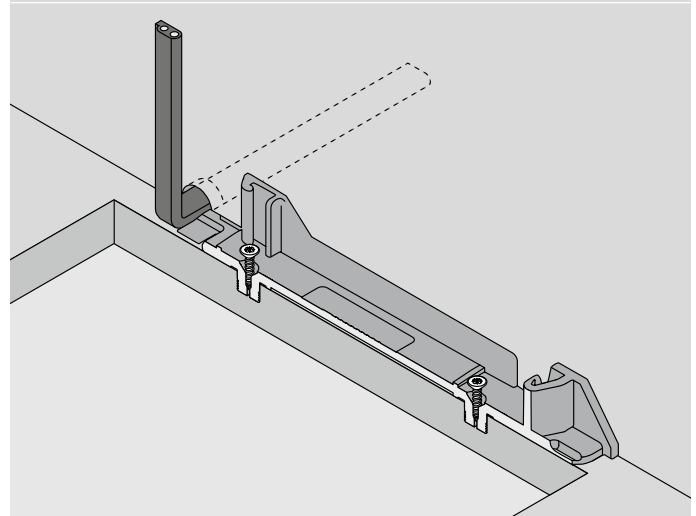

Alternative drilling pattern for MINIPRESS top and MINIPRESS

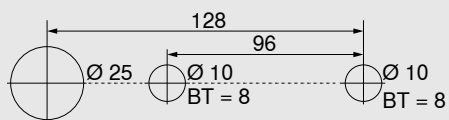

BT Drilling depth

Cabinet with inset fronts

Space requirement and safety distance – power supply unit housing

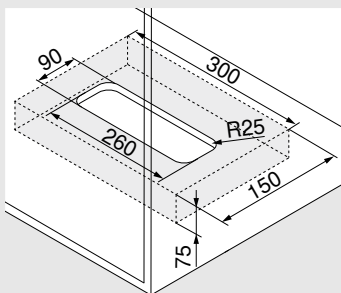

Base fixing

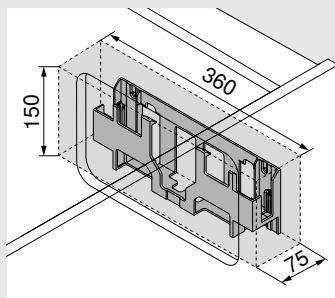

Back panel/wall fixing

Please note

Maintain a safety distance of 30 mm for air circulation. Otherwise there is a risk that the SERVO-DRIVE power supply unit could overheat. The dimensions in the drawing take the safety distance into account.

Front assembly – position of Blum distance bumper

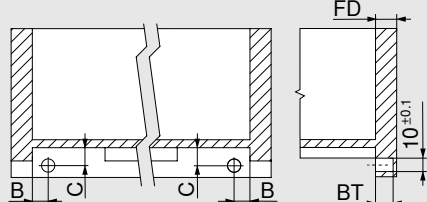

TANDEM

Inner drawer

The Blum distance bumper ensures the required trigger path of 2 mm

Runners	Type of extension	B (mm)	C (mm)
56xH / 56xF	Full extension	16.5 ±1	12.0 +-1
55xH / 55xF	Single extension	18.5 ±0.5	13.5 ±0.5

Front thickness FD (mm)	Drilling depth BT (mm)	Adjustment range (mm)
13.0	10.0	+1.75 / -0.25
From 14.5	11.5	±1.75

Notes

Bottom mount waste bin solution for box and runner systems

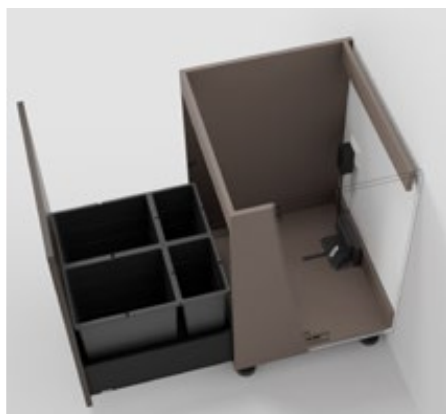

- Electrical motion support system in combination with BLUMOTION for soft and effortless closing
- Suitable for single applications
- For bottom mount waste bin solutions
- Also ideal for retrofitting
- No fixed connection between the drive unit and pull-out
- Pull-outs need not be modified
- Quick and simple installation of pre-assembled parts



Ordering information

SERVO-DRIVE uno set						
	Network adapter	Language package		Network adapter	Language package	
	E	A	Z10UB00EA	B	A	Z10UB00BA
	E	B	Z10UB00EB	B	I	Z10UB00BI
	E	C	Z10UB00EC	K	I	Z10UB00KI
	E	D	Z10UB00ED	N	H	Z10UB00NH
	E	E	Z10UB00EE	U	G	Z10UB00UG
	E	F	Z10UB00EF	U	J	Z10UB00UJ

Network adapter

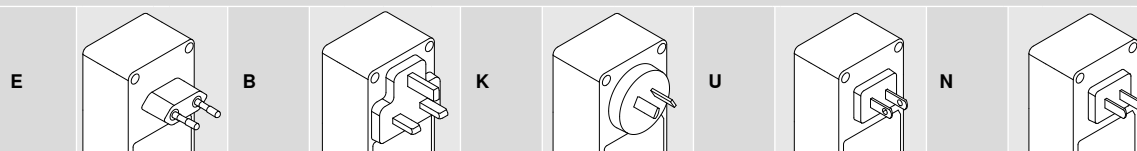

See the Information chapter of the Blum catalogue for a detailed market list.

Language package

A	DE, EN, FR, IT, NL	D	EN, ES, FR, IT, PT	G	EN, ES, FR	J	JA
B	DA, EN, FI, NO, SV	E	CS, HU, PL, SK	H	EN, ZH, KO		
C	EL, EN, HR, SL, SR, TR	F	BG, ET, LT, LV, RO, RU, UK	I	EN		

Pre-assembled set

Consisting of:

	2 x	Blum distance bumper
	1 x	Attachment bracket 1 tier
	1 x	Drive unit
	1 x	Transport protection
	1 x	Drip protection feature for attachment bracket 1 tier
	1 x	SERVO-DRIVE plug-in power supply unit
	1 x	Operating instructions
	1 x	Locating bracket
	7 x	Screws for Blum distance bumper and attachment bracket

Bottom mount waste bin solution for box and runner systems

Cabinet

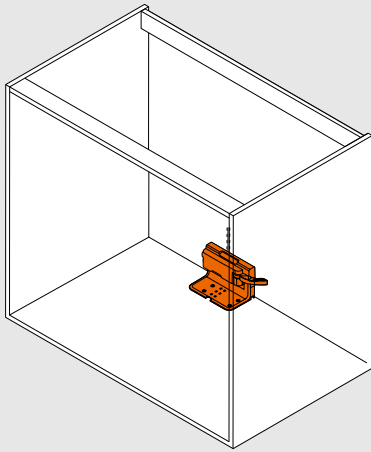

Position – drive unit – box systems

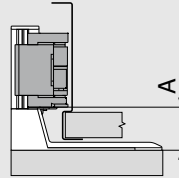

Box system	Internal cabinet width LW (mm)	
	≥ 387	
	A min. (mm)	A max. (mm)
LEGRABOX	45	47
MERIVOBX	28	45
TANDEMBOX	28	43

A Distance between bottom edge of runner and bottom edge of drive unit

Position – drive unit – runner systems

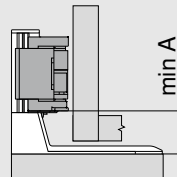

Runner system	Internal cabinet width LW (mm)	
	≥ 429	
	A (mm)	
MOVENTO	35	
TANDEM	35	

A Distance between bottom edge of attachment bracket and bottom edge of drive unit

Bottom mount waste bin solution for box and runner systems

Cabinet

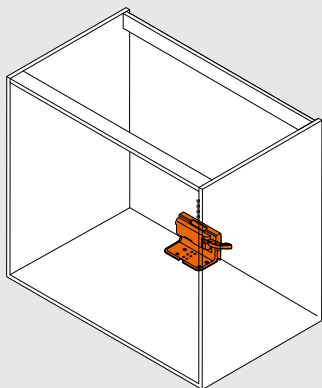

Drilling distances – cabinet base without locating bracket

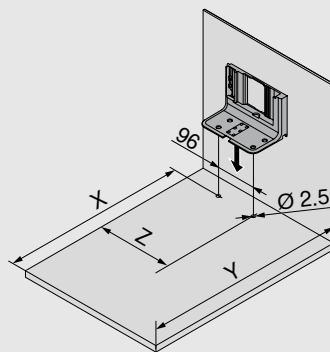

Box systems	Internal cabinet width LW (mm)		
	≥ 387		
	X (mm)	Y (mm)	Z (mm)
Chipboard back	NL - 45	NL + 35	LW / 2
Steel back	NL - 62	NL + 18	LW / 2

Runner system	Internal cabinet width LW (mm)		
	≥ 429		
	X (mm)	Y (mm)	Z (mm)
MOVENTO	NL - 48	NL + 30	LW / 2
TANDEM	NL - 48	NL + 30	LW / 2

NL Nominal length
 X Drilling position
 Y Min. space requirement
 Z Dimension of engagement

Position – Blum distance bumper

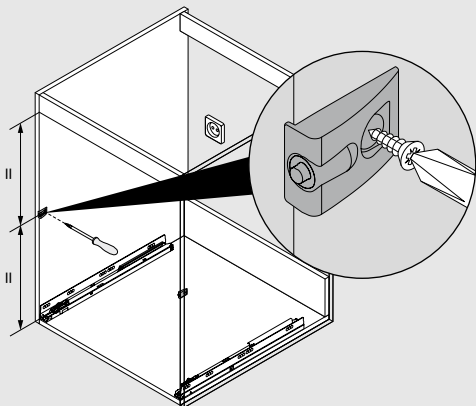

The Blum distance bumper ensures the required trigger path of 2 mm



Notes

Top mount waste bin solution for TANDEMBOX



- Electrical motion support system in combination with BLUMOTION for soft and effortless closing
- Suitable for single applications
- For top mount waste bin solutions
- Also ideal for retrofitting
- No fixed connection between the drive unit and pull-out
- Pull-outs need not be modified
- Quick and simple installation of pre-assembled parts



Ordering information

SERVO-DRIVE uno set					
Cabinet width KB (mm)	Network adapter	Language package			
		A	I		
450	E	A	DE, EN, FR, IT, NL		☎ Z10UT45EA
	K	I	EN		☎ Z10UT45KI
	U	G	EN, ES, FR		☎ Z10UT45UG
500	E	A	DE, EN, FR, IT, NL		☎ Z10UT50EA
	B	I	EN		☎ Z10UT50BI
600	E	A	DE, EN, FR, IT, NL		☎ Z10UT60EA
		B	DA, EN, FI, NO, SV		☎ Z10UT60EB
		E	CS, HU, PL, SK		☎ Z10UT60EE
	B	I	EN		☎ Z10UT60BI
	K	I	EN		☎ Z10UT60KI
850	U	G	EN, ES, FR		☎ Z10UT60UG
		B	DA, EN, FI, NO, SV		☎ Z10UT85EB
900	E	A	DE, EN, FR, IT, NL		☎ Z10UT90EA

See the Information chapter of the Blum catalogue for a detailed market list.

☎ Item only available on request

Pre-assembled set

Consisting of:

2 x	Blum distance bumper
1 x	Horizontal bracket profile
1 x	Bracket profile adapter for drive unit
1 x	Drive unit
1 x	Left/right bracket profile attachment
1 x	Drip protection feature for horizontal applications
1 x	SERVO-DRIVE plug-in power supply unit
6 x	Screws for Blum distance bumper
1 x	Installation instructions
1 x	Operating instructions

Top mount waste bin solution for TANDEMBOX

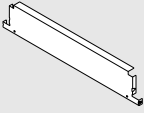
	Special back set		
	Colour	Nominal length NL (mm)	
	R9006	500	
	KB (mm)	SWD 15/16 mm	SWD 18/19 mm
	450	Z30M389S0W	Z30M383S0W
	500	Z30M439S0W	Z30M433S0W
	550	Z30M489S0W	Z30M483S0W
	600	Z30M539S0W	Z30M533S0W
800		Z30M733S0W	
900	Z30M839S0W	Z30M833S0W	

Consisting of:

- 1x steel back height M
- 1x steel back for waste bin pull-out
- 1x attachment left/right
- 1x rectangular longside gallery rail left/right
- KB Cabinet width
- SWD Cabinet side panel thickness

Colours and material

Code	
SW	Silk white
R9006	RAL 9006 grey (white aluminium)
TS	Terra black
WS	White
GR	Grey
NI	Nickel plated
TGR	Dark grey
WGR	White grey
SZ	Black

Planning

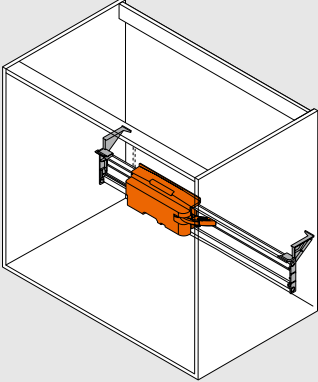
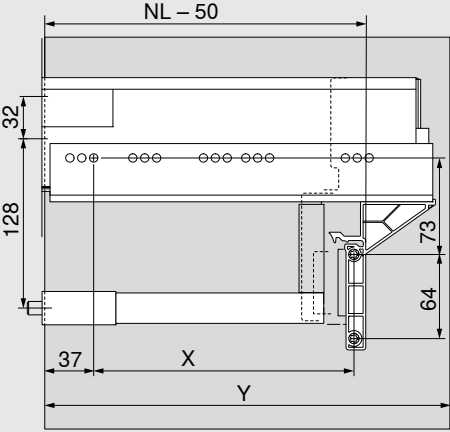
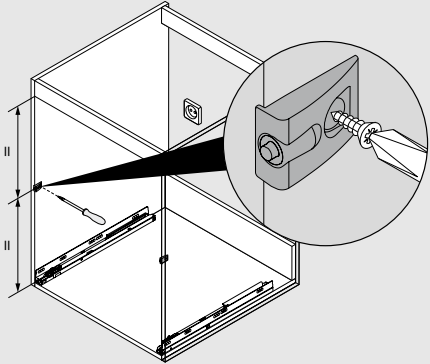
Cabinet	Position – bracket profile attachment	Position – Blum distance bumper											
													
	<table border="1"> <thead> <tr> <th rowspan="2">Box systems</th> <th colspan="2">Cabinet width KB (mm)</th> </tr> <tr> <th colspan="2">450–900</th> </tr> <tr> <td></td> <th>X (mm)</th> <th>Y (mm)</th> </tr> </thead> <tbody> <tr> <td>TANDEMBOX</td> <td>NL – 96</td> <td>NL + 3</td> </tr> </tbody> </table>	Box systems	Cabinet width KB (mm)		450–900			X (mm)	Y (mm)	TANDEMBOX	NL – 96	NL + 3	<p>The Blum distance bumper ensures the required trigger path of 2 mm</p> <p>When using a 65 kg TANDEMBOX cabinet profile, attach four Blum distance bumpers</p>
Box systems	Cabinet width KB (mm)												
	450–900												
	X (mm)	Y (mm)											
TANDEMBOX	NL – 96	NL + 3											
NL	Nominal length												
X	Drilling position												
Y	Min. space requirement												

Assembly devices

Drilling template for SERVO-DRIVE bracket profile attachment



- Template for marking or pre-drilling the fixing positions for the SERVO-DRIVE bracket profile attachment and attachment bracket

Ordering information

ZML.1150.03

Drilling template for Blum distance bumper



- Template for bumper drilling on the unattached and attached front

Ordering information

ZML.1090



SERVO-DRIVE for box and runner systems/
SERVO-DRIVE uno

Assembly, adjustment and removal
blum.com/sdr9



For information about SERVO-DRIVE AVENTOS, go to:
blum.com/sdr10



Notes



SERVO-DRIVE flex

Electrical opening support system for handle-less built-in refrigerators

Overview

Drive unit

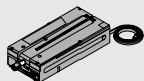

The drive unit triggers an ejection rod which opens the door. After the door is opened, the rod retracts automatically. In the event of unintentional opening, the drive unit closes the door again after 2.5, 4 or 8 seconds.

Rod cover cap



The rod cover cap seals the gap between the blind front and the rod. The gap ensures that the rod can eject the door and retract as required.

Blind front fixing

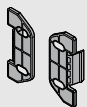

The blind front fixing connects the blind front to the mounting plate and makes assembly and removal easy.

Blum distance bumper



The Blum distance bumper ensures the required trigger path of 2 mm.

Catch plate



The catch plate serves as a locator for the magnetic rod in order to close the appliance door.

Cable end protector



The cable end protector is fitted onto the unused ends of the cable.

Cable holder

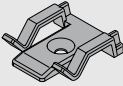

The cable holder allows you to route the SERVO-DRIVE distribution cable safely and neatly.

SERVO-DRIVE switch



The SERVO-DRIVE switch triggers the opening signal for the appliance door and enlarges the trigger range.

SERVO-DRIVE plug-in power supply unit

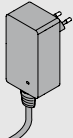

The SERVO-DRIVE plug-in power supply unit supplies power to a single drive unit (single application).

SERVO-DRIVE distribution cable

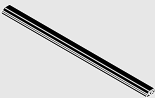

The distribution cable supplies power to the drive units. The max. permitted operating voltage is 24 V.

Note: This cable must not be directly connected to the mains power outlet.

Chipboard screws



The chipboard screws secure the drive unit, mounting plate and catch plate.

Connecting node

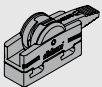

This node establishes the electrical connection between the SERVO-DRIVE distribution cable and the SERVO-DRIVE power supply unit.

Assembly jig



The assembly jig helps you attach the mounting plate correctly inside the cabinet.

Mounting plate



The mounting plate is screwed inside the cabinet and is used to attach the drive unit and blind front.

Power supply unit housing

Base fixing

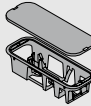

The power supply unit housing for base fixing securely accommodates the SERVO-DRIVE power supply unit on the base of the cabinet.

Power supply unit housing

Back panel/wall fixing

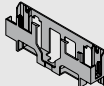

The SERVO-DRIVE power supply unit can be attached to the wall or back panel with the power supply unit housing for back panel/wall fixing.

SERVO-DRIVE power supply unit

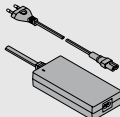

The SERVO-DRIVE power supply unit can be used around the world. It converts the country-specific mains voltage to 24 V direct current. You must use a flex with a regular plug for the respective country.

The SERVO-DRIVE power supply unit is used to supply several drive units with power (throughout the entire kitchen).

Colour/material			
GE	Yellow	NI	Nickel plated
SZ	Black	SW	Silk white
WS	White	K	Nylon
TGR	Dark grey	HGR	Light grey
WGR	White grey	R7037	RAL 7037 dust grey



SERVO-DRIVE flex
 Assembly, adjustment and removal
blum.com/sdr11

Recess height (NH) < 1700 mm



- Can be used for all standard built-in refrigerators and freezers
- Recess height (NH) < 1700 mm
- Low recess height (NH) for drive unit of min. 60 mm
- Adaptive system/automatic adjustment of the ejection force to the stay close force of the appliance door
- Automatic self-closing system for unintentional opening
- Lean protection feature
- Trigger safety
- Adjustable hold-open time (2,5 sec, 4 sec, 8 sec)
- Easy assembly thanks to feedback on correct installation depth via LED
- Not suitable for refrigerators without their own cabinet, with self-opening, with child safety latch, with automatic self-closing system, appliances with freezer at the bottom (recess height (NH) ≥1700 mm) and refrigerated drawers

Ordering information

SERVO-DRIVE flex set			
	Colour	Material	
	TGR	K	Z10C500A.01
Consisting of:			
1x drive unit			
2x mounting plate			
2x blind front fixing			
1x rod cover cap			
1x catch plate			
2x Blum distance bumper			
1x connecting node			
1x cable end protector			
11x chipboard screws			
1x assembly jig			

Y > 600 mm

SERVO-DRIVE switch			
	Colour	Material	
	SW/HGR/TGR	K	23P5020

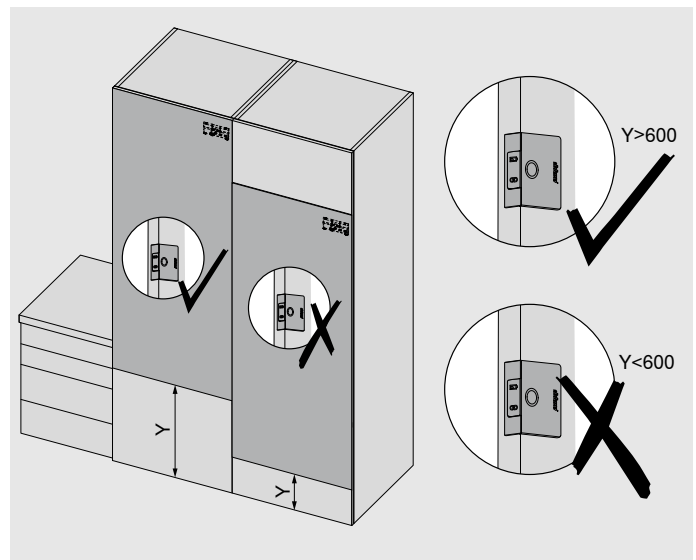

Recess height (NH) < 1700 mm

SERVO-DRIVE plug-in power supply unit

Only suitable for one drive unit

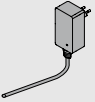

Market	Language package		Market	Language package	
E	A	☎ Z10NA40EA	E	F	☎ Z10NA40EF
E	B	☎ Z10NA40EB	B	A	☎ Z10NA40BA
E	C	☎ Z10NA40EC	K	I	☎ Z10NA40KI
E	D	☎ Z10NA40ED	N	H	☎ Z10NA40NH
E	E	☎ Z10NA40EE	U	G	☎ Z10NA40UG

☎ Item only available on request

Consisting of:

- 1 x SERVO-DRIVE plug-in power supply unit
Incl. cable, 1120 mm (with SERVO-DRIVE distribution cable extendible to max. 2000 mm)
Incl. operating and installation instructions

Markets and language packages

Code		Language packages*	
E	Europe	A	DE, EN, FR, IT, NL
B	GB	B	DA, EN, FI, NO, SV
K	AU	C	EL, EN, HR, SL, SR, TR
N	CN	D	EN, ES, FR, IT, PT
U	US CA JP	E	CS, HU, PL, SK
		F	BG, ET, LV, LT, RO, RU, GB
		G	EN, ES, FR
		H	EN, ZH, KO
		I	EN

* Language code according to the ISO 639 standard

Planning

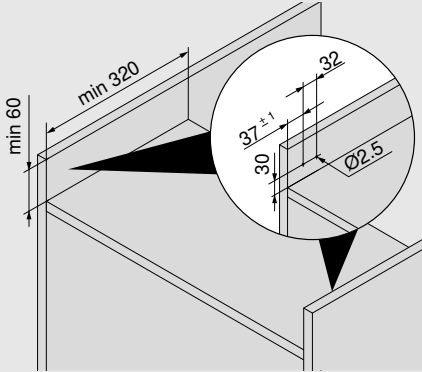
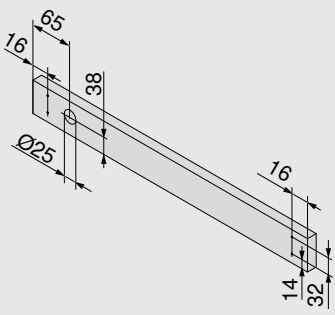
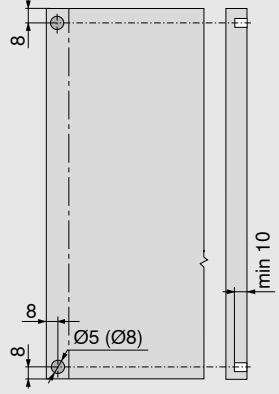
Mounting plate	Blind front – drive unit	Blum distance bumper
		 <p>Blum distance bumper is required for the refrigerator and freezer door</p> <p>The Blum distance bumper ensures the required trigger path of 2 mm</p>

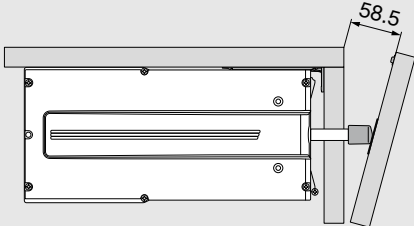
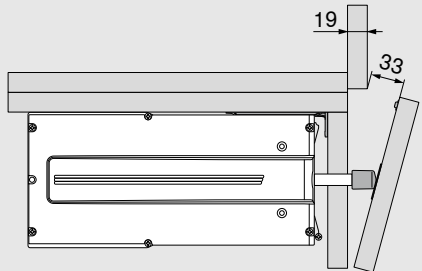
Access gap	SERVO-DRIVE switch
	 <p>Position in the worktop area</p>

Recess height (NH) ≥ 1700 mm



- Can be used for all standard built-in refrigerators and freezers
- Recess height (NH) ≥ 1700 mm
- Low recess height (NH) for drive unit of min. 60 mm
- Adaptive system/automatic adjustment of the ejection force to the stay close force of the appliance door
- Automatic self-closing system for unintentional opening
- Lean protection feature
- Trigger safety
- Adjustable hold-open time (2,5 sec, 4 sec, 8 sec)
- Easy assembly thanks to feedback on correct installation depth via LED and easy synchronisation of two drive units
- Not suitable for refrigerators without their own cabinet, with self-opening, with child safety latch, with automatic self-closing system, appliances with freezer at the bottom (recess height (NH) ≥ 1700 mm) and refrigerated drawers

Ordering information

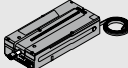
SERVO-DRIVE flex set			
	Colour	Material	
	TGR	K	2x Z10C500A.01
Consisting of:			
1x drive unit			
2x mounting plate			
2x blind front fixing			
1x rod cover cap			
1x catch plate			
2x Blum distance bumper			
1x connecting node			
1x cable end protector			
11x chipboard screws			
1x assembly jig			

Connecting node and cable end protector			
	Colour	Material	
	SZ	K	3x Z10V100E.01
Consisting of:			
1x connecting node			
2x cable end protectors			

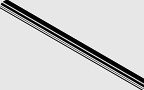
SERVO-DRIVE distribution cable			
	Colour	Material	
	SZ	K	
	Length 6000 mm		Z10K600A
For cutting to size			

Recess height (NH) ≥ 1700 mm

SERVO-DRIVE power supply unit incl. flex					
Markets	Language packages		Markets	Language packages	
E	A	Z10NE04EA	I	A	Z10NE04IA
E	B	Z10NE04EB	K	I	Z10NE04KI
E	C	Z10NE04EC	N	H	Z10NE04NH
E	D	Z10NE04ED	R	H	Z10NE04RH
E	E	Z10NE04EE	S	K	Z10NE04SK
E	F	Z10NE04EF	T	H	Z10NE04TH
E	I	Z10NE04EI	U	G	Z10NE04UG
B	A	Z10NE04BA	U	J	Z10NE04UJ
B	I	Z10NE04BI	Z	I	Z10NE04ZI
H	I	Z10NE04HI			
Incl. operating and installation instructions					
Consisting of:					
1 x	Power supply unit (output flex: length 2 m)				
1 x	Flex (1.5–1.8 m, incl. plug)				

Power supply unit housing			
	Base fixing		
	Colour	Material	
	TGR	K	Z10NG000
Incl. cover			
For SERVO-DRIVE power supply unit			

Alternative

Power supply unit housing			
	Back panel/wall fixing		
	Colour	Material	
	WGR	K	Z10NG120
For SERVO-DRIVE power supply unit			

Markets and language packages

Code			
Markets		Language packages*	
E	Europe	A	DE, EN, FR, IT, NL
B	GB	B	DA, EN, FI, NO, SV
H	IN	C	EL, EN, HR, SR, SL, TR
I	IL	D	EN, ES, FR, IT, PT
K	AU	E	CS, HU, PL, SK
N	CN	F	BG, ET, LV, LT, RO, RU, GB
R	KR	G	EN, ES, FR
S	BR	H	EN, ZH, KO
T	TW	I	EN
U	US CA JP	J	JA
Z	ZA	K	EN, ES, PT

* Language code according to the ISO 639 standard

Accessories

Cable holder			
	Colour	Material	
	WS	K	Z10K0009

Recess height (NH) ≥ 1700 mm

Planning

Mounting plate	Blind front – drive unit	Blum distance bumper
		<p>Blum distance bumper is required for the refrigerator and freezer door</p>
		<p>The Blum distance bumper ensures the required trigger path of 2 mm</p>

Access gap	

Space requirement and safety distance – power supply unit housing		
		<p>Please note</p> <p>Maintain a safety distance of 30 mm for air circulation. Otherwise there is a risk that the SERVO-DRIVE power supply unit could overheat. The dimensions in the drawing take the safety distance into account.</p>
<p>Base fixing</p>	<p>Back panel/wall fixing</p>	

Notes

Recess height (NH) ≥ 1700 mm



- Can be used for all standard built-in fridge/freezer combinations
- Recess height (NH) ≥ 1700 mm
- Low recess height (NH) for drive unit of min. 60 mm
- Adaptive system/automatic adjustment of the ejection force to the stay close force of the appliance door
- Automatic self-closing system for unintentional opening
- Lean protection feature
- Trigger safety
- Adjustable hold-open time (2,5 sec, 4 sec, 8 sec)
- Easy assembly thanks to feedback on correct installation depth via LED
- Not suitable for refrigerators without their own cabinet, with self-opening, with child safety latch, with automatic self-closing system, fridge-freezers with ventilation, appliances with freezer at the bottom (recess height (NH) ≥ 1700 mm) and refrigerated drawers

Ordering information

SERVO-DRIVE flex set			
	Colour	Material	
	TGR	K	2x Z10C500A.01
Consisting of:			
1x drive unit			
2x mounting plate			
2x blind front fixing			
1x rod cover cap			
1x catch plate			
2x Blum distance bumper			
1x connecting node			
1x cable end protector			
11x chipboard screws			
1x assembly jig			

Power supply unit housing			
	Base fixing		
	Colour	Material	
	TGR	K	Z10NG000
Incl. cover			
For SERVO-DRIVE power supply unit			

Alternative

Power supply unit housing			
	Back panel/wall fixing		
	Colour	Material	
	WGR	K	Z10NG120
For SERVO-DRIVE power supply unit			

Connecting node and cable end protector			
	Colour	Material	
	SZ	K	Z10V100E.01
Consisting of:			
1x connecting node			
2x cable end protectors			

SERVO-DRIVE distribution cable			
	Colour	Material	
	SZ	K	
	Length 6000 mm		Z10K600A
For cutting to size			

SERVO-DRIVE switch			
	Colour	Material	
	SW/HGR/TGR	K	23P5020

SERVO-DRIVE power supply unit incl. flex					
Markets	Language packages		Markets	Language packages	
E	A	Z10NE04EA	I	A	Z10NE04IA
E	B	Z10NE04EB	K	I	Z10NE04KI
E	C	Z10NE04EC	N	H	Z10NE04NH
E	D	Z10NE04ED	R	H	Z10NE04RH
E	E	Z10NE04EE	S	K	Z10NE04SK
E	F	Z10NE04EF	T	H	Z10NE04TH
E	I	Z10NE04EI	U	G	Z10NE04UG
B	A	Z10NE04BA	U	J	Z10NE04UJ
B	I	Z10NE04BI	Z	I	Z10NE04ZI
H	I	Z10NE04HI			
Incl. operating and installation instructions					
Consisting of:					
1 x	Power supply unit (output flex: length 2 m)				
1 x	Flex (1.5–1.8 m, incl. plug)				

Accessories

	Cable holder		Z10K0009
	Colour	Material	
	WS	K	

Markets and language packages

Code			
Markets		Language packages*	
E	Europe	A	DE, EN, FR, IT, NL
B	GB	B	DA, EN, FI, NO, SV
H	IN	C	EL, EN, HR, SR, SL, TR
I	IL	D	EN, ES, FR, IT, PT
K	AU	E	CS, HU, PL, SK
N	CN	F	BG, ET, LV, LT, RO, RU, GB
R	KR	G	EN, ES, FR
S	BR	H	EN, ZH, KO
T	TW	I	EN
U	US CA JP	J	JA
Z	ZA	K	EN, ES, PT

* Language code according to the ISO 639 standard

Planning

Mounting plate	Blind front – drive unit	Blum distance bumper
		<p>Blum distance bumper is required for the refrigerator and freezer door</p> <p>The Blum distance bumper ensures the required trigger path of 2 mm</p>

Access gap	SERVO-DRIVE switch
	<p>Position in the worktop area</p>



- For all standard built-in dishwashers
- Low recess height (NH) for drive unit of min. 60 mm
- Adaptive system/automatic adjustment of the ejection force to the stay close force of the appliance door
- Lean protection feature
- Trigger safety
- Adjustable hold-open time (2.5 sec, 4 sec, 8 sec)
- Easy assembly thanks to feedback on correct installation depth via LED
- Application possibilities depend on device type, worktop height and plinth height; see Planning
- Not suitable for dishwashers without their own cabinet, with self-opening, with child safety latch or with automatic self-closing system

Ordering information

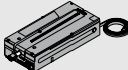
SERVO-DRIVE flex set			
			
Colour	Material		
TGR	K	Z10C500A.01	

Consisting of:

- 1x drive unit
- 2x mounting plate
- 2x blind front fixing
- 1x rod cover cap
- 1x catch plate
- 2x Blum distance bumper
- 1x connecting node
- 1x cable end protector
- 11x chipboard screws
- 1x assembly jig

Mounting plate			
			
Colour	Material		
TGR	K	Z10C5005	

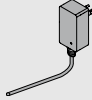
SERVO-DRIVE plug-in power supply unit					
Only suitable for one drive unit					
					
Market	Language package		Market	Language package	
E	A	☎ Z10NA40EA	E	F	☎ Z10NA40EF
E	B	☎ Z10NA40EB	B	A	☎ Z10NA40BA
E	C	☎ Z10NA40EC	K	I	☎ Z10NA40KI
E	D	☎ Z10NA40ED	N	H	☎ Z10NA40NH
E	E	☎ Z10NA40EE	U	G	☎ Z10NA40UG

☎ Item only available on request

Consisting of:	
1 x	SERVO-DRIVE plug-in power supply unit Incl. cable, 1120 mm (with SERVO-DRIVE distribution cable extendible to max. 2000 mm) Incl. operating and installation instructions

Markets and language packages

Code	
Markets	Language packages*
E Europe	A DE, EN, FR, IT, NL
B GB	B DA, EN, FI, NO, SV
K AU	C EL, EN, HR, SL, SR, TR
N CN	D EN, ES, FR, IT, PT
U US CA JP	E CS, HU, PL, SK
	F BG, ET, LV, LT, RO, RU, GB
	G EN, ES, FR
	H EN, ZH, KO
	I EN

* Language code according to the ISO 639 standard

Planning

Mounting plate

BD Blind front thickness
Max. 19 mm

Blind front – drive unit

SWD Cabinet side panel thickness

Drive unit

SWD Cabinet side panel thickness

Access gap

APÜ (mm)	ZS (mm)
0	30
20	10
30	0

APÜ Worktop protrusion
ZS Access gap

* The access gap ZS decreases with thicker fronts

Drilling template for the SERVO-DRIVE switch



- Simple hand-held tool for precision drilling of holes for the SERVO-DRIVE switch
- Hand drill required

Ordering information

M31.2000

Drilling template for Blum distance bumper, see page 65

A modern kitchen scene with a woman sitting on a stool at a kitchen island and a man cooking in the background. The kitchen features a long island with a wooden countertop and a man in a striped shirt cooking. A woman is sitting on a black stool at the island. The room has large windows, a dining table, and a herringbone wood floor.

moving ideas

You've got ideas, and so have we. Let's combine our creativity to turn good ideas into great ones. Inspiration moves us, and we excel at bringing it to life with our top quality, innovative products, designed to meet every requirement. We also offer comprehensive services and assembly devices to make life easier still. All this enables us to realise our goal of delivering quality and easy living in the home. Let's move ideas together.



Quality of living

Our mission is to deliver beauty and convenience for a better quality of living.



Product range

Our extensive product range has everything you need to turn your ideas into reality.



Inspiration

We monitor global trends and innovate to create solutions for tomorrow.



Innovation

We keep moving forward and constantly develop new products and services for you.



Services

Our services are tailored to your needs with one simple goal: to make your life easier.



Quality

Quality is paramount, so we continuously strive to improve our products and services.



Trust

We take responsibility for partnerships, our employees, society and the environment.

It all started with Julius Blum and horseshoe studs in 1952. Today we develop and supply top quality furniture fittings to customers in over 120 countries around the world.

Blum U.K.
Mandeville Drive
Kingston, Milton Keynes
GB-Buckinghamshire MK10 0AW
Tel.: 01908 285700
Fax: 01908 285701
E-mail: info.uk@blum.com

Julius Blum GmbH
6973 Höchst, Austria
Tel.: +43 5578 705-0
Fax: +43 5578 705-44
E-mail: info@blum.com
www.blum.com

Our sites in Austria, Poland and China are certified to the international standards mentioned below.
Our site in the USA is certified to ISO 9001.
Our site in Brazil is certified to ISO 9001, ISO 14001 and ISO 45001.



The Blum logo, consisting of a stylized arrow pointing upwards and to the right, followed by the word 'blum' in a bold, lowercase, sans-serif font, with a registered trademark symbol (®) to the upper right.



Look for our
FSC™-certified
products

All content is copyrighted by Blum.
Subject to technical modifications and changes to the range without notice.
IDNR: 208.668.6 · EP-660/1 EN-GB/06.25