



AVENTOS HK-XS

Small fitting, great convenience

www.blum.com

 **blum**[®]



Small fitting – high quality

AVENTOS HK-XS is the compact fitting for small stay lifts in high and wall cabinets. Thanks to the narrow style, AVENTOS HK-XS offers a high level of design freedom.

 **blum**

Contents

- 4** Quality of motion
- 6** Wide range of applications
- 8** Assembly
- 10** TIP-ON for handle-less lift systems
- 11** AVENTOS programme
- 12** Ordering and planning information
- 18** Blum

High quality of motion – typical of AVENTOS

AVENTOS HK-XS proves itself with the familiar AVENTOS quality of motion. Stay lifts open and close with seemingly weightless movement. They close silently and effortlessly in combination with CLIP top BLUMOTION hinges.

 **blum**



High quality of motion

The variable stop allows the lift system to remain in any desired position and always within easy reach.



Numerous possibilities

Whether thick wooden fronts with wide or narrow aluminium frames, the fixing positions always remain the same. This allows different materials and front thicknesses to be easily integrated.



Proven Blum quality

The lift mechanism with a robust spring package is the core element of the compact fitting. The AVENTOS HK-XS proves itself in this way with high stability and durability. High quality is ensured for the lifetime of the furniture.



A wide range of applications in every living area

The compact design of the AVENTOS HK-XS means that cabinets with small internal depths can be equipped easily. The symmetrical lift mechanism can be used on one or both sides. For the widest range of applications and a high level of design freedom.

 blum®



Wide folding fronts

If the lift mechanism is utilised on both sides, large, heavy fronts can also be used.



Above the extractor

Thanks to the small installation depth, it is possible with AVENTOS HK-XS to make optimal use of the space above the extractor, for example.



In the mirror cabinet

Wall cabinets with small internal depths are also ideal for use in the bathroom, for example over the sink. This has the advantage that storage items are well organised and always close to hand.





Cabinet fixing

There are various fixing methods available for fixing the lift mechanism to the cabinet. The fixing positions always remain the same, regardless of the thickness and material of the front.



Front fixing bracket

Fixing brackets are available for wooden fronts and for wide or narrow aluminium frames.



CLIP mechanism

The lift mechanism can be assembled tool-free using the CLIP mechanism.



Easy assembly

AVENTOS HK-XS can be assembled virtually tool-free. The infinitely variable adjustment is carried out from the front using the adjustment screw. Calibration helps to ensure the front is balanced. This guarantees the front will stop in any desired position.



> View assembly video
www.blum.com/Z3VmS

 **blum**

TIP-ON for handle-less stay lifts

Handle-less furniture has become an increasingly popular fixed element of modern furniture design. TIP-ON, the mechanical opening system, makes opening easy and convenient – also compatible with AVENTOS HK-XS.

 blum®



Easy opening

A single touch on the front releases the lift system so that you can open it upwards with ease.



Three colour variants

The TIP-ON unit is available in platinum grey, silk white and terra black. This allows it to be integrated discreetly into the cabinet or to create contrasts in colour.



Integrated front gap adjustment

The front gap adjustment is integrated in all versions and can also be used with drilled in TIP-ON. The front gap can be made larger or smaller by simply turning the ejector.

AVENTOS – An inspiring range of lift systems

AVENTOS lift systems ensure high quality of motion. Whether in the kitchen or another living area, for small fronts or large, AVENTOS ensures that lift systems can be opened with consummate ease. Freedom of movement is guaranteed throughout, and fronts are always out of the user's way.



BLUMOTION
inside

SERVO-DRIVE
inside

AVENTOS HF

Bi-fold lift system

- Ideal for high, bi-fold fronts in wall cabinets
- Low upward space requirement
- Can be used with fronts of different heights



BLUMOTION
inside

SERVO-DRIVE
inside

AVENTOS HS

Up & over lift system

- Ideal for large, one-part fronts in wall cabinets
- The lift system pivots over the cabinet
- Can also be combined with cornice or crown moulding



BLUMOTION
inside

SERVO-DRIVE
inside

AVENTOS HL

Lift up

- Ideal for large, one-part fronts in larders and wall cabinets
- Suitable for use with fronts above it
- Conceals electronic devices, for example, behind a continuous front



BLUMOTION
inside

SERVO-DRIVE
inside

TIP-ON
inside

AVENTOS HK

Stay lift

- Ideal for heavy fronts in wall cabinets
- Low upward space requirement
- Complete fitting



BLUMOTION
inside

TIP-ON
inside

AVENTOS HK-S

Small stay lift

- Ideal for small fronts in top wall cabinets
- Lift mechanism fits harmoniously into small cabinets, e.g. above the refrigerator or larder
- Complete fitting



BLUMOTION
inside

TIP-ON
inside

AVENTOS HK-XS

Small stay lift

- Ideal for small, top wall cabinets
- Also suitable for cabinets with low internal depths, e.g. above the extractor
- Small fitting, can be used on one or both sides

AVENTOS HK-XS



Order specification

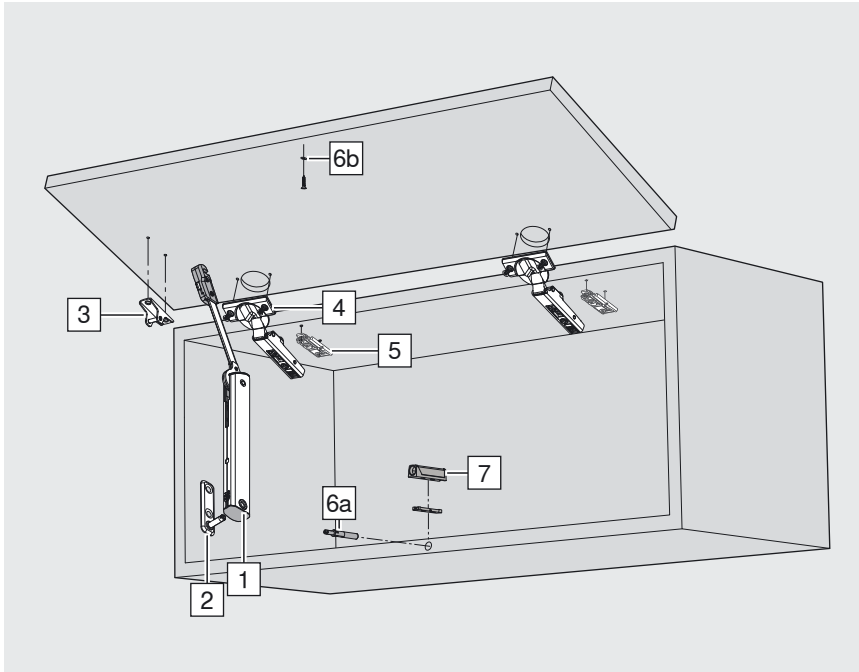

- Well suited for top wall cabinets
- Cabinet height from 240 mm to 600 mm
- Interior depth minimum 125 mm
- Closes silently and effortlessly in conjunction with CLIP top BLUMOTION hinges
- Can be combined with TIP-ON to open handle-less fronts
- Well-balanced quality of motion due to light operating forces, a variable stop and BLUMOTION
- Simple, virtually tool-free assembly and easy adjustment
- Symmetrical lift mechanism – can be used on one or both sides
- High-quality design



Power factor LF = cabinet height KH (mm) x door weight incl. double handle weight (kg)

Standard

TIP-ON

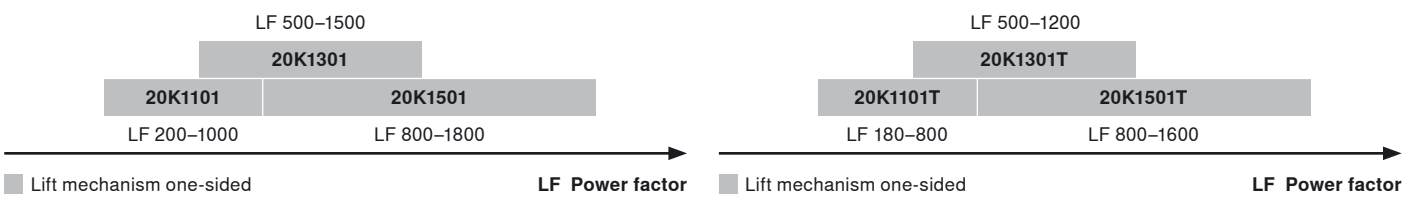

Note: the power factor is doubled when used on both sides.

A trial application is recommended when you are in a borderline area for the individual lift mechanism.

<input type="checkbox"/>	1	Symmetrical lift mechanism
	Power factor	
	200-1000	20K1101
	500-1500	20K1301
	800-1800	20K1501
	105° opening angle*	

<input checked="" type="checkbox"/>	1	Symmetrical lift mechanism
	Power factor	
	180-800	20K1101T
	500-1200	20K1301T
	800-1600	20K1501T
	105° opening angle*	

* For hinges with smaller opening angles, these are limited by the hinges.

2 Cabinet fixing			
	Nickel plated steel		
	Screws		20K5101
	EXPANDO		20K51E1

7 Horizontal adapter plate			
	Plastic, screws		
	SW, PG, TS ³⁾		
	Short version		
			956.1201

3 Front fixing bracket			
	Nickel plated steel		
	Screws ¹⁾		20K4101
	EXPANDO		20K41E1
	Narrow aluminium frames		20K4101A

Bit PZ cross slot			
	Size 2, length 39 mm		
			BIT-PZ KS2

Accessories CLIP top BLUMOTION 110°/CLIP top 110°

4 Hinge recommendation ²⁾				
	CLIP top BLUMOTION 110°			
	Screws	With spring	2x*	71B3550
	INSERTA	With spring	2x*	71B3590
	CLIP top 110° for TIP-ON			
	Screws	Unsprung	2x*	70T3550.TL
	INSERTA	Unsprung	2x*	70T3590.TL

Hinge arm cover cap			
	Print/Stamp		
	Plain		70.1503
	Stamped	Blum	70.1503.BP

Hinge boss cover cap			
	CLIP top BLUMOTION		70T3504
	CLIP top		70T3504

5 Mounting plate recommendation				
	Standard mounting plates, distance depends on the top gap			
	Fixing	Spacing		
	Screws	0 mm	2x*	175H3100
	EXPANDO	0 mm	2x*	177H3100E

Hinge boss spacing			
	1.5 mm		
	Screw-on		
	CLIP top BLUMOTION		70T3507.21

6 TIP-ON set				
	For drilling Ø 10 x 50 mm			
	Plastic			
	SW, PG, TS ³⁾			
	Short version, length 50 mm			956.1004
	Consisting of:			
6a	1 x TIP-ON			
6b	1 x screw-on catch plate ⁴⁾			
	1 x chipboard screw 609.1500			

Opening angle stop 86°			
	Plastic		
	Black		70T3553

Chipboard screws			
	Ø 3.5 x 15 mm		609.1500
	Ø 3.5 x 17 mm		609.1700

¹⁾ Use 2 chipboard screws (609.1x00) for wooden fronts. Use 2 countersunk self-tapping screws (660.0950) for wide aluminium frames.

²⁾ Alternatively, use the CLIP top BLUMOTION hinges, 95° profile door hinges, 95° aluminium frame hinges or the CLIP top hinges 107°, 110°, 95° profile door hinges, 95° aluminium frame hinges in combination with clip-on BLUMOTION 973A or unsprung (TIP ON). See Blum catalogue.

³⁾ SW silk white, PG platinum grey, TS terra black.

⁴⁾ Note: the glue-on catch plate should not be used in combination with TIP-ON for AVENTOS HK-XS.

* Number of hinges, see front assembly

AVENTOS HK-XS



Planning

Cabinet positions for lift mechanism

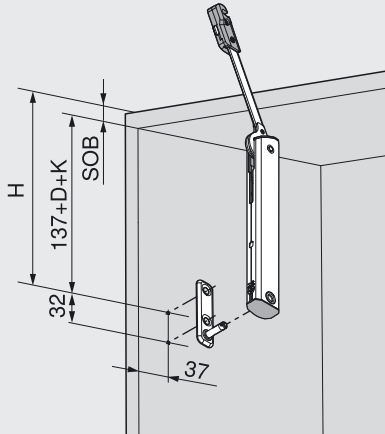

$$H = 137 + D + K + SOB$$

- D Mounting plate spacing
- K Hinge crank
 - Horizontal hinge arm 0 mm
 - Cranked hinge arm 9.5 mm
 - Double cranked hinge arm 18 mm
- SOB Top panel thickness

Space requirement

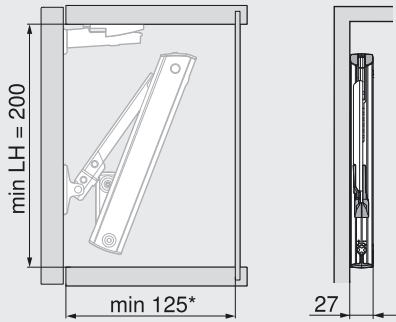

- LH Internal cabinet height
- * min. 200 mm with visible wall hanging bracket

Space requirement

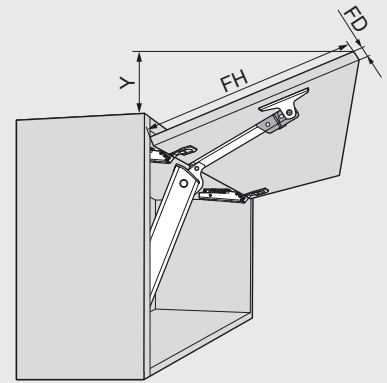

$$Y = (FH - a) \times 0.3$$

FD (mm)	16	19	22	24
a (mm)	45	34	23	15

- FD Front thickness
- FH Front height

Front assembly

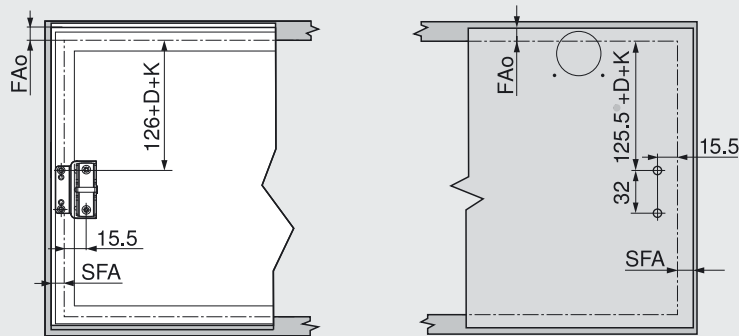

Narrow aluminium frames Wooden fronts and wide aluminium frames¹⁾

Wall application: Requires 5 mm minimum side gap

Ø 3.5 x 15 mm

FAo Upper front overlay

SFA Side front overlay

Number of hinges

- 3 hinges starting at cabinet width 900 mm and/or power factor 1800
- 4 hinges starting at cabinet width 1200 mm and/or power factor 2700

¹⁾ Use 2 chipboard screws (609.1x00) for wooden fronts. Use 2 countersunk self-tapping screws (660.0950) for wide aluminium frames.

Planning for narrow aluminium frames

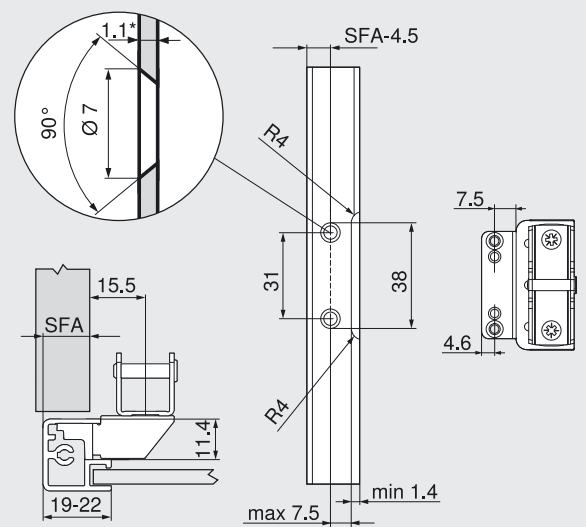

For frame frieze width 19 mm: SFA of 11–18 mm possible

SFA Side front overlay

R Radius

* When changing material thickness, adjust the assembly dimensions accordingly.

Cornice and crown moulding clearance

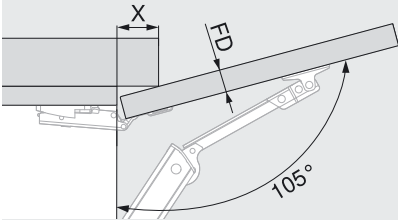

FD (mm)	16	19	22	24
X (mm)	45	34	23	15
FD	Front thickness			

Minimum gap

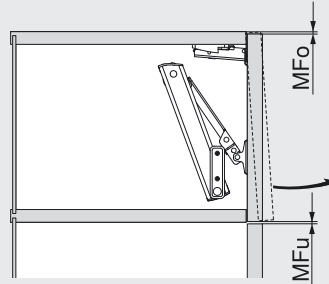

MFu Minimum gap at the bottom (1.5 mm)
 MFo Minimum gap at the top depending on hinge used – see Blum catalogue

CLIP top BLUMOTION 110°/
 CLIP top 110°

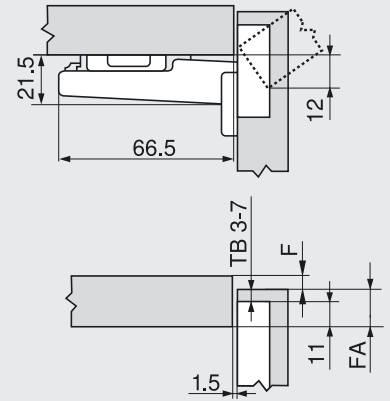

F Gap
 FA Front overlay
 TB Drilling distance

Minimum gap (F) for fronts with a front radius (R = 1 mm)
 based on the factory setting for CLIP top BLUMOTION 110°/ CLIP top 110°

		Front thickness FD											A trial application is recommended
		16	18	19	20	21	22	23	24	25	26	28	
 Drilling distance TB	3	0.5	0.8	1.0	1.2	1.5	1.8	2.2	2.7	3.5	4.3		
	4	0.5	0.8	1.0	1.2	1.4	1.7	2.0	2.5	3.1	3.8		
	5	0.5	0.8	0.9	1.2	1.4	1.7	2.0	2.4	2.9	3.4		
	6	0.5	0.8	0.9	1.2	1.3	1.6	1.9	2.3	2.7	3.2		
	7	0.5	0.8	0.9	1.1	1.3	1.6	1.9	2.2	2.6	3.0		
		Additional for + 2 mm side adjustment											
		+0.2	+0.4	+0.4	+0.5	+0.5	+0.5	+0.5	+0.5	+0.5	+0.5		

CLIP top BLUMOTION 110°/CLIP top 110°

Drilling distance TB

		Front overlay FA																	
		5	6	7	8	9	10	11	12	13	14	15	16	17	18				
0											3	4	5	6	7				
3									3	4	5	6	7						
6				3	4	5	6	7											
9	3	4	5	6	7														
		Mounting plate																	

Fixing position

TIP-ON short version

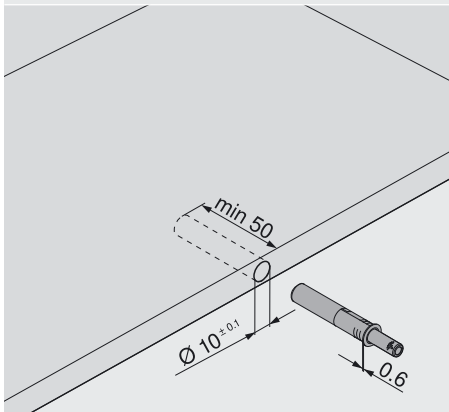

Horizontal adapter plate short

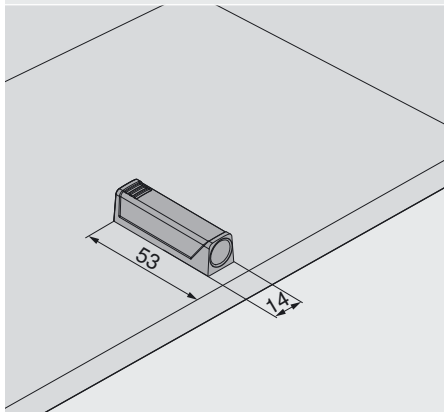

Installation dimensions

TIP-ON short version

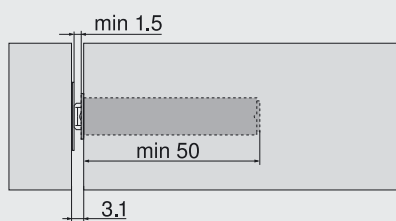

Horizontal adapter plate short

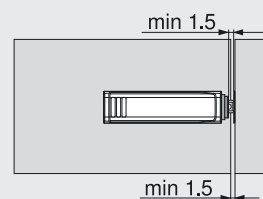
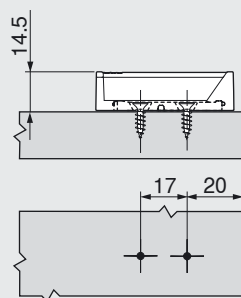

Factory setting = 2 mm

Screw-on catch plate planning

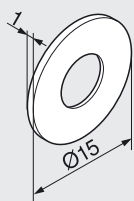

For drilling

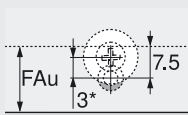

Horizontal adapter plate

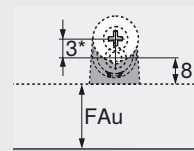

FAu Lower front overlay

* We recommend offsetting the positioning of TIP-ON by 3 mm for the screw-on catch plate.

Note: the glue-on catch plate should not be used in combination with TIP-ON for AVENTOS HK-XS.

Front assembly

Front fixing bracket

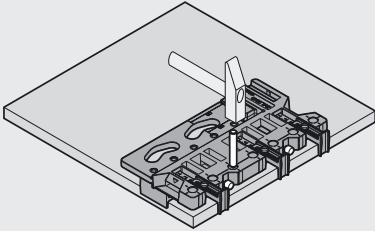

Universal drilling template

ZML.0040

Hinges

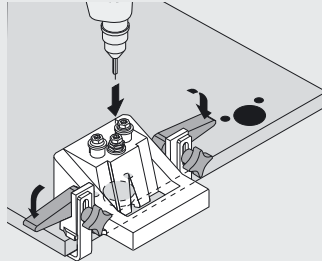

ECODRILL

M31.1000

Hinges

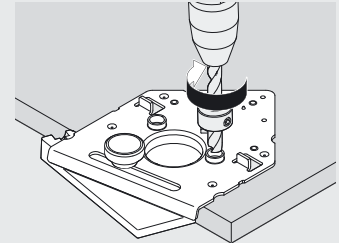

Drilling template for hinges

Ø 8 mm / Ø 2.5 mm

65.059A

Drilling template for hinges

Ø 2.5 mm

65.055A

Cabinet assembly

Cabinet assembly

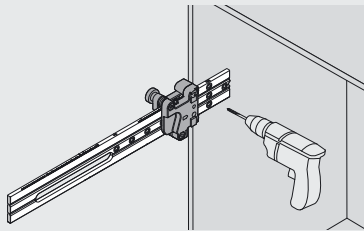

Universal-single template

65.1051.02

Mounting plate

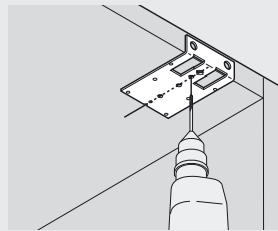

Template

65.5300

Can also be used for cabinet fixing

TIP-ON assembly

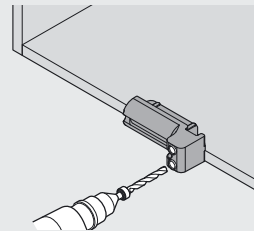

TIP-ON drilling template

For drilling

65.5010

Can also be used for TIP-ON for AVENTOS

Blum

Blum was founded by Julius Blum more than 60 years ago and is a family-owned company that operates on an international scale. Its strategic business segments include hinge, pull-out and lift systems. All our product developments focus on perfecting motion.

www.blum.com





Blum in Austria and around the world

Blum has seven plants in Vorarlberg, Austria as well as further production sites in Poland, the USA and Brazil and 27 subsidiaries and/or representative offices. The company supplies more than 100 markets. The Blum Group employs 6.100 people in total, 4.650 of whom work in Vorarlberg.



Global customer benefits

Whether manufacturer, distributor, fitter or kitchen user – everybody should personally enjoy the benefits of Blum products – that is Blum's philosophy on global customer benefits.



Innovations

To support customers with innovative fittings solutions and secure long-term success for the company, we need to consistently invest in research and development, in plants and facilities and in employee training. With more than 1.200 registered trademarks around the world, Blum is one of Austria's most innovative companies.



Quality

Blum's concept of quality is comprehensive and does not only apply to its products. Services and cooperation with customers and partners must meet the same high quality standards.



Environment

At Blum, we believe that responsible ecological behaviour has long-term economic benefits. The longevity of products is just one of many important aspects. Further important measures include the use of environmentally-friendly processes, the intelligent use of materials and prudent energy management.



DYNAMIC SPACE

Good workflows, sufficient storage space and top quality motion are important features of a practical kitchen. Blum's ideas for practical kitchens are designed to bring function, convenience and ergonomics to furniture interiors.



Blum U.K.
Mandeville Drive
Kingston, Milton Keynes
GB-Buckinghamshire MK10 0AW
Tel.: 01908 285700
Fax: 01908 285701
E-mail: info.uk@blum.com

Julius Blum GmbH
Furniture Fittings Mfg.
6973 Höchst, Austria
Tel.: +43 5578 705-0
Fax: +43 5578 705-44
E-mail: info@blum.com
www.blum.com

