



▶ TANDEMBOX antaro

The minimalist line – rectangular with a clear design all the way down the line



TANDEMBOX antaro has a clear, rectangular style – either with a gallery or as a closed box with a design element. All the components are colour-coordinated, thus accentuating the minimalist product design.

You also have the option of using the different opening support systems. SERVO-DRIVE, the electrical opening support system in combination with BLUMOTION, or TIP-ON, the mechanical opening support system.



Characteristic of the minimalist product design: the rectangular gallery

Design elements don't just provide closed containers but also give your kitchen character. Choose from Blum design elements made from glass or metal. Other materials are also possible, such as wood



All nylon components are matched with the relevant drawer side colour

The coordinated colour and material programme includes three steel variants: silk white, grey (white aluminium, RAL 9006) and terra black as well as stainless steel (Inox)



▶ TANDEMBOX antaro



Symbol image

▶▶ Overview – applications	264
----------------------------	-----

a ▶▶ Accessories



Symbol image

Design element	300	Centre bit	304
Steel back	301	Door buffer	304
Back fixing B height	301	Screwdriver	305
Flexible gallery fixing	302		
Side stabilisation – top mounted	303		
Front stabilisation	303		
Screws	304		

i ▶▶ Cabinet profile fixing positions

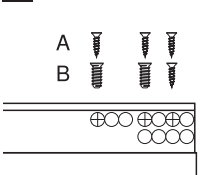

Symbol image

Cabinet profile 558B – 30 kg	306
Cabinet profile 559B – 50 kg	306
Cabinet profile 556B – 65 kg	306
Cabinet profile 559T – 20/30/50 kg	306
Side stabilisation – top mounted	307

i ▶▶ Assembly, removal and adjustment

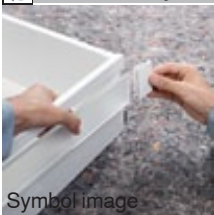

Symbol image

Drawer	308	Sink cabinet	313
Adjustment	308		
Inner drawer	309		
High fronted pull-out	310		
High fronted pull-out – design element	310		
Inner pull-out	311		
High fronted pull-out – alu frames	312		

i Pictograph

	Item Available Upon Request
i	General Information
a	Accessories
	TANDEMBOX antaro
	Corner cabinet
	Sink cabinet
	Larder unit
	Drawer
	Inner drawer
	High fronted pull-out
	Inner pull-out
	Gallery
D	Installation height and/or min. space requirement in cabinet

































	Height of Drawer Side
	Dynamic carrying capacity in kg
	Planning
	Cutting
	Assembly
	Assembly, removal and adjustment

Box systems

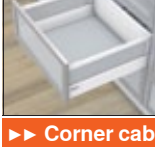

- ▶ TANDEMBOX antaro
- ▶▶ Overview – applications

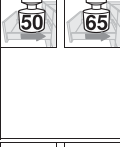
▶▶ Standard cabinet

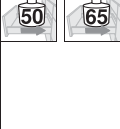
Drawer		Inner drawer	
	Drawer – N 266 		
	Drawer – M 268 		Inner drawer – M 270 
	Drawer – K 272 		Inner drawer – K 274 
High fronted pull-out		Inner pull-out	
	High fronted pull-out – gallery – C Design element possible 276 		Inner pull-out – gallery – C Design element possible 278 
	High fronted pull-out – gallery – D Design element possible 280 		Inner pull-out – gallery – D Design element possible 282 
	High fronted pull-out – gallery – D – K drawer side 284 		Inner pull-out – gallery – D – K drawer side 286 
	High fronted pull-out – gallery – C – alu frames Design element possible 288 		
	High fronted pull-out – gallery – D – alu frames Design element possible 290 		
▶▶ Corner cabinet			
	SPACE CORNER with SYNCROMOTION Design element possible 292		
	SPACE CORNER with rigid fronts Design element possible 293		



▶▶ Sink cabinet

High fronted pull-out			
	High fronted pull-out – gallery – C Design element possible	294	 30 50
	High fronted pull-out – gallery – D Design element possible	296	 30 50

▶▶ Larder unit

	SPACE TOWER Cabinet width 450 - 600 mm	298	
--	---	-----	--

a Accessories

	Glass design element	300	
	Metal design element	300	

i Info box

Take advantage of **DYNALOG limited** included free on the DVD.

- DYNAPLAN – cabinet planning incl. a collision check and fittings selection
- DYNACAT – electronic product catalogue and CAD data export (dxf, dwg, igs, sat, wrl, x_t, jpg)
- DYNASHOP – shopping basket and ordering function



Box systems

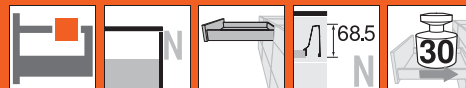

- ▶ TANDEMBOX antaro
- ▶▶ Standard cabinet

Drawer – N



- Concealed, guided full extension
- TANDEM inside – unsurpassed running action – for the lifetime of the furniture
- Drawer sides made from steel silk white (SW), terra black (TS), RAL 9006 grey (white aluminium, R9006) and stainless steel (Inox)
- Tool-free front assembly
- 2-dimensional front adjustment
- Includes integrated **BLUMOTION** for silent and effortless closing action, can be combined with **SERVO-DRIVE**
- Or with an integrated **TIP-ON** function for handle-less fronts

Space requirement

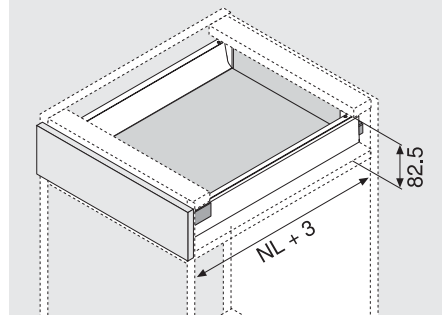

NL Nominal length

Order information

1	Cabinet profiles left/right	Cabinet profiles left/right	2	Drawer sides and cover caps left/right
	BLUMOTION *	TIP-ON **		SW TS R9006
Nominal length NL	30 kg	30/50 kg		
400 mm	558.4001B01	559.4001T	358N4002SA	358N4002IA
450 mm	558.4501B01	559.4501T	358N4502SA	358N4502IA
500 mm	558.5001B	559.5001T	358N5002SA	358N5002IA
550 mm	558.5501B	559.5501T	358N5502SA	358N5502IA

* Suitable for **SERVO-DRIVE**

** Order specification, see TIP-ON for TANDEMBOX

3	Back fixing left/right		
	Material	Colour	Part no.
	Steel	SW, TS, R9006, NI	Z30N000S.04

Colour			
SW	Silk white	S	Black
TS	Terra black	WGR	White grey
R9006	RAL 9006 grey (white aluminium)	R7037	RAL 7037 light grey
Inox	Stainless steel	NI	Nickel plated

4	Front fixing bracket		
	Fixing method		Part no.
	INSERTA	2 x	ZSF.3902
	Screw-on	2 x	ZSF.3502
	Knock-in	2 x	ZSF.3602

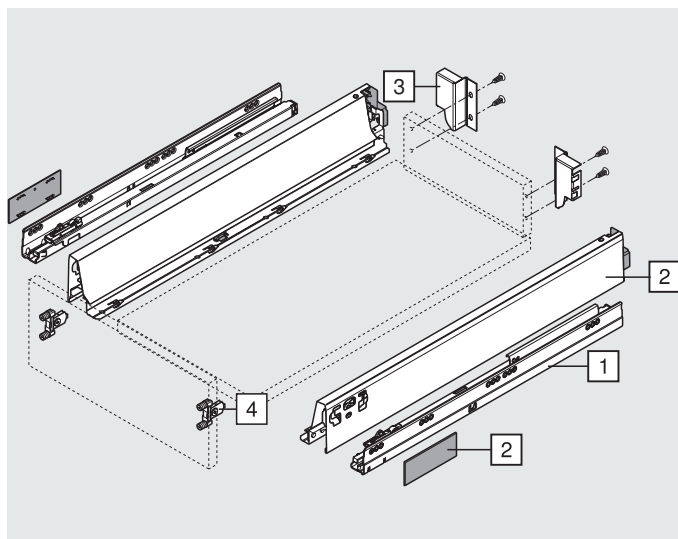

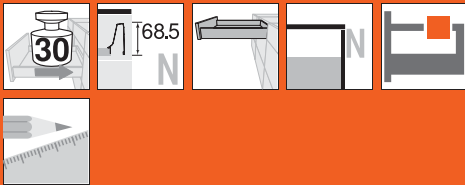

Drawer – N

Planning			
Space requirement in cabinet	Installation dimensions for screw-on front	Front drilling dimensions for INSERTA/knock-in	Back installation dimensions
	FA Front overlay 		

Cabinet profile screw positions

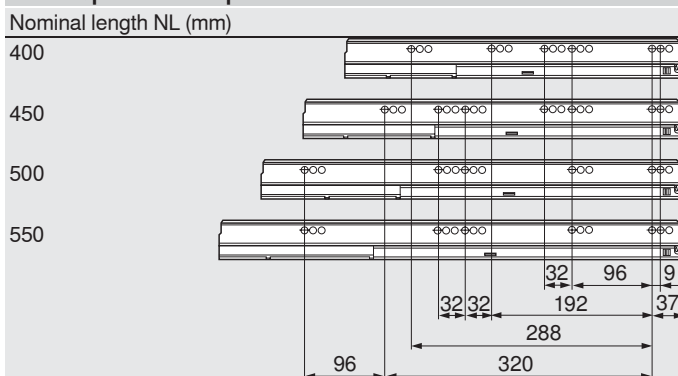

Cutting dimensions for 16 mm chipboard

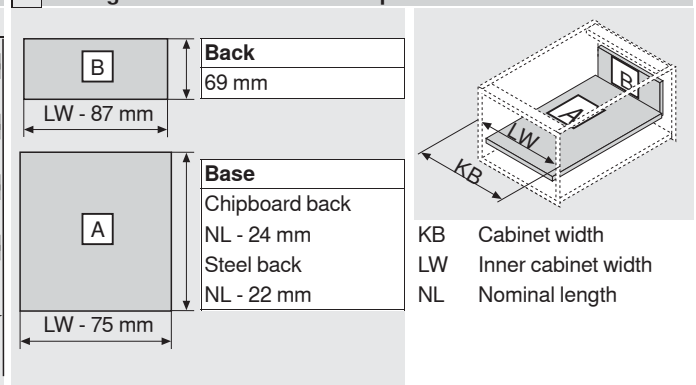

Min. internal cabinet depth = nominal length NL + 3 mm

Page instructions

Overview – TANDEMBOX antaro	263	More technical details	684
Overview – SERVO-DRIVE for TANDEMBOX	367		
Overview – TIP-ON for TANDEMBOX	407		
Accessories – steel back	301		
Accessories	300		
Cabinet profile fixing positions	306		
Assembly, removal and adjustment	308		
Overview – assembly devices	605		

Box systems

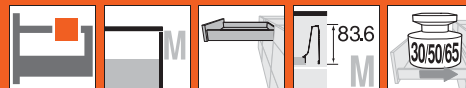

- ▶ TANDEMBOX antaro
- ▶▶ Standard cabinet

Drawer – M



- Concealed, guided full extension
- TANDEM inside – unsurpassed running action – for the lifetime of the furniture
- Drawer sides made from steel silk white (SW), terra black (TS), RAL 9006 grey (white aluminium, R9006) and stainless steel (Inox)
- Tool-free front assembly
- 2-dimensional front adjustment
- Includes integrated **BLUMOTION** for silent and effortless closing action, can be combined with **SERVO-DRIVE**
- Or with an integrated **TIP-ON** function for handle-less fronts

Space requirement

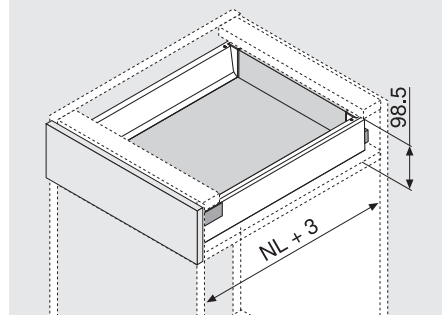

NL Nominal length

Order information

1	Cabinet profiles left/right			Cabinet profiles left/right	2	Drawer sides and cover caps left/right	
	BLUMOTION *					TIP-ON **	SW TS R9006
Nominal length NL	30 kg	50 kg	65 kg	20/30/50 kg			
270 mm	558.2701B			559.2701T	358M2702SA	358M2702IA	
300 mm	558.3001B			559.3001T	358M3002SA	358M3002IA	
350 mm	558.3501B01			559.3501T	358M3502SA	358M3502IA	
400 mm	558.4001B01			559.4001T	358M4002SA	358M4002IA	
450 mm	558.4501B01	559.4501B	556.4501B	559.4501T	358M4502SA	358M4502IA	
500 mm	558.5001B	559.5001B	556.5001B	559.5001T	358M5002SA	358M5002IA	
550 mm	558.5501B	559.5501B	556.5501B	559.5501T	358M5502SA	358M5502IA	
600 mm		559.6001B	556.6001B	559.6001T	359M6002SA	359M6002IA	
650 mm		559.6501B	556.6501B	559.6501T	359M6502SA	359M6502IA	

* Suitable for SERVO-DRIVE

** Order specification, see TIP-ON for TANDEMBOX

3	Back fixing left/right		
	Material	Colour	Part no.
	Steel	SW, TS, R9006, NI	Z30M000S.04

4	Front fixing bracket		
	Fixing method		Part no.
	INSERTA	2 x	ZSF.3902
	Screw-on	2 x	ZSF.3502
	Knock-in	2 x	ZSF.3602

Colour			
SW	Silk white	S	Black
TS	Terra black	WGR	White grey
R9006	RAL 9006 grey (white aluminium)	R7037	RAL 7037 light grey
Inox	Stainless steel	NI	Nickel plated

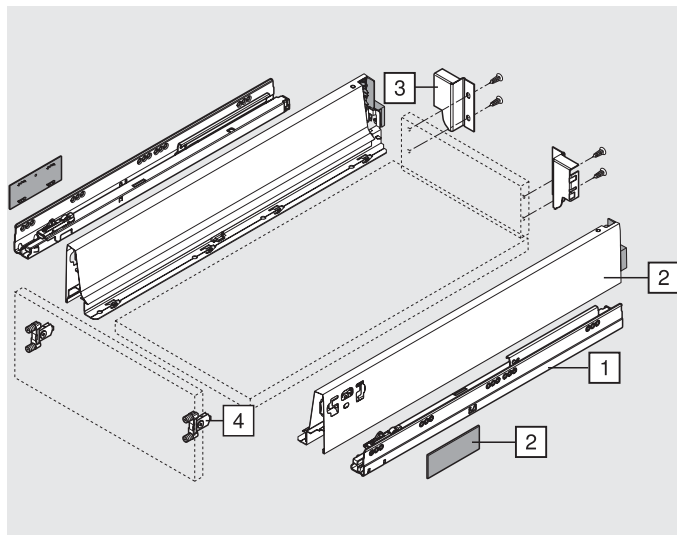

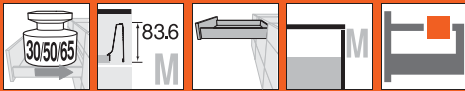

Drawer – M

Planning

Space requirement in cabinet	Installation dimensions for screw-on front	Front drilling dimensions for INSERTA/knock-in	Back installation dimensions
	FA Front overlay 		

Cabinet profile screw positions

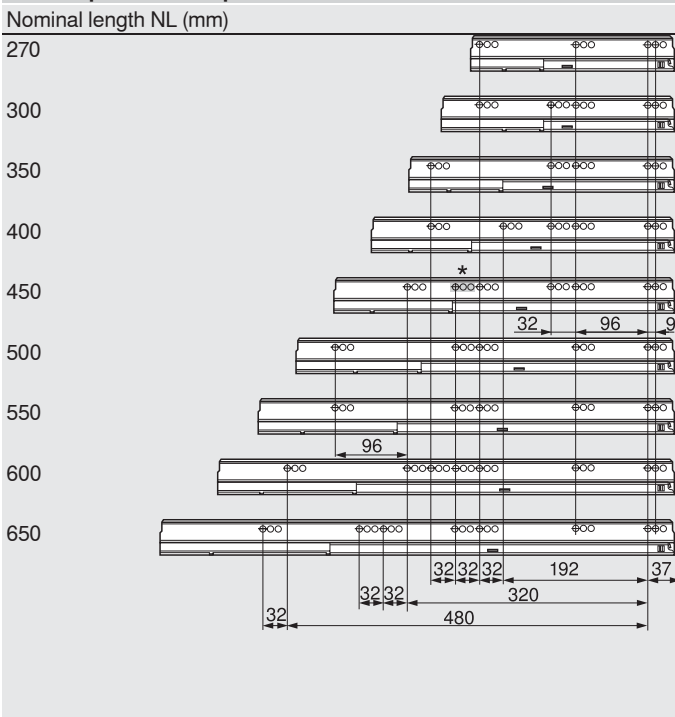

Min. internal cabinet depth = nominal length NL + 3 mm

* Only for 558.4501B01 (30 kg)

Cutting dimensions for 16 mm chipboard

	Back 84 mm	
	Base Chipboard back NL - 24 mm Steel back NL - 22 mm	

KB Cabinet width
LW Inner cabinet width
NL Nominal length

Page instructions

Overview – TANDEMBOX antaro	263	Assembly, removal and adjustment	308
Overview – SERVO-DRIVE for TANDEMBOX		Overview – assembly devices	605
	367	More technical details	684
Overview – TIP-ON for TANDEMBOX			
	407		
Overview – ORGA-LINE for TANDEMBOX			
	561		
Accessories – steel back			301
Accessories			300
Cabinet profile fixing positions			306

Box systems

- ▶ TANDEMBOX antaro
- ▶▶ Standard cabinet

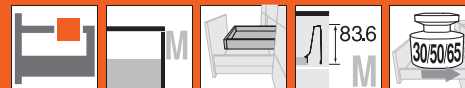

Inner drawer – M



- Concealed, guided full extension
- TANDEM inside – unsurpassed running action – for the lifetime of the furniture
- Drawer sides made from steel silk white (SW), terra black (TS), RAL 9006 grey (white aluminium, R9006) and stainless steel (Inox)
- Tool-free front assembly
- Includes integrated **BLUMOTION** for silent and effortless closing action, can be combined with **SERVO-DRIVE**
- Or with an integrated **TIP-ON** function for handle-less fronts
- Inner drawers either with handle or handle and latch

Space requirement

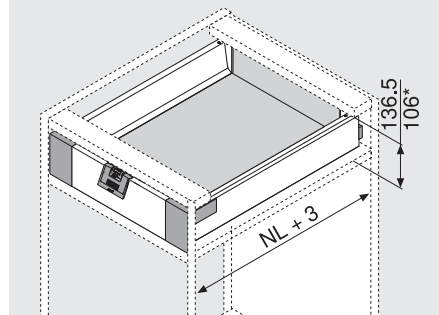

NL Nominal length
* With handle

Order information

1	Cabinet profiles left/right			Cabinet profiles left/right	2	Drawer sides and cover caps left/right	
	BLUMOTION *					TIP-ON **	SW TS R9006
Nominal length NL	30 kg	50 kg	65 kg	20/30/50 kg			
270 mm	558.2701B			559.2701T	358M2702SA	358M2702IA	
300 mm	558.3001B			559.3001T	358M3002SA	358M3002IA	
350 mm	558.3501B01			559.3501T	358M3502SA	358M3502IA	
400 mm	558.4001B01			559.4001T	358M4002SA	358M4002IA	
450 mm	558.4501B01	559.4501B	556.4501B	559.4501T	358M4502SA	358M4502IA	
500 mm	558.5001B	559.5001B	556.5001B	559.5001T	358M5002SA	358M5002IA	
550 mm	558.5501B	559.5501B	556.5501B	559.5501T	358M5502SA	358M5502IA	
600 mm		559.6001B	556.6001B	559.6001T	359M6002SA	359M6002IA	
650 mm		559.6501B	556.6501B	559.6501T	359M6502SA	359M6502IA	

* Suitable for **SERVO-DRIVE**

** Order specification, see TIP-ON for TANDEMBOX

3	Back fixing left/right		
	Material	Colour	Part no.
	Steel	SW, TS, R9006, NI	Z30M000S.04

4	Front fixing left/right		
	Material	Colour	Part no.
	Nylon	SW, S, WGR, R7037	ZIF.71M0
	Incl. locking piece Z31A0008		

5	Front piece without groove		
	Colour	Length	Part no.
	SW, TS, R9006, NI	For cutting to size, 1036 mm	Z31L1036A
	Cutting	Internal cabinet width LW - 132 mm	

a	Accessories		
6a	Handle		
	Material	Colour	Part no.
	Nylon	SW, S, WGR, R7037	ZIF.80M5

Alternative to 6a	Handle and latch		
6b	Material	Colour	Part no.
	Nylon	SW, S, WGR, R7037	ZIF.80M7

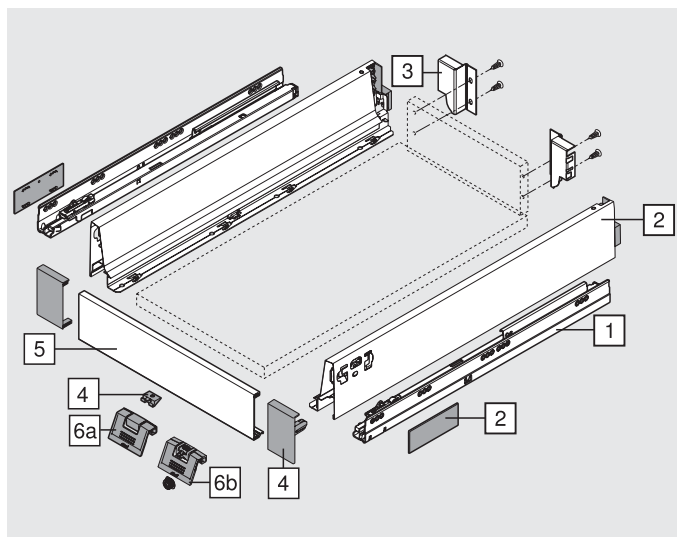

Colour			
SW	Silk white	S	Black
TS	Terra black	WGR	White grey
R9006	RAL 9006 grey (white aluminium)	R7037	RAL 7037 light grey
Inox	Stainless steel	NI	Nickel plated

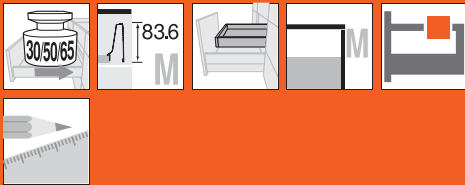

Inner drawer – M

Planning

Space requirement in cabinet

* A minimum space of 73 mm can be accommodated by using ZIF.80M5

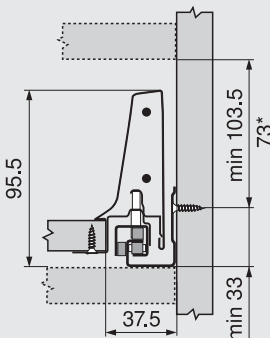

Back installation dimensions

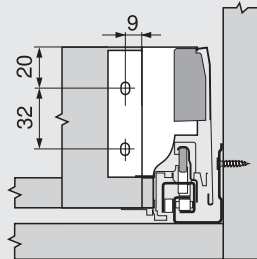

Front drilling dimensions for latch

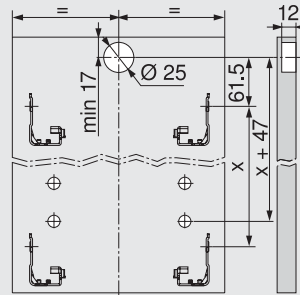

Cabinet profile screw positions

Nominal length NL (mm)

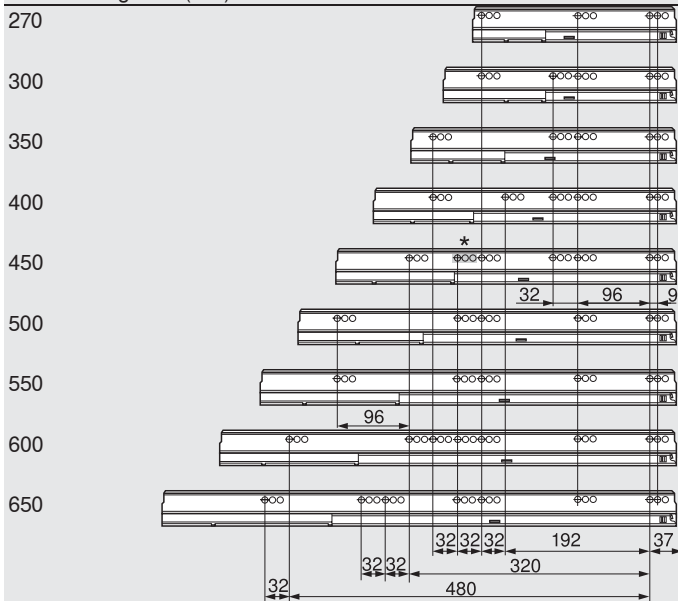

Min. internal cabinet depth = nominal length NL + 3 mm

* Only for 558.4501B01 (30 kg)

Cutting dimensions for 16 mm chipboard

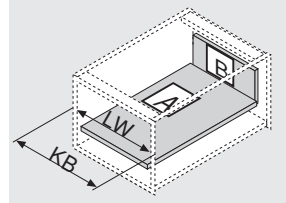
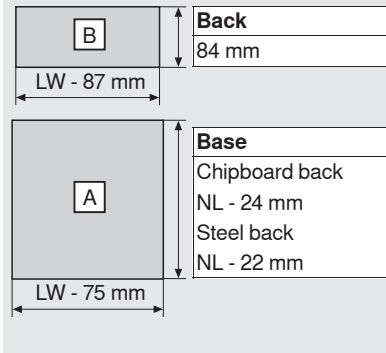

KB Cabinet width
LW Inner cabinet width
NL Nominal length

Page instructions

Overview – TANDEMBOX antaro	263	Assembly, removal and adjustment	308
Overview – SERVO-DRIVE for TANDEMBOX		Overview – assembly devices	605
	367	More technical details	684
Overview – TIP-ON for TANDEMBOX			
	407		
Overview – ORGA-LINE for TANDEMBOX			
	561		
Accessories – steel back	301		
Accessories	300		
Cabinet profile fixing positions	306		

Box systems

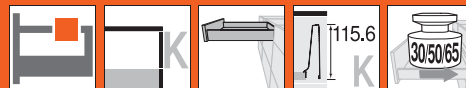

- ▶ TANDEMBOX antaro
- ▶▶ Standard cabinet

Drawer – K



- Concealed, guided full extension
- TANDEM inside – unsurpassed running action – for the lifetime of the furniture
- Drawer sides made from steel silk white (SW), terra black (TS), RAL 9006 grey (white aluminium, R9006)
- Tool-free front assembly
- 2-dimensional front adjustment
- Includes integrated **BLUMOTION** for silent and effortless closing action, can be combined with **SERVO-DRIVE**
- Or with an integrated **TIP-ON** function for handle-less fronts

Space requirement

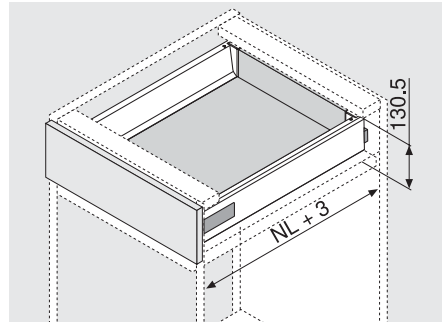

NL Nominal length

Order information

1	Cabinet profiles left/right			Cabinet profiles left/right	2	Drawer sides, cover caps and positioning dowels left/right		
	BLUMOTION *					TIP-ON **	Nominal length NL	SW
Nominal length NL	30 kg	50 kg	65 kg	20/30/50 kg	Nominal length NL	SW	TS	R9006
270 mm	558.2701B			559.2701T	270 mm	358K2702SA		
300 mm	558.3001B			559.3001T	300 mm	358K3002SA		
350 mm	558.3501B01			559.3501T	350 mm	358K3502SA		
400 mm	558.4001B01			559.4001T	400 mm	358K4002SA		
450 mm	558.4501B01	559.4501B	556.4501B	559.4501T	450 mm	358K4502SA		
500 mm	558.5001B	559.5001B	556.5001B	559.5001T	500 mm	358K5002SA		
550 mm	558.5501B	559.5501B	556.5501B	559.5501T	550 mm	358K5502SA		
600 mm		559.6001B	556.6001B	559.6001T	600 mm	359K6002SA		
650 mm		559.6501B	556.6501B	559.6501T	650 mm	359K6502SA		

* Suitable for **SERVO-DRIVE**

** Order specification, see TIP-ON for TANDEMBOX

3	Back fixing left/right		
Material	Colour	Part no.	
Steel	SW, TS, R9006	Z30K000S	

4	Front fixing bracket		
Fixing method	Part no.		
INSERTA	2 x	ZSF.3902	
Screw-on	2 x	ZSF.3502	
Knock-in	2 x	ZSF.3602	

Colour			
SW	Silk white	S	Black
TS	Terra black	WGR	White grey
R9006	RAL 9006 grey (white aluminium)	R7037	RAL 7037 light grey
Inox	Stainless steel	NI	Nickel plated

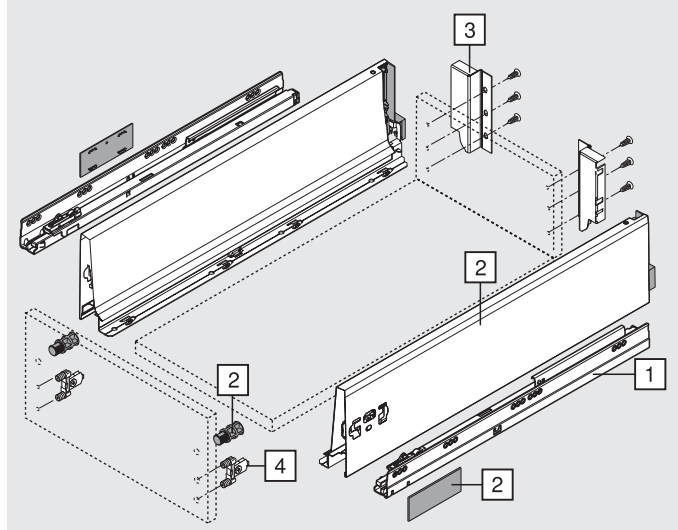

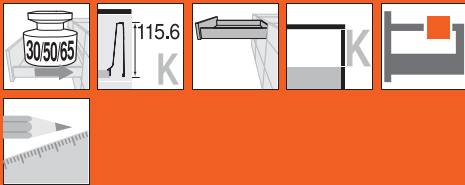

Drawer – K

Planning

Space requirement in cabinet	Installation dimensions for screw-on front	Front drilling dimensions for INSERTA/knock-in	Back installation dimensions
	<p>FA Front overlay</p>		

Cabinet profile screw positions

Nominal length NL (mm)	Screw positions
270	
300	
350	
400	
450	
500	
550	
600	
650	

Min. internal cabinet depth = nominal length NL + 3 mm

* Only for 558.4501B01 (30 kg)

Cutting dimensions for 16 mm chipboard

	<p>Back 116 mm</p>	
	<p>Base Chipboard back NL - 24 mm Steel back NL - 22 mm</p>	
		<p>KB Cabinet width LW Inner cabinet width NL Nominal length</p>

Page instructions

Overview – TANDEMBOX antaro	263	Assembly, removal and adjustment	308
Overview – SERVO-DRIVE for TANDEMBOX		Overview – assembly devices	605
	367	More technical details	684
Overview – TIP-ON for TANDEMBOX			
	407		
Overview – ORGA-LINE for TANDEMBOX			
	561		
Accessories – steel back	301		
Accessories	300		
Cabinet profile fixing positions	306		

Box systems

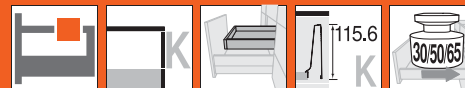

- ▶ TANDEMBOX antaro
- ▶▶ Standard cabinet

Inner drawer – K



- Concealed, guided full extension
- TANDEM inside – unsurpassed running action – for the lifetime of the furniture
- Drawer sides made from steel silk white (SW), terra black (TS), RAL 9006 grey (white aluminium, R9006)
- Tool-free front assembly
- Includes integrated **BLUMOTION** for silent and effortless closing action, can be combined with **SERVO-DRIVE**
- Or with an integrated **TIP-ON** function for handle-less fronts
- Inner drawers either with handle or handle and latch

Space requirement

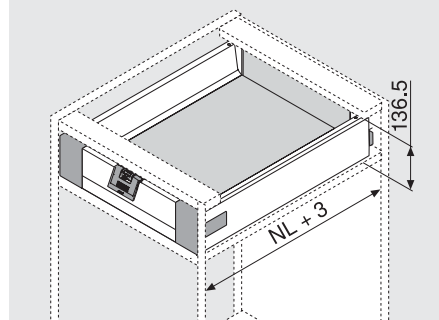

NL Nominal length

Order information

1	Cabinet profiles left/right			Cabinet profiles left/right	2	Drawer sides, cover caps and positioning dowels left/right		
	BLUMOTION *					TIP-ON **	Nominal length NL	SW
Nominal length NL	30 kg	50 kg	65 kg	20/30/50 kg	Nominal length NL	SW	TS	R9006
270 mm	558.2701B			559.2701T	270 mm			358K2702SA
300 mm	558.3001B			559.3001T	300 mm			358K3002SA
350 mm	558.3501B01			559.3501T	350 mm			358K3502SA
400 mm	558.4001B01			559.4001T	400 mm			358K4002SA
450 mm	558.4501B01	559.4501B	556.4501B	559.4501T	450 mm			358K4502SA
500 mm	558.5001B	559.5001B	556.5001B	559.5001T	500 mm			358K5002SA
550 mm	558.5501B	559.5501B	556.5501B	559.5501T	550 mm			358K5502SA
600 mm		559.6001B	556.6001B	559.6001T	600 mm			359K6002SA
650 mm		559.6501B	556.6501B	559.6501T	650 mm			359K6502SA

* Suitable for **SERVO-DRIVE**

** Order specification, see TIP-ON for TANDEMBOX

3	Back fixing left/right		
Material	Colour	Part no.	
Steel	SW, TS, R9006	Z30K000S	

4	Front fixing left/right		
Material	Colour	Part no.	
Nylon	SW, S, WGR	ZIF.71K0	
Incl. locking piece Z31A0008			

5	Front piece without groove		
Colour	Length	Part no.	
SW, TS, R9006	For cutting to size, 1036 mm	Z31L1036A	
Cutting		Internal cabinet width LW - 132 mm	

a	Accessories		
6a	Handle		
Material	Colour	Part no.	
Nylon	SW, S, WGR	ZIF.80M5	

Alternative to 6a			
6b	Handle and latch		
Material	Colour	Part no.	
Nylon	SW, S, WGR	ZIF.80M7	

Colour			
SW	Silk white	S	Black
TS	Terra black	WGR	White grey
R9006	RAL 9006 grey (white aluminium)	R7037	RAL 7037 light grey
Inox	Stainless steel	NI	Nickel plated

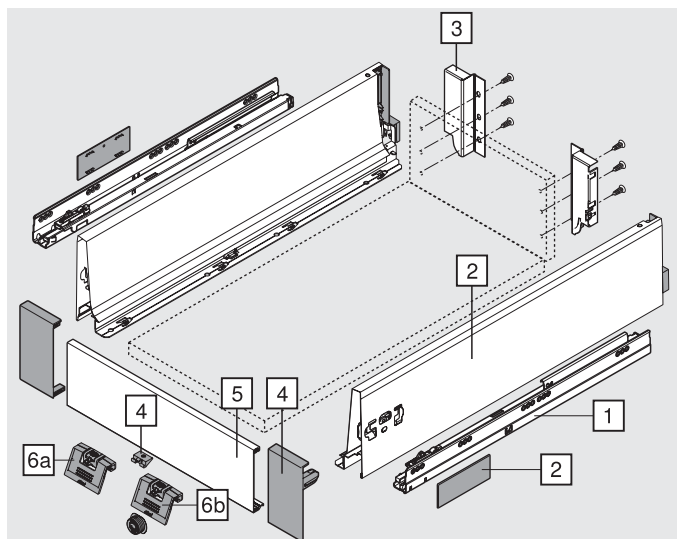

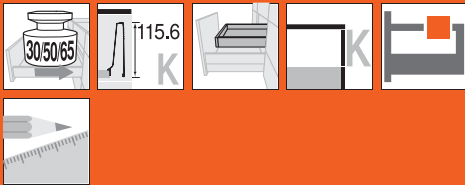

Inner drawer – K

Planning

Space requirement in cabinet	Back installation dimensions	Front drilling dimensions for latch

Cabinet profile screw positions

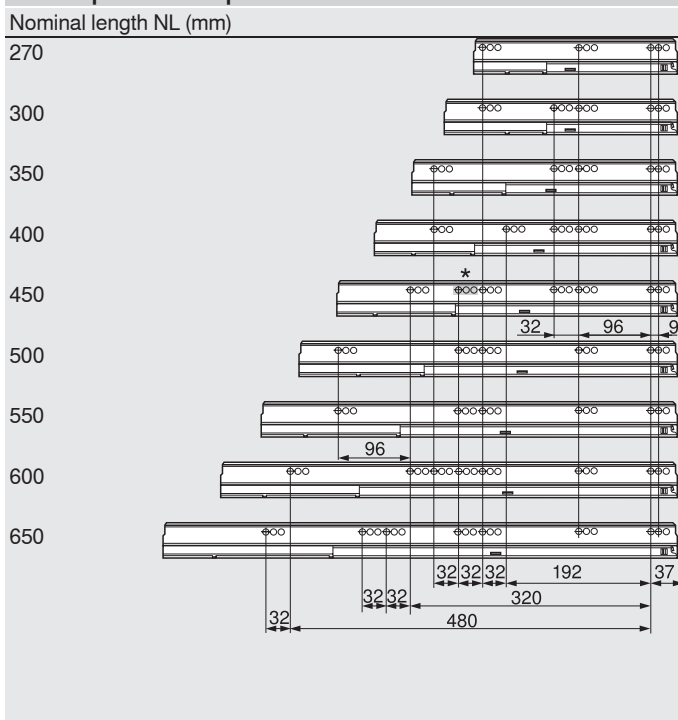

Min. internal cabinet depth = nominal length NL + 3 mm

* Only for 558.4501B01 (30 kg)

Cutting dimensions for 16 mm chipboard

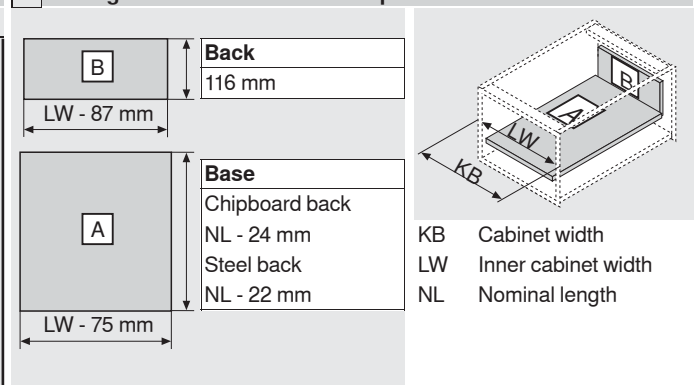

Page instructions

Overview – TANDEMBOX antaro	263	Assembly, removal and adjustment	308
Overview – SERVO-DRIVE for TANDEMBOX		Overview – assembly devices	605
	367	More technical details	684
Overview – TIP-ON for TANDEMBOX			
	407		
Overview – ORGA-LINE for TANDEMBOX			
	561		
Accessories – steel back	301		
Accessories	300		
Cabinet profile fixing positions	306		

Box systems

- ▶ TANDEMBOX antaro
- ▶▶ Standard cabinet



High fronted pull-out – gallery – C



- With simple gallery
- Design element possible
- Concealed, guided full extension
- TANDEM inside – unsurpassed running action – for the lifetime of the furniture
- Drawer sides made from steel silk white (SW), terra black (TS), RAL 9006 grey (white aluminium, R9006) and stainless steel (Inox)
- Tool-free front assembly
- 3-dimensional front adjustment
- Includes integrated **BLUMOTION** for silent and effortless closing action, can be combined with **SERVO-DRIVE**
- Or with an integrated **TIP-ON** function for handle-less fronts

Space requirement

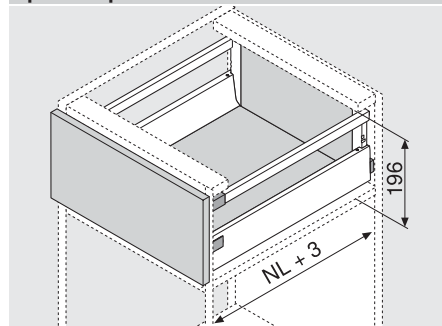

NL Nominal length

Order information

1	Cabinet profiles left/right			Cabinet profiles left/right	2	Drawer sides and cover caps left/right		8	Longside gallery rail left/right			
	BLUMOTION *					TIP-ON **	SW		TS R9006	Inox	SW	TS R9006
Nominal length NL	30 kg	50 kg	65 kg	20/30/50 kg	SW	TS	R9006	Inox	SW	TS	R9006	Inox
270 mm	558.2701B			559.2701T	358M2702SA	358M2702IA			ZRG.207RSIC	ZRG.207RIIC		
300 mm	558.3001B			559.3001T	358M3002SA	358M3002IA			ZRG.237RSIC	ZRG.237RIIC		
350 mm	558.3501B01			559.3501T	358M3502SA	358M3502IA			ZRG.287RSIC	ZRG.287RIIC		
400 mm	558.4001B01			559.4001T	358M4002SA	358M4002IA			ZRG.337RSIC	ZRG.337RIIC		
450 mm	558.4501B01	559.4501B	556.4501B	559.4501T	358M4502SA	358M4502IA			ZRG.387RSIC	ZRG.387RIIC		
500 mm	558.5001B	559.5001B	556.5001B	559.5001T	358M5002SA	358M5002IA			ZRG.437RSIC	ZRG.437RIIC		
550 mm	558.5501B	559.5501B	556.5501B	559.5501T	358M5502SA	358M5502IA			ZRG.487RSIC	ZRG.487RIIC		
600 mm		559.6001B	556.6001B	559.6001T	359M6002SA	359M6002IA			ZRG.537RSIC	ZRG.537RIIC		
650 mm		559.6501B	556.6501B	559.6501T	359M6502SA	359M6502IA			ZRG.587RSIC	ZRG.587RIIC		

* Suitable for SERVO-DRIVE

** Order specification, see TIP-ON for TANDEMBOX

3	Back fixing left/right		
Material	Colour	Part no.	
Steel	SW, TS, R9006, NI	Z30C000S	

4	Front fixing bracket		
Fixing method	Part no.		
INSERTA	2 x ZSF.3902		
Screw-on	2 x ZSF.3502		
Knock-in	2 x ZSF.3602		

a	Accessories		
9	Locking piece set		
Material	Colour	Part no.	
Nylon	SW, S, WGR, R7037	Z36C0080	

9a	Design element (side)		
Material	Colour	Part no.	
Glass	Clear, frosted	2 x Z37Rxx7C	
Metal	SW, TS, R9006	2 x Z37Axx7C	

Order specification, see accessories – design element

Colour			
SW	Silk white	S	Black
TS	Terra black	WGR	White grey
R9006	RAL 9006 grey (white aluminium)	R7037	RAL 7037 light grey
Inox	Stainless steel	NI	Nickel plated

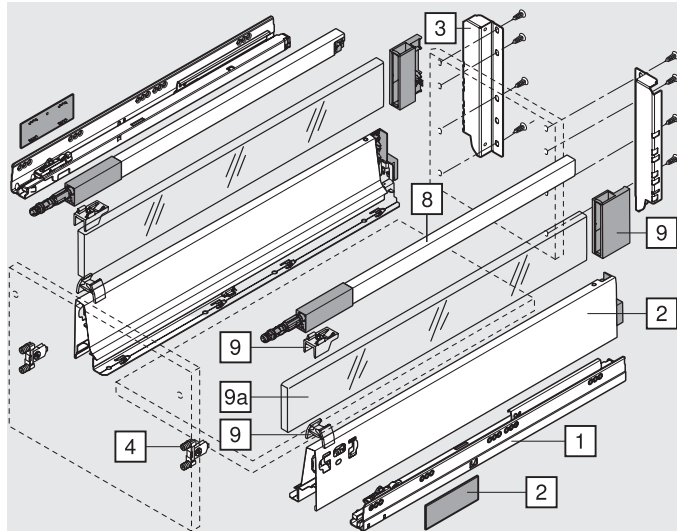



High fronted pull-out – gallery – C

Planning

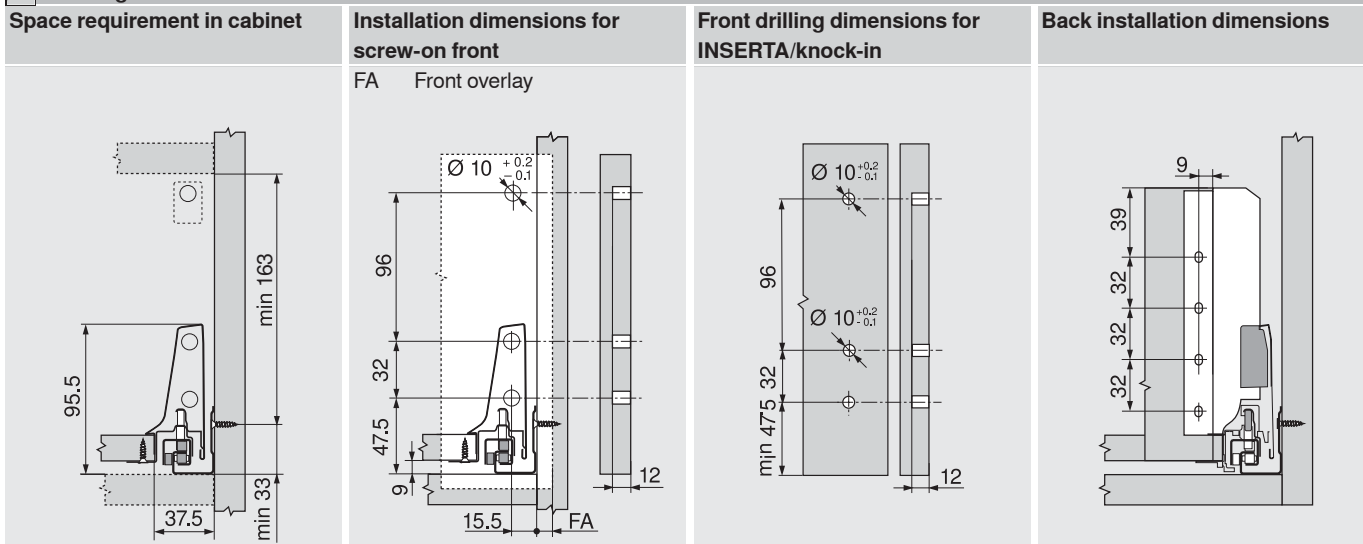

Cabinet profile screw positions

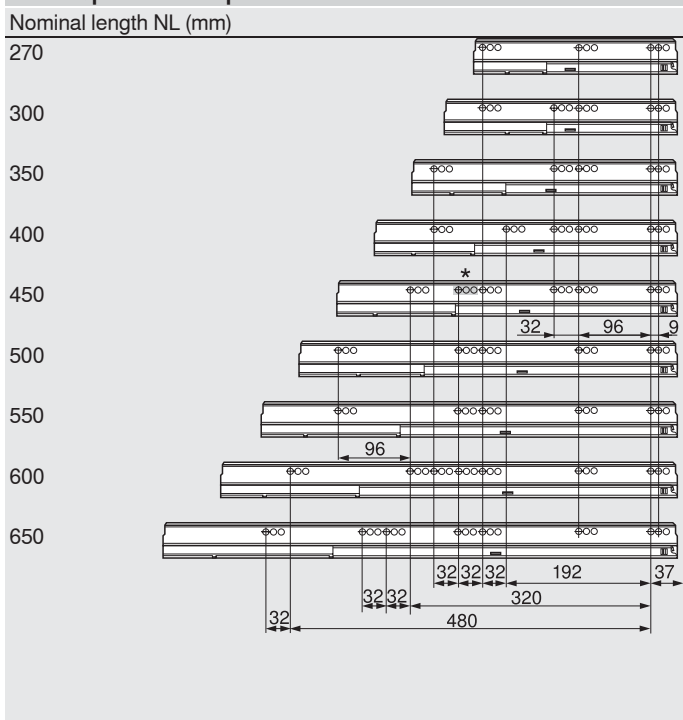

Cutting dimensions for 16 mm chipboard

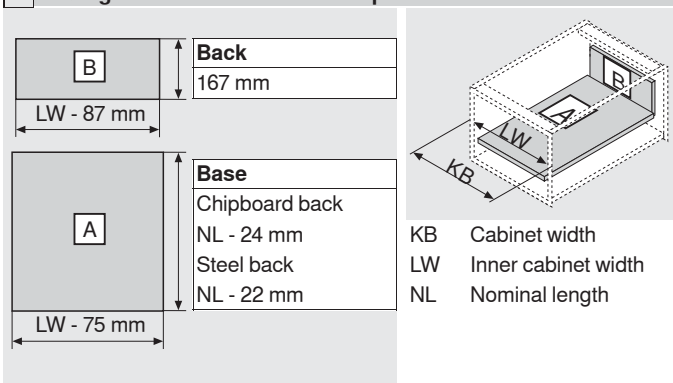

Cutting dimensions design element

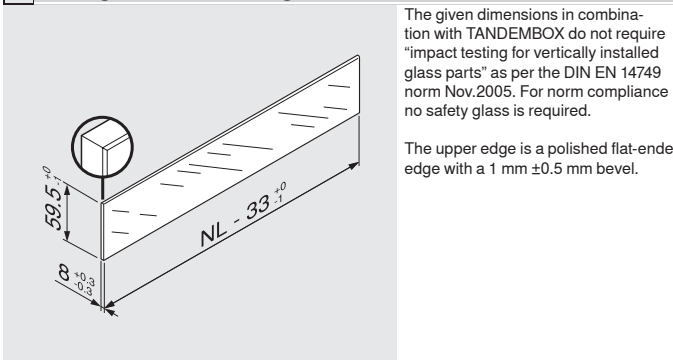

Page instructions

Overview – TANDEMBOX antaro	263	Cabinet profile fixing positions	306
Overview – SERVO-DRIVE for TANDEMBOX	367	Assembly, removal and adjustment	308
Overview – TIP-ON for TANDEMBOX	407	Overview – assembly devices	605
Overview – ORGA-LINE for TANDEMBOX	561	More technical details	684
Accessories – design element	300		
Accessories – steel back	301		
Accessories	300		

Box systems

- ▶ TANDEMBOX antaro
- ▶▶ Standard cabinet



Inner pull-out – gallery – C



- With simple gallery
- Design element possible
- Concealed, guided full extension
- TANDEM inside – unsurpassed running action – for the lifetime of the furniture
- Drawer sides made from steel silk white (SW), terra black (TS), RAL 9006 grey (white aluminium, R9006) and stainless steel (Inox)
- Tool-free front assembly
- 3-dimensional front adjustment
- Includes integrated **BLUMOTION** for silent and effortless closing action, can be combined with **SERVO-DRIVE**
- Or with an integrated **TIP-ON** function for handle-less fronts

Space requirement

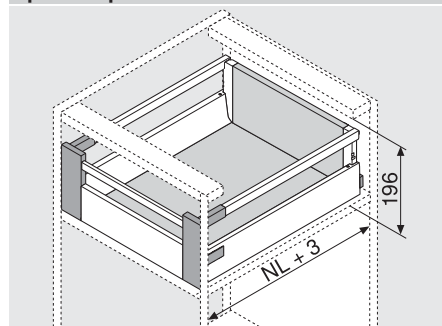

NL Nominal length

Order information

1	Cabinet profiles left/right			Cabinet profiles left/right	2	Drawer sides and cover caps left/right		8	Longside gallery rail left/right			
	BLUMOTION *					TIP-ON **	SW		TS R9006	Inox	SW	TS R9006
Nominal length NL	30 kg	50 kg	65 kg	20/30/50 kg	SW	TS	R9006	Inox	SW	TS	R9006	Inox
270 mm	558.2701B			559.2701T	358M2702SA	358M2702IA			ZRG.207RSIC	ZRG.207RIIC		
300 mm	558.3001B			559.3001T	358M3002SA	358M3002IA			ZRG.237RSIC	ZRG.237RIIC		
350 mm	558.3501B01			559.3501T	358M3502SA	358M3502IA			ZRG.287RSIC	ZRG.287RIIC		
400 mm	558.4001B01			559.4001T	358M4002SA	358M4002IA			ZRG.337RSIC	ZRG.337RIIC		
450 mm	558.4501B01	559.4501B	556.4501B	559.4501T	358M4502SA	358M4502IA			ZRG.387RSIC	ZRG.387RIIC		
500 mm	558.5001B	559.5001B	556.5001B	559.5001T	358M5002SA	358M5002IA			ZRG.437RSIC	ZRG.437RIIC		
550 mm	558.5501B	559.5501B	556.5501B	559.5501T	358M5502SA	358M5502IA			ZRG.487RSIC	ZRG.487RIIC		
600 mm		559.6001B	556.6001B	559.6001T	359M6002SA	359M6002IA			ZRG.537RSIC	ZRG.537RIIC		
650 mm		559.6501B	556.6501B	559.6501T	359M6502SA	359M6502IA			ZRG.587RSIC	ZRG.587RIIC		

* Suitable for **SERVO-DRIVE**

** Order specification, see TIP-ON for TANDEMBOX

3	Back fixing left/right		
Material	Colour	Part no.	
Steel	SW, TS, R9006, NI	Z30C000S	

4	Front fixing left/right		
Material	Colour	Part no.	
Nylon	SW, S, WGR, R7037	ZIF.74C0	
Incl. locking piece Z31A0008			
Incl. 2 x gallery head ZRG.000R5F			

5	Front piece without groove		
Colour	Length	Part no.	
SW, TS, R9006, NI	For cutting to size, 1036 mm	Z31L1036A	
Cutting		Internal cabinet width LW - 132 mm	

7	Cross gallery		
Colour	Length	Part no.	
SW, TS, R9006, NI	For cutting to size, 1046 mm	ZRG.1046Z	
Cutting		Internal cabinet width LW - 122 mm	

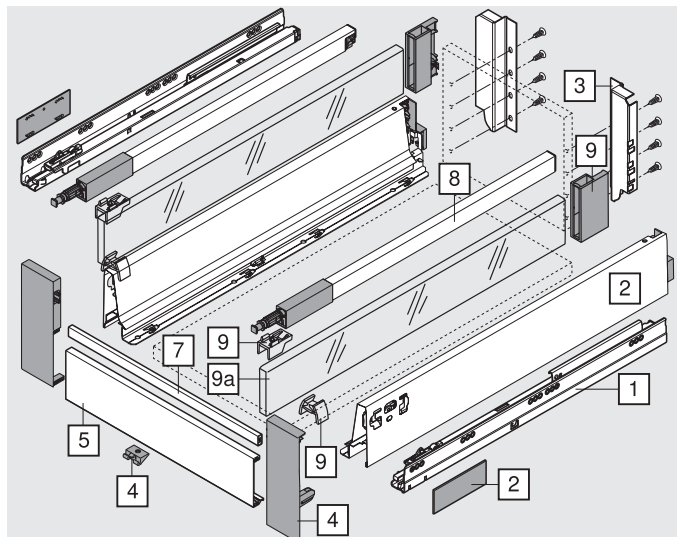

a	Accessories		
9	Locking piece set		
Material	Colour	Part no.	
Nylon	SW, S, WGR, R7037	Z36C0080	

9a	Design element (side)		
Material	Colour	Part no.	
Glass	Clear, frosted	2 x	Z37Rxx7C
Metal	SW, TS, R9006	2 x	Z37Axx7C

Order specification, see accessories – design element

Colour			
SW	Silk white	S	Black
TS	Terra black	WGR	White grey
R9006	RAL 9006 grey (white aluminium)	R7037	RAL 7037 light grey
Inox	Stainless steel	NI	Nickel plated



Inner pull-out – gallery – C

Planning

Space requirement in cabinet

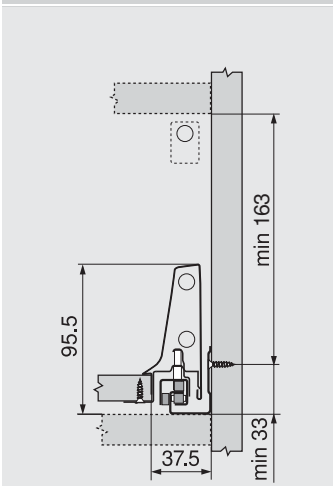

Back installation dimensions

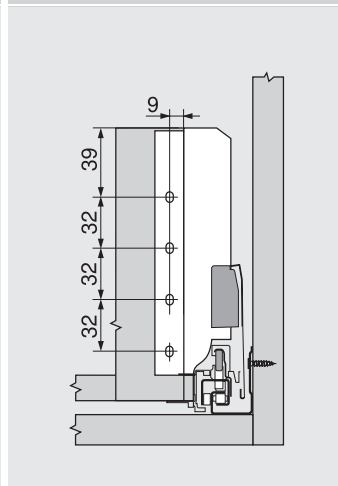

Cabinet profile screw positions

Nominal length NL (mm)

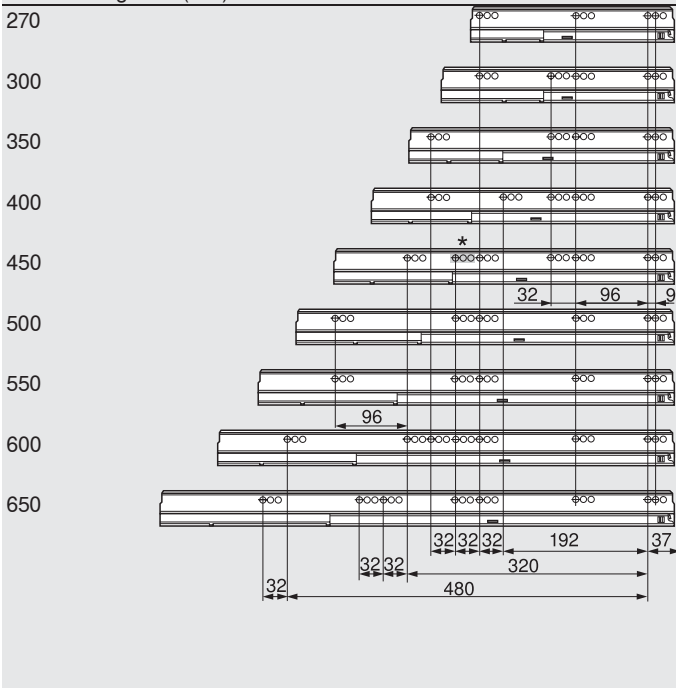

Min. internal cabinet depth = nominal length NL + 3 mm

* Only for 558.4501B01 (30 kg)

Cutting dimensions for 16 mm chipboard

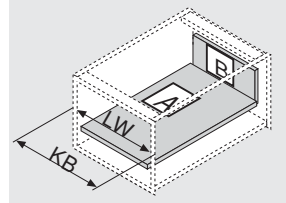
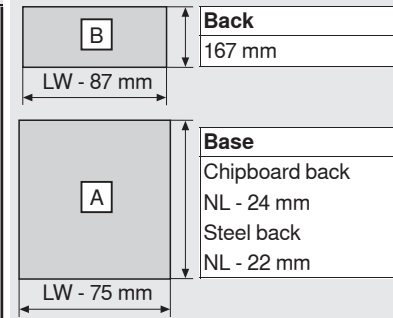

KB Cabinet width
LW Inner cabinet width
NL Nominal length

Cutting dimensions design element

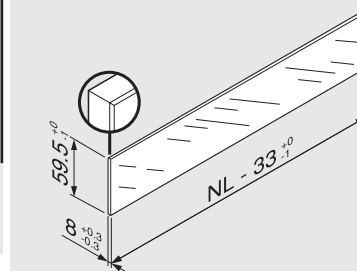

The given dimensions in combination with TANDEMBOX do not require "impact testing for vertically installed glass parts" as per the DIN EN 14749 norm Nov.2005. For norm compliance no safety glass is required.

The upper edge is a polished flat-ended edge with a 1 mm ±0.5 mm bevel.

Page instructions

Overview – TANDEMBOX antaro	263	Cabinet profile fixing positions	306
Overview – SERVO-DRIVE for TANDEMBOX	367	Assembly, removal and adjustment	308
Overview – TIP-ON for TANDEMBOX	407	Overview – assembly devices	605
Overview – ORGA-LINE for TANDEMBOX	561	More technical details	684
Accessories – design element	300		
Accessories – steel back	301		
Accessories	300		

Box systems

- ▶ TANDEMBOX antaro
- ▶▶ Standard cabinet



High fronted pull-out – gallery – D



- With simple gallery
- Design element possible
- Concealed, guided full extension
- TANDEM inside – unsurpassed running action – for the lifetime of the furniture
- Drawer sides made from steel silk white (SW), terra black (TS), RAL 9006 grey (white aluminium, R9006) and stainless steel (Inox)
- Tool-free front assembly
- 3-dimensional front adjustment
- Includes integrated **BLUMOTION** for silent and effortless closing action, can be combined with **SERVO-DRIVE**
- Or with an integrated **TIP-ON** function for handle-less fronts

Space requirement

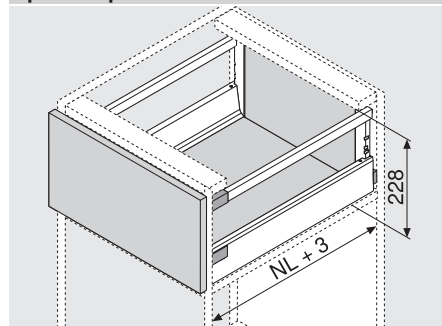

NL Nominal length

Order information

1	Cabinet profiles left/right			Cabinet profiles left/right	2	Drawer sides and cover caps left/right		8	Longside gallery rail left/right			
	BLUMOTION *			TIP-ON **		SW	TS R9006		Inox	SW	TS R9006	Inox
Nominal length NL	30 kg	50 kg	65 kg	20/30/50 kg	SW	TS	R9006	Inox	SW	TS	R9006	Inox
270 mm	558.2701B			559.2701T	358M2702SA				ZRG.207RSIC			ZRG.207RIIC
300 mm	558.3001B			559.3001T	358M3002SA				ZRG.237RSIC			ZRG.237RIIC
350 mm	558.3501B01			559.3501T	358M3502SA				ZRG.287RSIC			ZRG.287RIIC
400 mm	558.4001B01			559.4001T	358M4002SA				ZRG.337RSIC			ZRG.337RIIC
450 mm	558.4501B01	559.4501B	556.4501B	559.4501T	358M4502SA				ZRG.387RSIC			ZRG.387RIIC
500 mm	558.5001B	559.5001B	556.5001B	559.5001T	358M5002SA				ZRG.437RSIC			ZRG.437RIIC
550 mm	558.5501B	559.5501B	556.5501B	559.5501T	358M5502SA				ZRG.487RSIC			ZRG.487RIIC
600 mm		559.6001B	556.6001B	559.6001T	359M6002SA				ZRG.537RSIC			ZRG.537RIIC
650 mm		559.6501B	556.6501B	559.6501T	359M6502SA				ZRG.587RSIC			ZRG.587RIIC

* Suitable for **SERVO-DRIVE**

** Order specification, see TIP-ON for TANDEMBOX

3	Back fixing left/right		
	Material	Colour	Part no.
	Steel	SW, TS, R9006, NI	Z30D000SL

4	Front fixing bracket		
	Fixing method		Part no.
	INSERTA	2 x	ZSF.3902
	Screw-on	2 x	ZSF.3502
	Knock-in	2 x	ZSF.3602

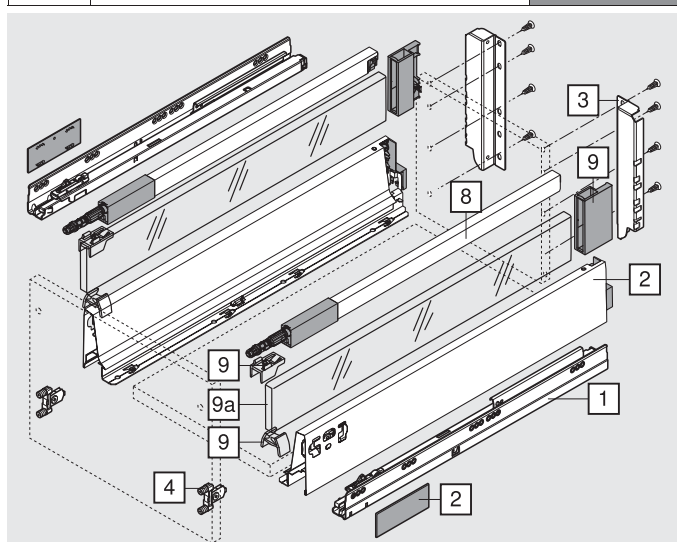

a	Accessories		
	Material	Colour	Part no.
9	Nylon	SW, S, WGR, R7037	Z36D0080

9a	Design element (side)		
	Material	Colour	Part no.
	Glass	Clear, frosted	2 x Z37Rxx7D
	Metal	SW, TS, R9006	2 x Z37Axx7D

Order specification, see accessories – design element

Colour			
SW	Silk white	S	Black
TS	Terra black	WGR	White grey
R9006	RAL 9006 grey (white aluminium)	R7037	RAL 7037 light grey
Inox	Stainless steel	NI	Nickel plated

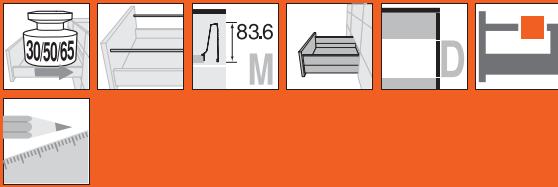

High fronted pull-out – gallery – D

Planning

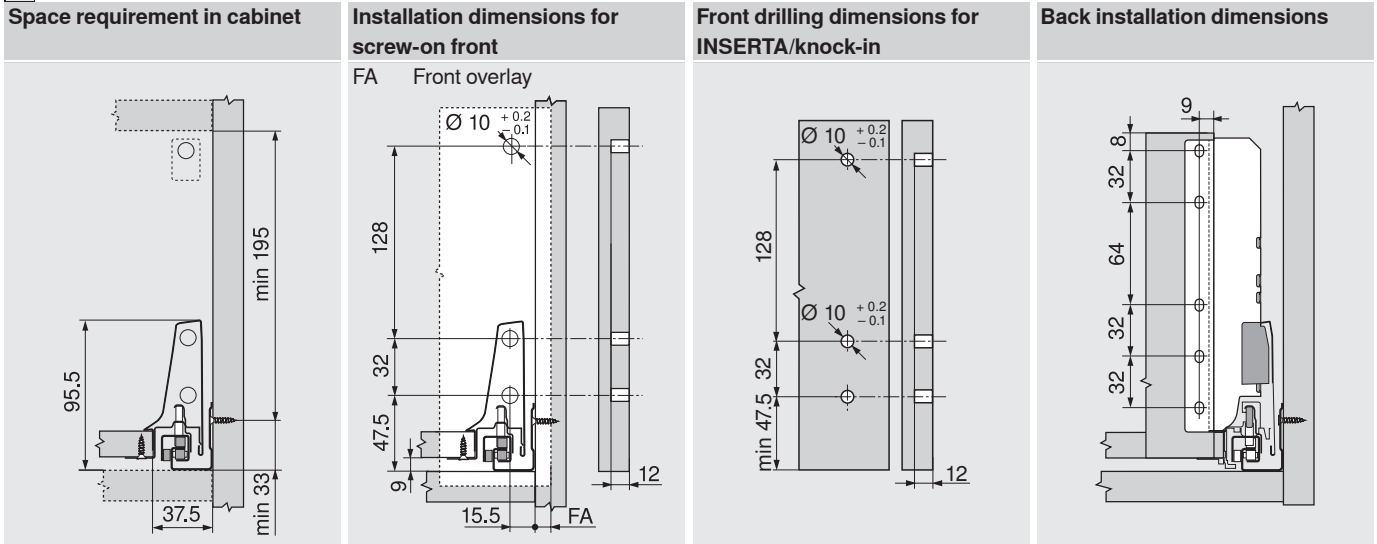

Cabinet profile screw positions

Nominal length NL (mm)

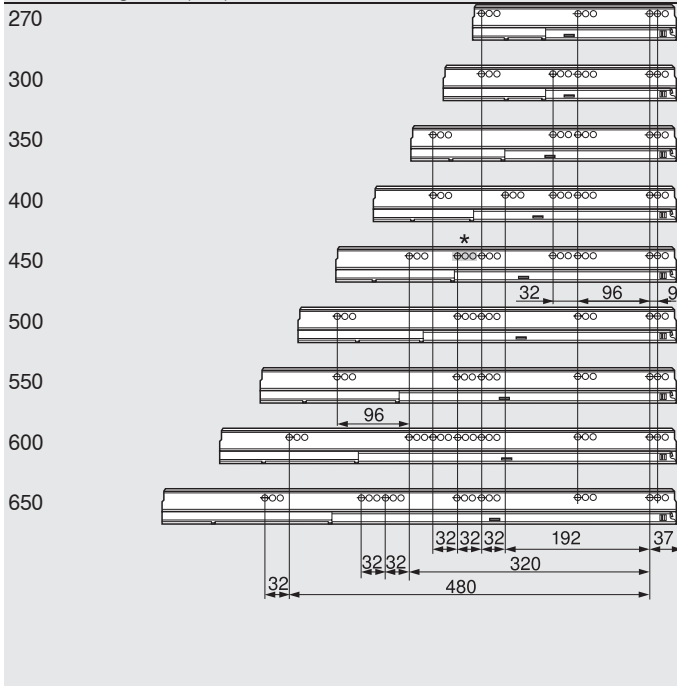

Min. internal cabinet depth = nominal length NL + 3 mm

* Only for 558.4501B01 (30 kg)

Cutting dimensions for 16 mm chipboard

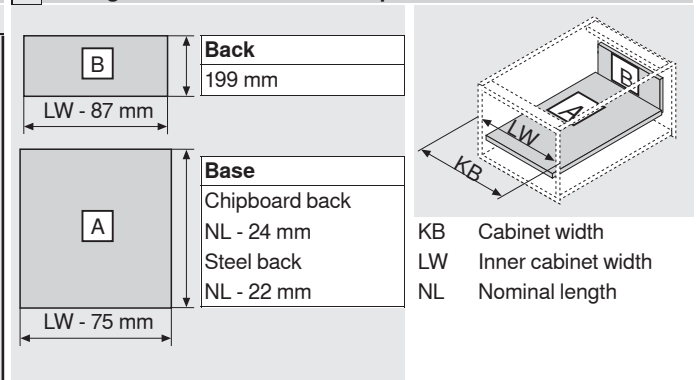

Cutting dimensions design element

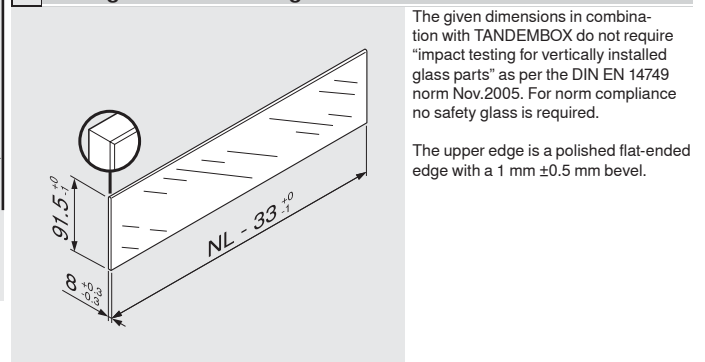

Page instructions

Overview – TANDEMBOX antaro	263	Cabinet profile fixing positions	306
Overview – SERVO-DRIVE for TANDEMBOX	367	Assembly, removal and adjustment	308
Overview – TIP-ON for TANDEMBOX	407	Overview – assembly devices	605
Overview – ORGA-LINE for TANDEMBOX	561	More technical details	684
Accessories – design element	300		
Accessories – steel back	301		
Accessories	300		

Box systems

- ▶ TANDEMBOX antaro
- ▶▶ Standard cabinet

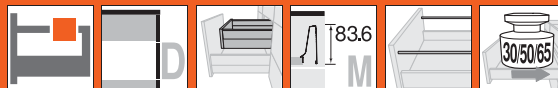

Inner pull-out – gallery – D



- With simple gallery
- Design element possible
- Concealed, guided full extension
- TANDEM inside – unsurpassed running action – for the lifetime of the furniture
- Drawer sides made from steel silk white (SW), terra black (TS), RAL 9006 grey (white aluminium, R9006) and stainless steel (Inox)
- Tool-free front assembly
- 3-dimensional front adjustment
- Includes integrated **BLUMOTION** for silent and effortless closing action, can be combined with **SERVO-DRIVE**
- Or with an integrated **TIP-ON** function for handle-less fronts

Space requirement

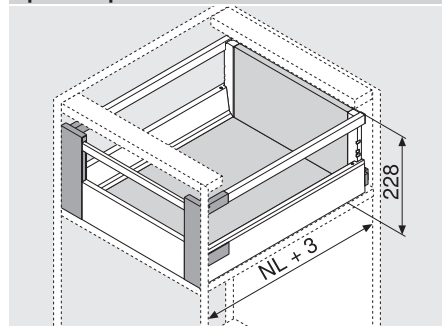

NL Nominal length

Order information

1	Cabinet profiles left/right			Cabinet profiles left/right	2	Drawer sides and cover caps left/right		8	Longside gallery rail left/right			
	BLUMOTION *					TIP-ON **	SW		TS R9006	Inox	SW	TS R9006
Nominal length NL	30 kg	50 kg	65 kg	20/30/50 kg	SW	TS	R9006	Inox	SW	TS	R9006	Inox
270 mm	558.2701B			559.2701T	358M2702SA	358M2702IA	ZRG.207RSIC	ZRG.207RIIC				
300 mm	558.3001B			559.3001T	358M3002SA	358M3002IA	ZRG.237RSIC	ZRG.237RIIC				
350 mm	558.3501B01			559.3501T	358M3502SA	358M3502IA	ZRG.287RSIC	ZRG.287RIIC				
400 mm	558.4001B01			559.4001T	358M4002SA	358M4002IA	ZRG.337RSIC	ZRG.337RIIC				
450 mm	558.4501B01	559.4501B	556.4501B	559.4501T	358M4502SA	358M4502IA	ZRG.387RSIC	ZRG.387RIIC				
500 mm	558.5001B	559.5001B	556.5001B	559.5001T	358M5002SA	358M5002IA	ZRG.437RSIC	ZRG.437RIIC				
550 mm	558.5501B	559.5501B	556.5501B	559.5501T	358M5502SA	358M5502IA	ZRG.487RSIC	ZRG.487RIIC				
600 mm		559.6001B	556.6001B	559.6001T	359M6002SA	359M6002IA	ZRG.537RSIC	ZRG.537RIIC				
650 mm		559.6501B	556.6501B	559.6501T	359M6502SA	359M6502IA	ZRG.587RSIC	ZRG.587RIIC				

* Suitable for SERVO-DRIVE

** Order specification, see TIP-ON for TANDEMBOX

3	Back fixing left/right		
	Material	Colour	Part no.
	Steel	SW, TS, R9006, NI	Z30D000SL

4	Front fixing left/right		
	Material	Colour	Part no.
	Nylon	SW, S, WGR, R7037	ZIF.74D0
	Incl. locking piece Z31A0008		
	Incl. 2 x gallery head ZRG.000R5F		

5	Front piece without groove		
	Colour	Length	Part no.
	SW, TS, R9006, NI	For cutting to size, 1036 mm	Z31L1036A
	Cutting	Internal cabinet width LW - 132 mm	

7	Cross gallery		
	Colour	Length	Part no.
	SW, TS, R9006, NI	For cutting to size, 1046 mm	ZRG.1046Z
	Cutting	Internal cabinet width LW - 122 mm	

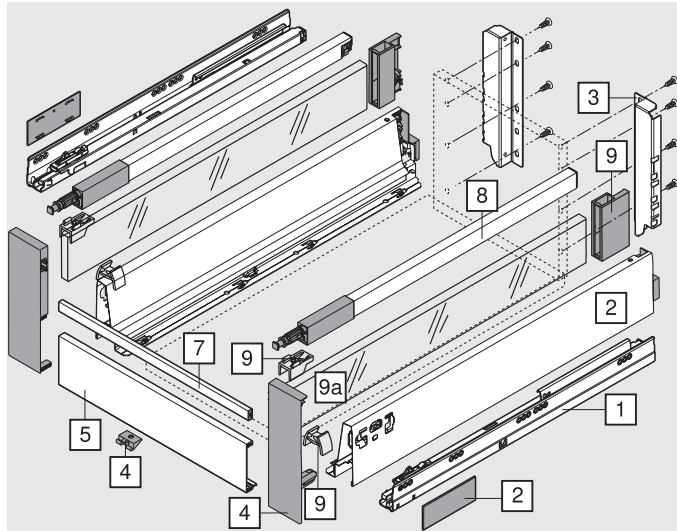

a Accessories			
9	Locking piece set		
	Material	Colour	Part no.
	Nylon	SW, S, WGR, R7037	Z36D0080

9a	Design element (side)		
	Material	Colour	Part no.
	Glass	Clear, frosted	2 x Z37Rxx7D
	Metal	SW, TS, R9006	2 x Z37Axx7D

Order specification, see accessories – design element

Colour			
SW	Silk white	S	Black
TS	Terra black	WGR	White grey
R9006	RAL 9006 grey (white aluminium)	R7037	RAL 7037 light grey
Inox	Stainless steel	NI	Nickel plated



Inner pull-out – gallery – D

Planning

Space requirement in cabinet

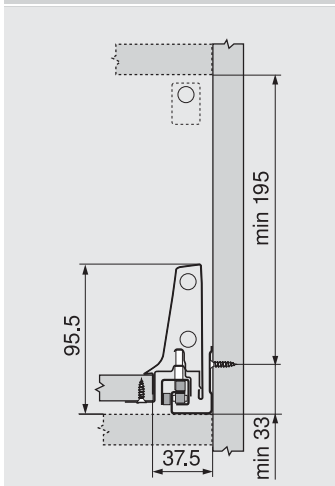

Back installation dimensions

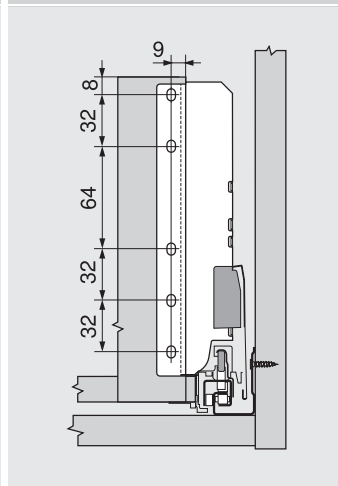

Cabinet profile screw positions

Nominal length NL (mm)

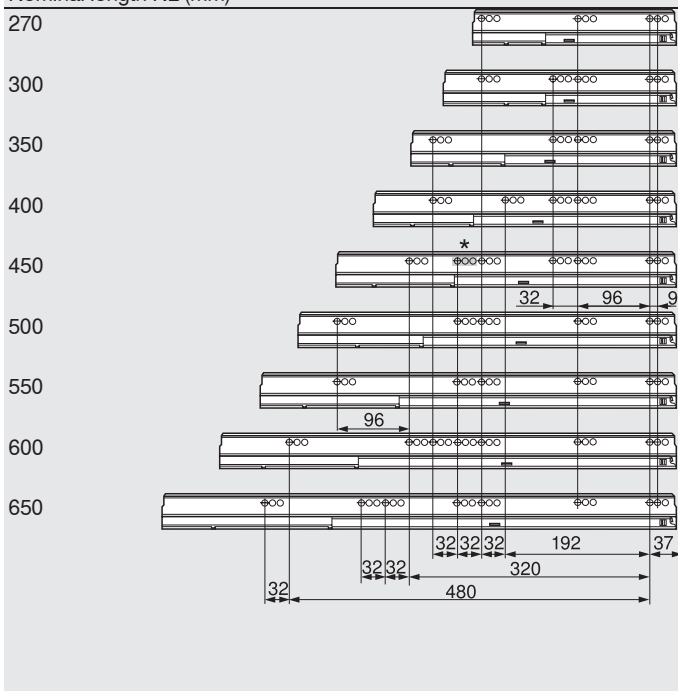

Min. internal cabinet depth = nominal length NL + 3 mm

* Only for 558.4501B01 (30 kg)

Cutting dimensions for 16 mm chipboard

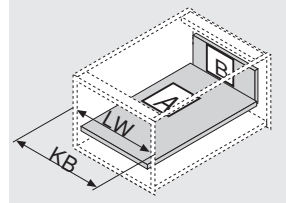
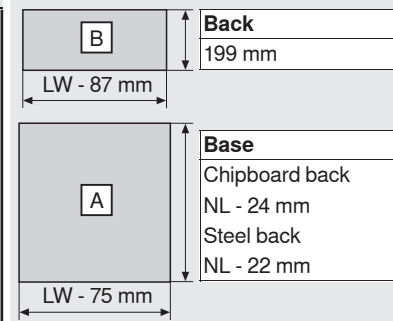

KB Cabinet width
LW Inner cabinet width
NL Nominal length

Cutting dimensions design element

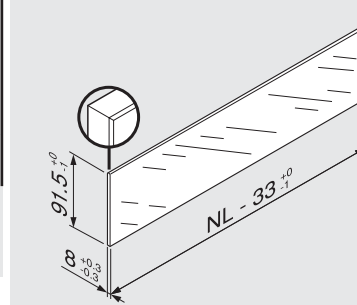

The given dimensions in combination with TANDEMBOX do not require "impact testing for vertically installed glass parts" as per the DIN EN 14749 norm Nov.2005. For norm compliance no safety glass is required.

The upper edge is a polished flat-ended edge with a 1 mm ±0.5 mm bevel.

Page instructions

Overview – TANDEMBOX antaro	263	Cabinet profile fixing positions	306
Overview – SERVO-DRIVE for TANDEMBOX	367	Assembly, removal and adjustment	308
Overview – TIP-ON for TANDEMBOX	407	Overview – assembly devices	605
Overview – ORGA-LINE for TANDEMBOX	561	More technical details	684
Accessories – design element	300		
Accessories – steel back	301		
Accessories	300		

Box systems

- ▶ TANDEMBOX antaro
- ▶▶ Standard cabinet



High fronted pull-out – gallery – D – K drawer side



- With simple gallery
- Concealed, guided full extension
- TANDEM inside – unsurpassed running action – for the lifetime of the furniture
- Drawer sides made from steel silk white (SW), terra black (TS), RAL 9006 grey (white aluminium, R9006)
- Tool-free front assembly
- 3-dimensional front adjustment
- Includes integrated **BLUMOTION** for silent and effortless closing action, can be combined with **SERVO-DRIVE**
- Or with an integrated **TIP-ON** function for handle-less fronts

Space requirement

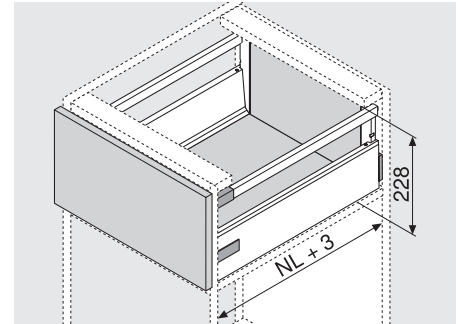

NL Nominal length

Order information

1	Cabinet profiles left/right			Cabinet profiles left/right	2	Drawer sides, cover caps and positioning dowels left/right			8	Longside gallery rail left/right		
	BLUMOTION *					TIP-ON **	Nominal length NL	SW		TS	R9006	Nominal length NL
Nominal length NL	30 kg	50 kg	65 kg	20/30/50 kg	Nominal length NL	SW	TS	R9006	Nominal length NL	SW	TS	R9006
270 mm	558.2701B			559.2701T	270 mm	358K2702SA			270 mm	ZRG.207RSIC		
300 mm	558.3001B			559.3001T	300 mm	358K3002SA			300 mm	ZRG.237RSIC		
350 mm	558.3501B01			559.3501T	350 mm	358K3502SA			350 mm	ZRG.287RSIC		
400 mm	558.4001B01			559.4001T	400 mm	358K4002SA			400 mm	ZRG.337RSIC		
450 mm	558.4501B01	559.4501B	556.4501B	559.4501T	450 mm	358K4502SA			450 mm	ZRG.387RSIC		
500 mm	558.5001B	559.5001B	556.5001B	559.5001T	500 mm	358K5002SA			500 mm	ZRG.437RSIC		
550 mm	558.5501B	559.5501B	556.5501B	559.5501T	550 mm	358K5502SA			550 mm	ZRG.487RSIC		
600 mm		559.6001B	556.6001B	559.6001T	600 mm	359K6002SA			600 mm	ZRG.537RSIC		
650 mm		559.6501B	556.6501B	559.6501T	650 mm	359K6502SA			650 mm	ZRG.587RSIC		

* Suitable for **SERVO-DRIVE**

** Order specification, see TIP-ON for TANDEMBOX

3	Back fixing left/right		
	Material	Colour	Part no.
	Steel	SW, TS, R9006	Z30D000SL

4	Front fixing bracket		
	Fixing method		Part no.
	INSERTA	2 x	ZSF.3902
	Screw-on	2 x	ZSF.3502
	Knock-in	2 x	ZSF.3602

Colour			
SW	Silk white	S	Black
TS	Terra black	WGR	White grey
R9006	RAL 9006 grey (white aluminium)	R7037	RAL 7037 light grey
Inox	Stainless steel	NI	Nickel plated

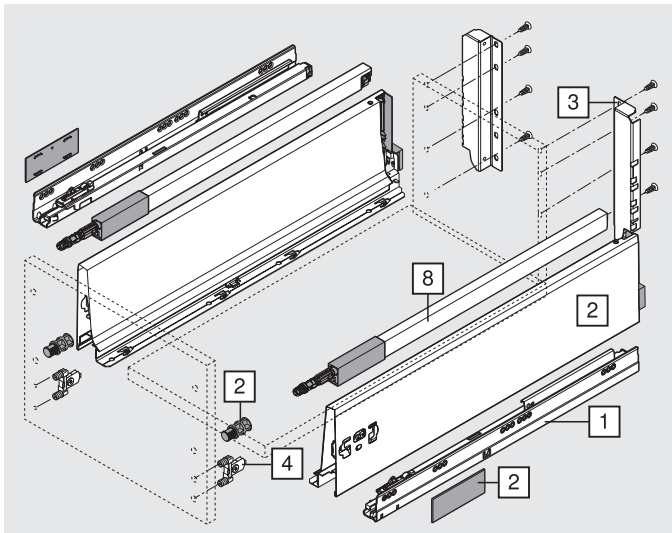

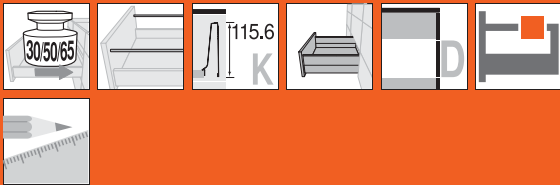

High fronted pull-out – gallery – D – K drawer side

Planning

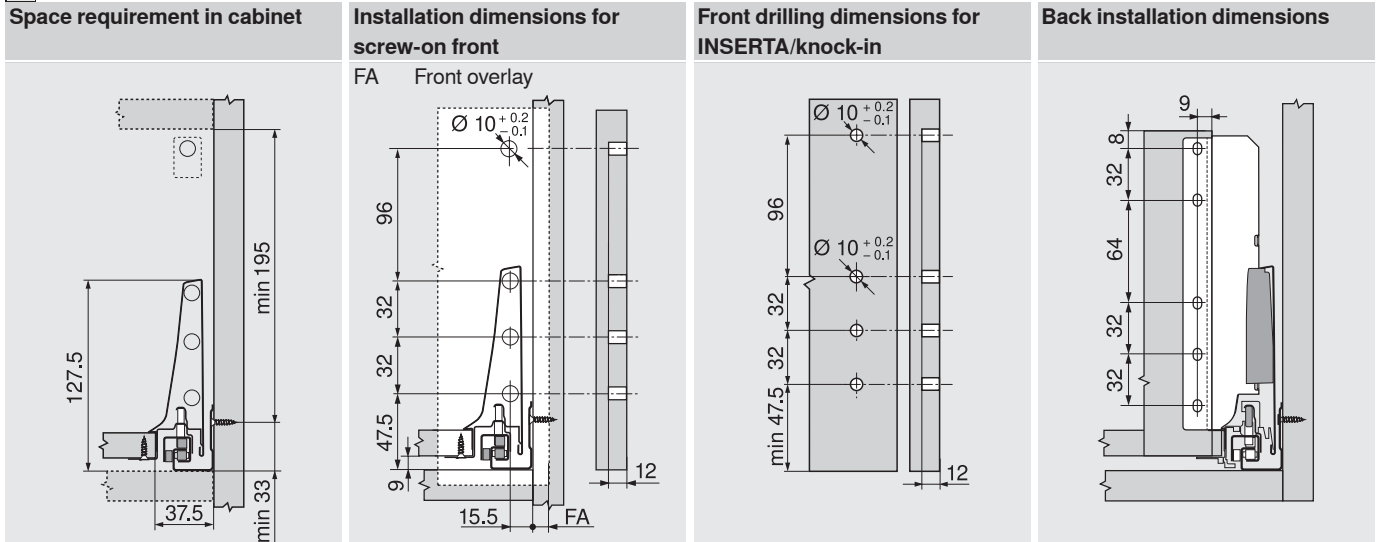

Cabinet profile screw positions

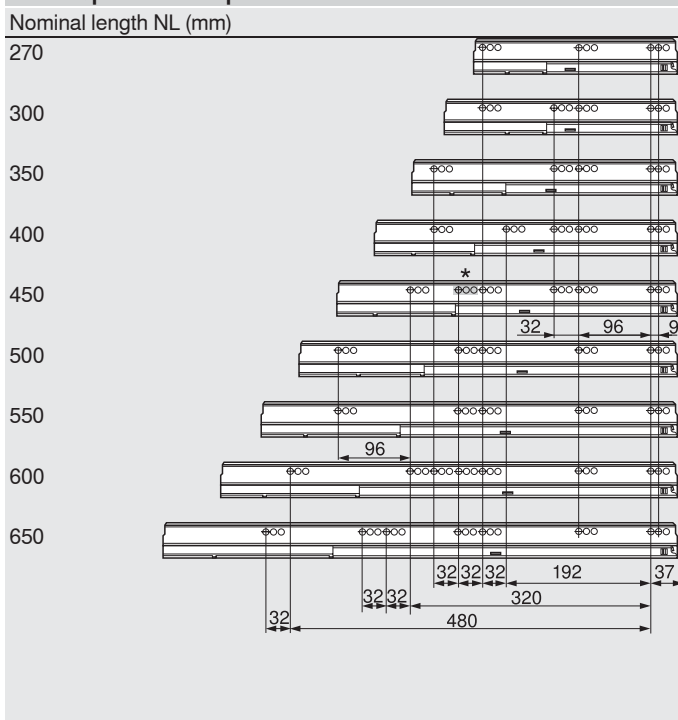

Cutting dimensions for 16 mm chipboard

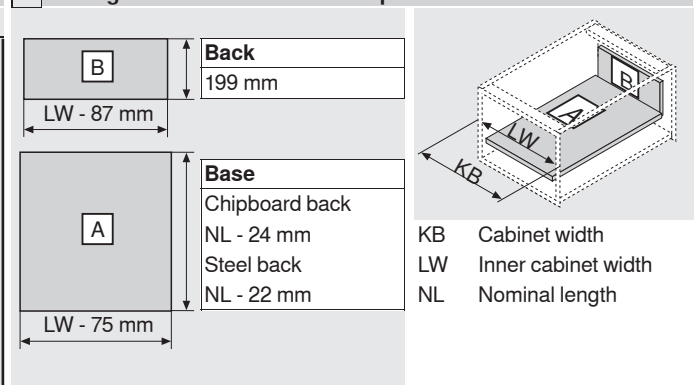

Min. internal cabinet depth = nominal length NL + 3 mm

* Only for 558.4501B01 (30 kg)

Page instructions

Overview – TANDEMBOX antaro	263	Assembly, removal and adjustment	308
Overview – SERVO-DRIVE for TANDEMBOX		Overview – assembly devices	605
	367	More technical details	684
Overview – TIP-ON for TANDEMBOX			
	407		
Overview – ORGA-LINE for TANDEMBOX			
	561		
Accessories – steel back	301		
Accessories	300		
Cabinet profile fixing positions	306		

Box systems

- ▶ TANDEMBOX antaro
- ▶▶ Standard cabinet

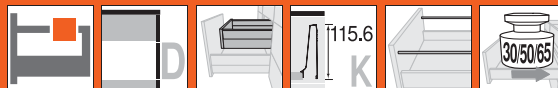

Inner pull-out – gallery – D – K drawer side



- With simple gallery
- Concealed, guided full extension
- TANDEM inside – unsurpassed running action – for the lifetime of the furniture
- Drawer sides made from steel silk white (SW), terra black (TS), RAL 9006 grey (white aluminium, R9006)
- Tool-free front assembly
- 3-dimensional front adjustment
- Includes integrated **BLUMOTION** for silent and effortless closing action, can be combined with **SERVO-DRIVE**
- Or with an integrated **TIP-ON** function for handle-less fronts

Space requirement

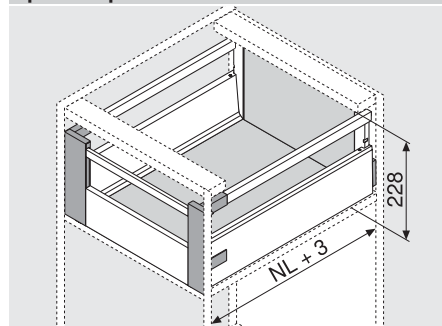

NL Nominal length

Order information

1	Cabinet profiles left/right			Cabinet profiles left/right	2	Drawer sides, cover caps and positioning dowels left/right			8	Longside gallery rail left/right		
	BLUMOTION *			TIP-ON **		Nominal length NL	SW	TS		R9006	Nominal length NL	SW
Nominal length NL	30 kg	50 kg	65 kg	20/30/50 kg	Nominal length NL	SW	TS	R9006	Nominal length NL	SW	TS	R9006
270 mm	558.2701B			559.2701T	270 mm	358K2702SA			270 mm	ZRG.207RSIC		
300 mm	558.3001B			559.3001T	300 mm	358K3002SA			300 mm	ZRG.237RSIC		
350 mm	558.3501B01			559.3501T	350 mm	358K3502SA			350 mm	ZRG.287RSIC		
400 mm	558.4001B01			559.4001T	400 mm	358K4002SA			400 mm	ZRG.337RSIC		
450 mm	558.4501B01	559.4501B	556.4501B	559.4501T	450 mm	358K4502SA			450 mm	ZRG.387RSIC		
500 mm	558.5001B	559.5001B	556.5001B	559.5001T	500 mm	358K5002SA			500 mm	ZRG.437RSIC		
550 mm	558.5501B	559.5501B	556.5501B	559.5501T	550 mm	358K5502SA			550 mm	ZRG.487RSIC		
600 mm		559.6001B	556.6001B	559.6001T	600 mm	359K6002SA			600 mm	ZRG.537RSIC		
650 mm		559.6501B	556.6501B	559.6501T	650 mm	359K6502SA			650 mm	ZRG.587RSIC		

* Suitable for **SERVO-DRIVE**

** Order specification, see TIP-ON for TANDEMBOX

3	Back fixing left/right		
	Material	Colour	Part no.
	Steel	SW, TS, R9006	Z30D000SL

4	Front fixing left/right		
	Material	Colour	Part no.
	Nylon	SW, S, WGR	ZIF.74D0
	Incl. locking piece Z31A0008		
	Incl. 2 x gallery head ZRG.000R5F		

5	Front piece without groove		
	Colour	Length	Part no.
	SW, TS, R9006	For cutting to size, 1036 mm	Z31L1036A
	Cutting	Internal cabinet width LW - 132 mm	

7	Cross gallery		
	Colour	Length	Part no.
	SW, TS, R9006	For cutting to size, 1046 mm	ZRG.1046Z
	Cutting	Internal cabinet width LW - 122 mm	

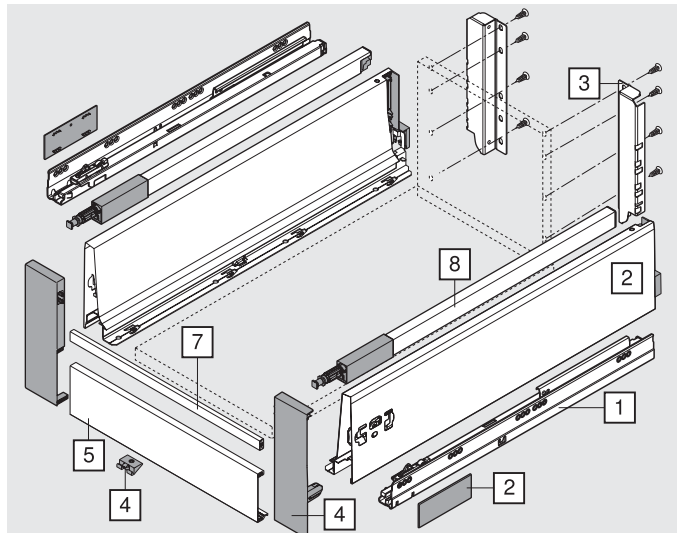

Colour			
SW	Silk white	S	Black
TS	Terra black	WGR	White grey
R9006	RAL 9006 grey (white aluminium)	R7037	RAL 7037 light grey
Inox	Stainless steel	NI	Nickel plated

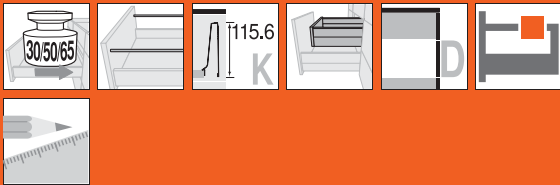

Inner pull-out – gallery – D – K drawer side

Planning

Space requirement in cabinet

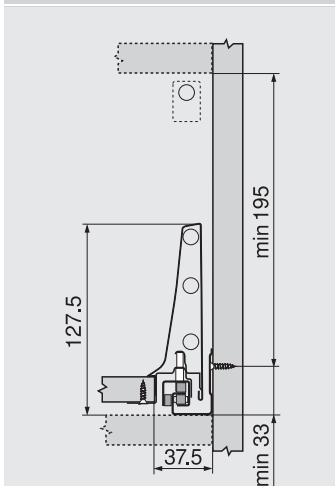

Back installation dimensions

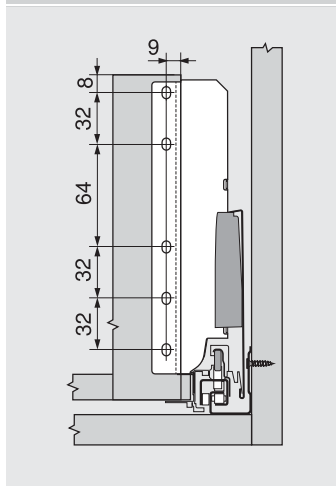

Cabinet profile screw positions

Nominal length NL (mm)

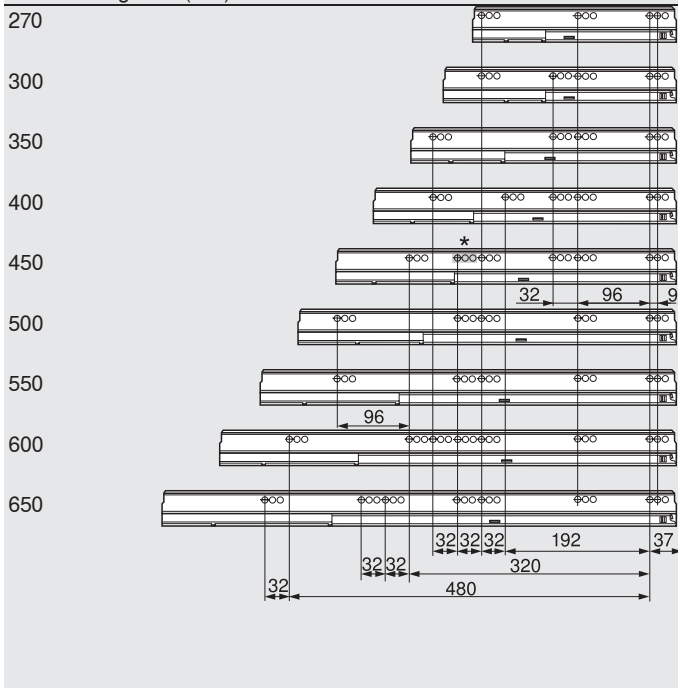

Min. internal cabinet depth = nominal length NL + 3 mm

* Only for 558.4501B01 (30 kg)

Cutting dimensions for 16 mm chipboard

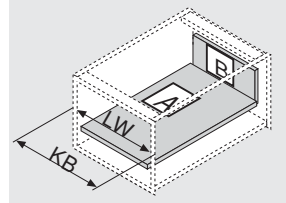
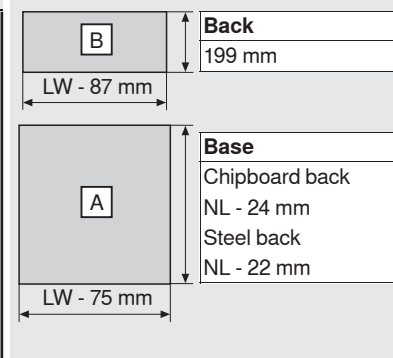

KB Cabinet width
LW Inner cabinet width
NL Nominal length

Page instructions

Overview – TANDEMBOX antaro	263	Assembly, removal and adjustment	308
Overview – SERVO-DRIVE for TANDEMBOX		Overview – assembly devices	605
	367	More technical details	684
Overview – TIP-ON for TANDEMBOX			
	407		
Overview – ORGA-LINE for TANDEMBOX			
	561		
Accessories – steel back	301		
Accessories	300		
Cabinet profile fixing positions	306		

Box systems

- ▶ TANDEMBOX antaro
- ▶▶ Standard cabinet



High fronted pull-out – gallery – C – alu frames



- With simple gallery
- Design element possible
- Concealed, guided full extension
- TANDEM inside – unsurpassed running action – for the lifetime of the furniture
- Drawer sides made from steel silk white (SW), terra black (TS), RAL 9006 grey (white aluminium, R9006) and stainless steel (Inox)
- Tool-free front assembly
- 3-dimensional front adjustment
- Includes integrated **BLUMOTION** for silent and effortless closing action, can be combined with **SERVO-DRIVE**
- Or with an integrated **TIP-ON** function for handle-less fronts

Space requirement

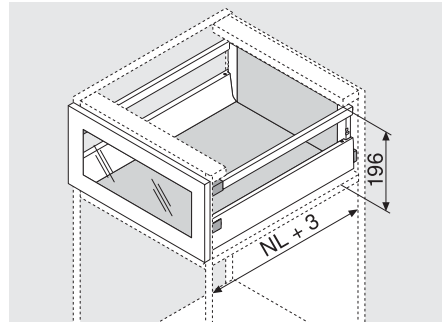

NL Nominal length

Order information

1	Cabinet profiles left/right			Cabinet profiles left/right	2	Drawer sides and cover caps left/right		8	Longside gallery rail left/right			
	BLUMOTION *					TIP-ON **	SW		TS R9006	Inox	SW	TS R9006
Nominal length NL	30 kg	50 kg	65 kg	20/30/50 kg	SW	TS	R9006	Inox	SW	TS	R9006	Inox
270 mm	558.2701B			559.2701T	358M2702SA	358M2702IA			ZRG.207RSIC	ZRG.207RIIC		
300 mm	558.3001B			559.3001T	358M3002SA	358M3002IA			ZRG.237RSIC	ZRG.237RIIC		
350 mm	558.3501B01			559.3501T	358M3502SA	358M3502IA			ZRG.287RSIC	ZRG.287RIIC		
400 mm	558.4001B01			559.4001T	358M4002SA	358M4002IA			ZRG.337RSIC	ZRG.337RIIC		
450 mm	558.4501B01	559.4501B	556.4501B	559.4501T	358M4502SA	358M4502IA			ZRG.387RSIC	ZRG.387RIIC		
500 mm	558.5001B	559.5001B	556.5001B	559.5001T	358M5002SA	358M5002IA			ZRG.437RSIC	ZRG.437RIIC		
550 mm	558.5501B	559.5501B	556.5501B	559.5501T	358M5502SA	358M5502IA			ZRG.487RSIC	ZRG.487RIIC		
600 mm		559.6001B	556.6001B	559.6001T	359M6002SA	359M6002IA			ZRG.537RSIC	ZRG.537RIIC		
650 mm		559.6501B	556.6501B	559.6501T	359M6502SA	359M6502IA			ZRG.587RSIC	ZRG.587RIIC		

* Suitable for SERVO-DRIVE

** Order specification, see TIP-ON for TANDEMBOX

3	Back fixing left/right		
Material	Colour	Part no.	
Steel	SW, TS, R9006, NI	Z30C000S	

4	Front fixing bracket		
Fixing method	Part no.		
Screw-on	2 x	ZSF.3502	

4a	Adapter for aluminium frames		
Material	Colour	Part no.	
Nylon	Natural	2 x	ZRF.2200.01

Use countersunk screw Ø 7 x 3.5 mm

8a	Gallery head		
Material	Colour	Part no.	
Nylon	Natural	2 x	ZRG.000R5F

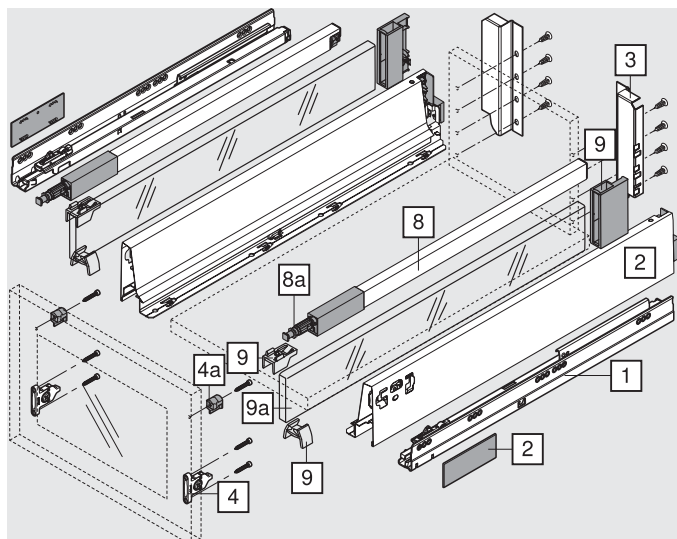

a	Accessories		
9	Locking piece set		
Material	Colour	Part no.	
Nylon	SW, S, WGR, R7037	Z36C0080	

9a	Design element (side)		
Material	Colour	Part no.	
Glass	Clear, frosted	2 x	Z37Rxx7C
Metal	SW, TS, R9006	2 x	Z37Axx7C

Order specification, see accessories – design element

Colour			
SW	Silk white	S	Black
TS	Terra black	WGR	White grey
R9006	RAL 9006 grey (white aluminium)	R7037	RAL 7037 light grey
Inox	Stainless steel	NI	Nickel plated



High fronted pull-out – gallery – C – alu frames

Planning

Space requirement in cabinet

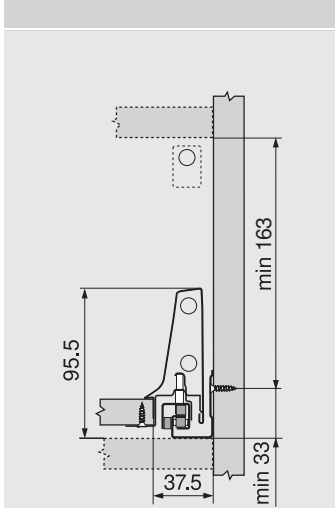

Installation dimensions for screw-on front

FA Front overlay

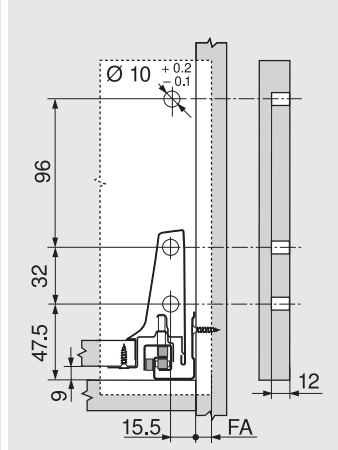

Back installation dimensions

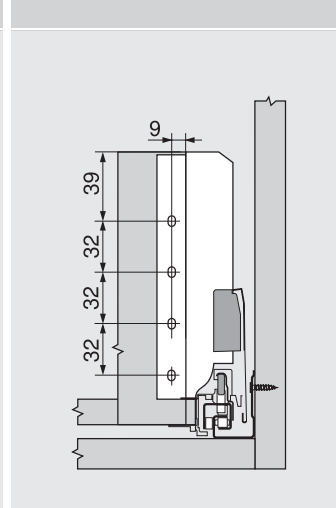

Cabinet profile screw positions

Nominal length NL (mm)

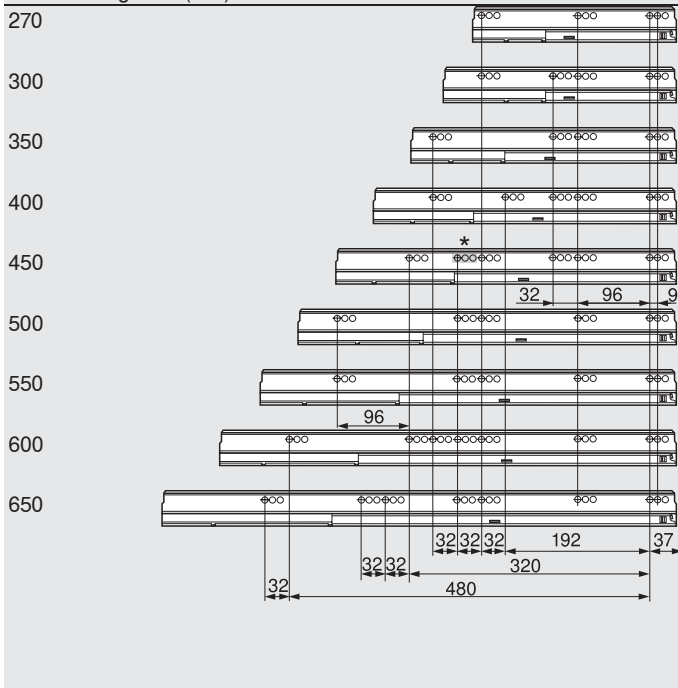

Min. internal cabinet depth = nominal length NL + 3 mm

* Only for 558.4501B01 (30 kg)

Cutting dimensions for 16 mm chipboard

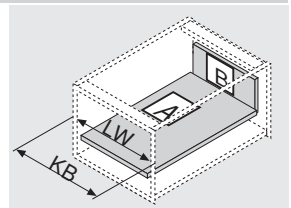
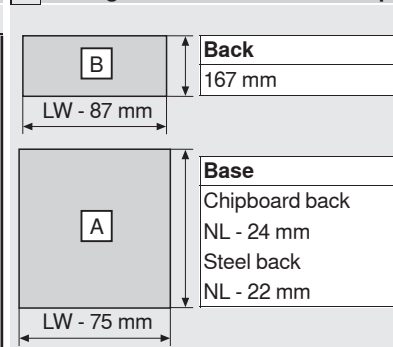

KB Cabinet width
LW Inner cabinet width
NL Nominal length

Cutting dimensions design element

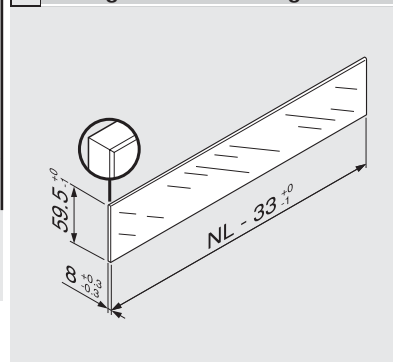

The given dimensions in combination with TANDEMBOX do not require "impact testing for vertically installed glass parts" as per the DIN EN 14749 norm Nov.2005. For norm compliance no safety glass is required.

The upper edge is a polished flat-ended edge with a 1 mm ±0.5 mm bevel.

Page instructions

Overview – TANDEMBOX antaro	263	Cabinet profile fixing positions	306
Overview – SERVO-DRIVE for TANDEMBOX	367	Assembly, removal and adjustment	308
Overview – TIP-ON for TANDEMBOX	407	Overview – assembly devices	605
Overview – ORGA-LINE for TANDEMBOX	561	More technical details	684
Accessories – design element	300		
Accessories – steel back	301		
Accessories	300		

Box systems

- ▶ TANDEMBOX antaro
- ▶▶ Standard cabinet



High fronted pull-out – gallery – D – alu frames



- With simple gallery
- Design element possible
- Concealed, guided full extension
- TANDEM inside – unsurpassed running action – for the lifetime of the furniture
- Drawer sides made from steel silk white (SW), terra black (TS), RAL 9006 grey (white aluminium, R9006) and stainless steel (Inox)
- Tool-free front assembly
- 3-dimensional front adjustment
- Includes integrated **BLUMOTION** for silent and effortless closing action, can be combined with **SERVO-DRIVE**
- Or with an integrated **TIP-ON** function for handle-less fronts

Space requirement

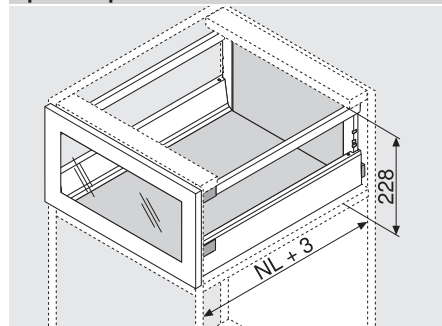

NL Nominal length

Order information

1	Cabinet profiles left/right			Cabinet profiles left/right	2	Drawer sides and cover caps left/right		8	Longside gallery rail left/right			
	BLUMOTION *					TIP-ON **	SW		TS R9006	Inox	SW	TS R9006
Nominal length NL	30 kg	50 kg	65 kg	20/30/50 kg	SW	TS	R9006	Inox	SW	TS	R9006	Inox
270 mm	558.2701B			559.2701T	358M2702SA	358M2702IA			ZRG.207RSIC	ZRG.207RIIC		
300 mm	558.3001B			559.3001T	358M3002SA	358M3002IA			ZRG.237RSIC	ZRG.237RIIC		
350 mm	558.3501B01			559.3501T	358M3502SA	358M3502IA			ZRG.287RSIC	ZRG.287RIIC		
400 mm	558.4001B01			559.4001T	358M4002SA	358M4002IA			ZRG.337RSIC	ZRG.337RIIC		
450 mm	558.4501B01	559.4501B	556.4501B	559.4501T	358M4502SA	358M4502IA			ZRG.387RSIC	ZRG.387RIIC		
500 mm	558.5001B	559.5001B	556.5001B	559.5001T	358M5002SA	358M5002IA			ZRG.437RSIC	ZRG.437RIIC		
550 mm	558.5501B	559.5501B	556.5501B	559.5501T	358M5502SA	358M5502IA			ZRG.487RSIC	ZRG.487RIIC		
600 mm		559.6001B	556.6001B	559.6001T	359M6002SA	359M6002IA			ZRG.537RSIC	ZRG.537RIIC		
650 mm		559.6501B	556.6501B	559.6501T	359M6502SA	359M6502IA			ZRG.587RSIC	ZRG.587RIIC		

* Suitable for SERVO-DRIVE

** Order specification, see TIP-ON for TANDEMBOX

3	Back fixing left/right		
	Material	Colour	Part no.
	Steel	SW, TS, R9006, NI	Z30D000SL

4	Front fixing bracket		
	Fixing method		Part no.
	Screw-on	2 x	ZSF.3502

4a	Adapter for aluminium frames		
	Material	Colour	Part no.
	Nylon	Natural	2 x ZRF.2200.01

Use countersunk screw Ø 7 x 3.5 mm

8a	Gallery head		
	Material	Colour	Part no.
	Nylon	Natural	2 x ZRG.000R5F

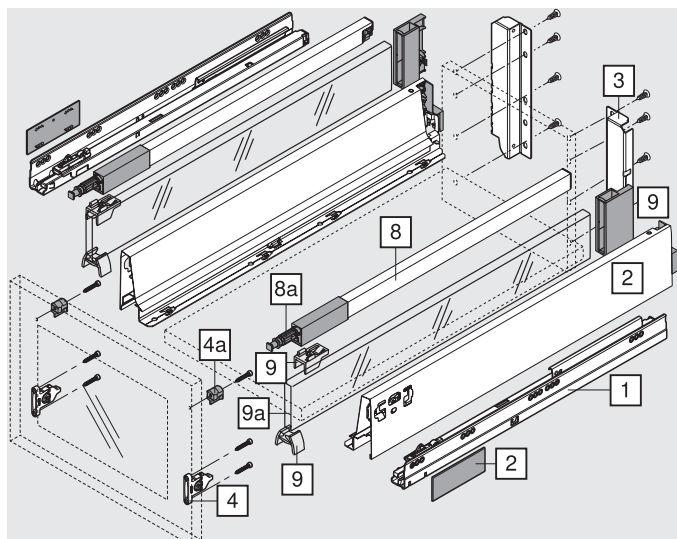

a Accessories

9	Locking piece set		
	Material	Colour	Part no.
	Nylon	SW, S, WGR, R7037	Z36D0080

9a	Design element (side)		
	Material	Colour	Part no.
	Glass	Clear, frosted	2 x Z37Rxx7D
	Metal	SW, TS, R9006	2 x Z37Axx7D

Order specification, see accessories – design element

Colour			
SW	Silk white	S	Black
TS	Terra black	WGR	White grey
R9006	RAL 9006 grey (white aluminium)	R7037	RAL 7037 light grey
Inox	Stainless steel	NI	Nickel plated

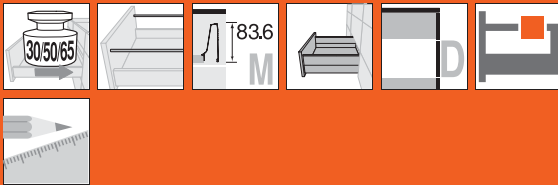

High fronted pull-out – gallery – D – alu frames

Planning

Space requirement in cabinet

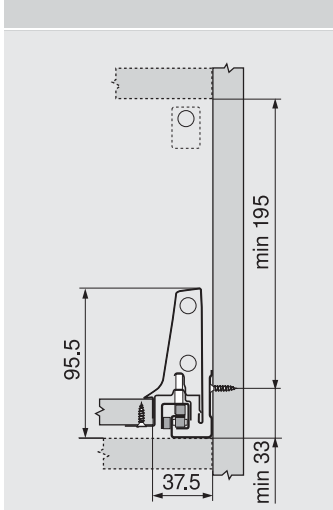

Installation dimensions for screw-on front

FA Front overlay

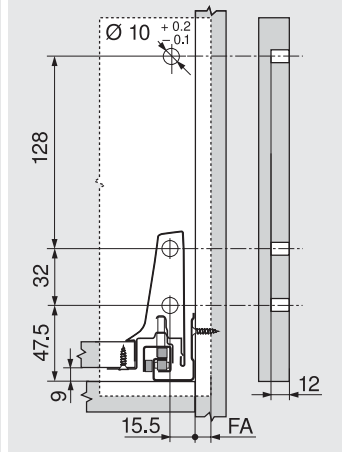

Back installation dimensions

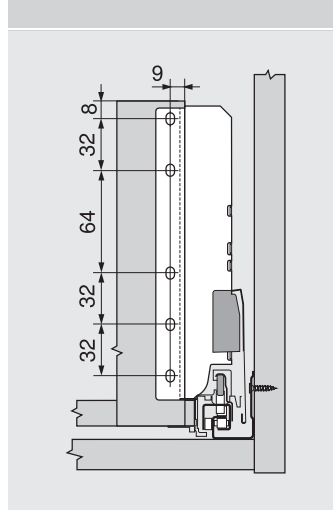

Cabinet profile screw positions

Nominal length NL (mm)

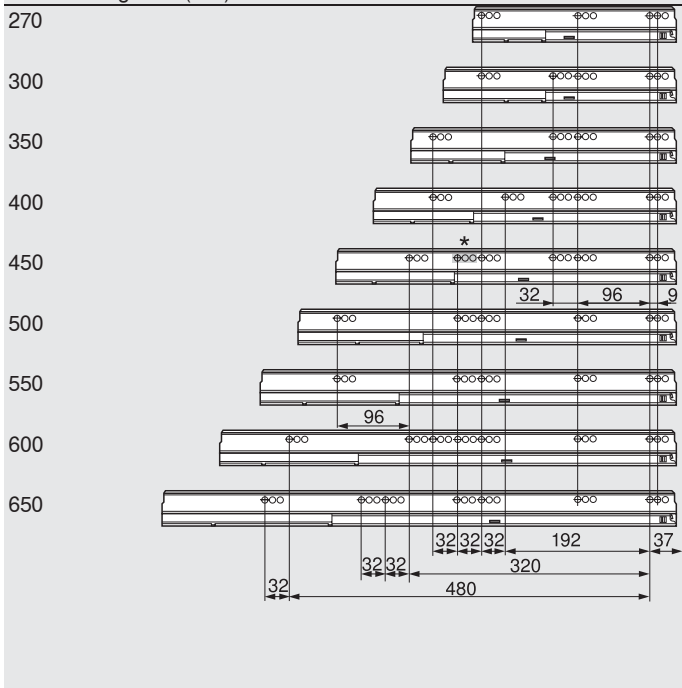

Min. internal cabinet depth = nominal length NL + 3 mm

* Only for 558.4501B01 (30 kg)

Cutting dimensions for 16 mm chipboard

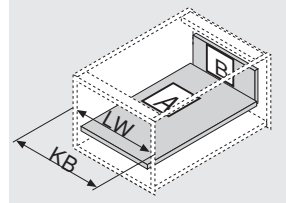
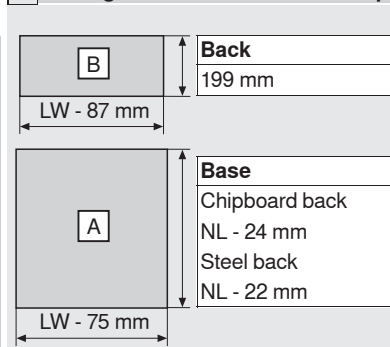

KB Cabinet width
LW Inner cabinet width
NL Nominal length

Cutting dimensions design element

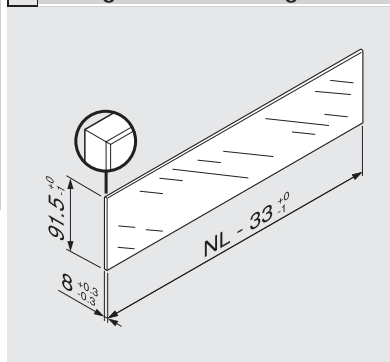

The given dimensions in combination with TANDEMBOX do not require "impact testing for vertically installed glass parts" as per the DIN EN 14749 norm Nov.2005. For norm compliance no safety glass is required.

The upper edge is a polished flat-ended edge with a 1 mm ±0.5 mm bevel.

Page instructions

Overview – TANDEMBOX antaro	263	Cabinet profile fixing positions	306
Overview – SERVO-DRIVE for TANDEMBOX	367	Assembly, removal and adjustment	308
Overview – TIP-ON for TANDEMBOX	407	Overview – assembly devices	605
Overview – ORGA-LINE for TANDEMBOX	561	More technical details	684
Accessories – design element	300		
Accessories – steel back	301		
Accessories	300		

Box systems

- ▶ TANDEMBOX antaro
- ▶▶ Corner cabinet

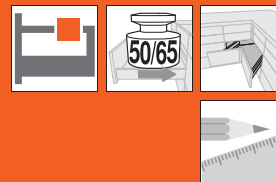











SPACE CORNER with SYNCROMOTION

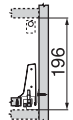

- Inspiring opening and closing function with SYNCROMOTION
- Use of standard fronts
- With simple gallery
- Design element possible
- Concealed, guided full extension
- TANDEM inside – unsurpassed running action – for the lifetime of the furniture
- Drawer sides made from steel silk white (SW), terra black (TS), RAL 9006 grey (white aluminium, R9006) and stainless steel (Inox)
- 3-dimensional front adjustment
- Includes integrated **BLUMOTION** for silent and effortless closing action

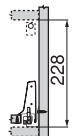
Order information

Drawer		Colour		
	Drawer – M		SW Silk white TS Terra black R9006 RAL 9006 grey (white aluminium) Inox Stainless steel	 
High fronted pull-out		Colour		
	High fronted pull-out – gallery – C		SW Silk white TS Terra black R9006 RAL 9006 grey (white aluminium) Inox Stainless steel	 
	Design element possible			
	High fronted pull-out – gallery – D		SW Silk white TS Terra black R9006 RAL 9006 grey (white aluminium) Inox Stainless steel	 
	Design element possible			

Please use our **DYNALOG** ordering software for all your ordering needs!

Planning

Please use our **DYNALOG (DYNAPLAN)** planning software for all your planning needs.

Page instructions

Overview – TANDEMBOX antaro	263	More technical details	684
Overview – ORGA-LINE for TANDEMBOX	561		
Accessories – design element	300		
Cutting dimensions design element C high	276		
Cutting dimensions design element D high	281		
Accessories	300		
Cabinet profile fixing positions	306		
Assembly, removal and adjustment	363		
Overview – assembly devices	605		

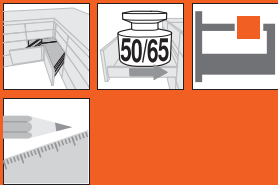







SPACE CORNER with rigid fronts

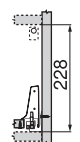

- Using special fronts
- With simple gallery
- Design element possible
- Concealed, guided full extension
- TANDEM inside – unsurpassed running action
– for the lifetime of the furniture
- Drawer sides made from steel silk white (SW), terra black (TS), RAL 9006 grey (white aluminium, R9006) and stainless steel (Inox)
- 3-dimensional front adjustment
- Includes integrated **BLUMOTION** for silent and effortless closing action, can be combined with **SERVO-DRIVE**
- Or with an integrated **TIP-ON** function for handle-less fronts

Order information

Drawer		Colour		
	Drawer – M		SW Silk white TS Terra black R9006 RAL 9006 grey (white aluminium) Inox Stainless steel	 
High fronted pull-out		Colour		
	High fronted pull-out – gallery – D Design element possible		SW Silk white TS Terra black R9006 RAL 9006 grey (white aluminium) Inox Stainless steel	 

Please use our **DYNALOG (DYNAPLAN)** ordering software for all your ordering needs!

Planning

Please use our **DYNALOG (DYNAPLAN)** planning software for all your planning needs.

Page instructions

Overview – TANDEMBOX antaro	263	Cabinet profile fixing positions	306
Overview – SERVO-DRIVE for TANDEMBOX	367	Assembly, removal and adjustment	365
Overview – TIP-ON for TANDEMBOX	407	Overview – assembly devices	605
Overview – ORGA-LINE for TANDEMBOX	561	More technical details	684
Accessories – design element	300		
Cutting dimensions design element D high	281		
Accessories	300		

Box systems

- ▶ TANDEMBOX antaro
- ▶▶ Sink cabinet



High fronted pull-out – gallery – C



- With simple gallery
- Design element possible
- Concealed, guided full extension
- TANDEM inside – unsurpassed running action – for the lifetime of the furniture
- Drawer sides made from steel silk white (SW), terra black (TS), RAL 9006 grey (white aluminium, R9006) and stainless steel (Inox)
- Tool-free front assembly
- 3-dimensional front adjustment
- Includes integrated **BLUMOTION** for silent and effortless closing action, can be combined with **SERVO-DRIVE**
- Or with an integrated **TIP-ON** function for handle-less fronts

Space requirement

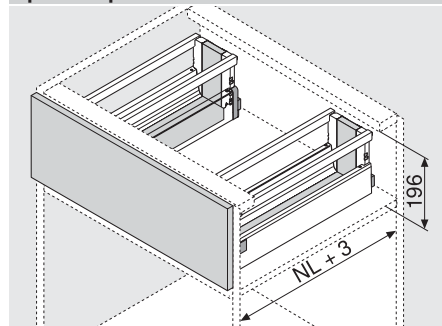

NL Nominal length

Order information

1	Cabinet profiles left/right		Cabinet profiles left/right	2	Drawer sides and cover caps left/right	11	Sink drawer side left/right				
	BLUMOTION *						TIP-ON **	SW	TS	R9006	Inox
Nominal length NL	30 kg		50 kg	SW	TS	R9006	Inox	SW	TS	R9006	Inox
450 mm	558.4501B01		559.4501T	358M4502SA	358M4502IA	358M4504SG	358M4504IG	358M4504SG	358M4504IG		
500 mm	558.5001B		559.5001T	358M5002SA	358M5002IA	358M5004SG	358M5004IG	358M5004SG	358M5004IG		
550 mm	558.5501B		559.5501T	358M5502SA	358M5502IA	358M5504SG	358M5504IG	358M5504SG	358M5504IG		
600 mm			559.6001T	359M6002SA	359M6002IA	358M6004SG	358M6004IG	358M6004SG	358M6004IG		
650 mm			559.6501T	359M6502SA	359M6502IA	358M6504SG	358M6504IG	358M6504SG	358M6504IG		

* Suitable for SERVO-DRIVE

** Order specification, see TIP-ON for TANDEMBOX

8	Longside gallery rail left/right				
	Nominal length NL	SW	TS	R9006	Inox
450 mm	2 x	ZRG.387RSIC	ZRG.387RIIC		
500 mm	2 x	ZRG.437RSIC	ZRG.437RIIC		
550 mm	2 x	ZRG.487RSIC	ZRG.487RIIC		
600 mm	2 x	ZRG.537RSIC	ZRG.537RIIC		
650 mm	2 x	ZRG.587RSIC	ZRG.587RIIC		

3	Back fixing left/right		
	Material	Colour	Part no.
	Steel	SW, TS, R9006, NI	2 x Z30C000S

4	Front fixing bracket		
	Fixing method		Part no.
	INSERTA	2 x	ZSF.3902
	Screw-on	2 x	ZSF.3502
	Knock-in	2 x	ZSF.3602

12	Back fixing left/right		
	Material	Colour	Part no.
	Steel	SW, TS, R9006, NI	Z30N000S.04

13	Adapter left/right		
	Material	Colour	Part no.
	Nylon	R7037	Z30N0002.6Z

a Accessories			
9	Locking piece set		
	Material	Colour	Part no.
	Nylon	SW, S, WGR, R7037	Z36C0080

9a	Design element (side)		
	Material	Colour	Part no.
	Glass	Clear, frosted	2 x Z37Rxx7C
	Metal	SW, TS, R9006	2 x Z37Axx7C

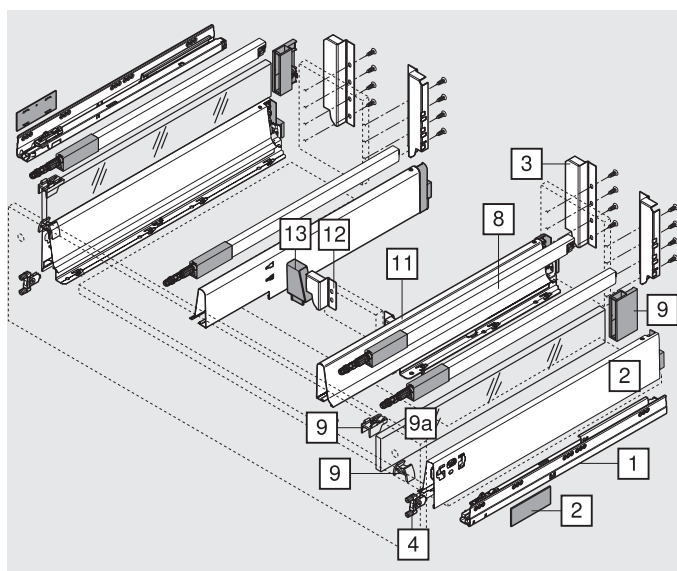

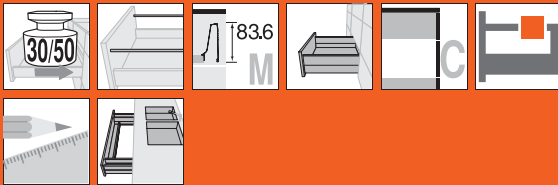

High fronted pull-out – gallery – C

Planning

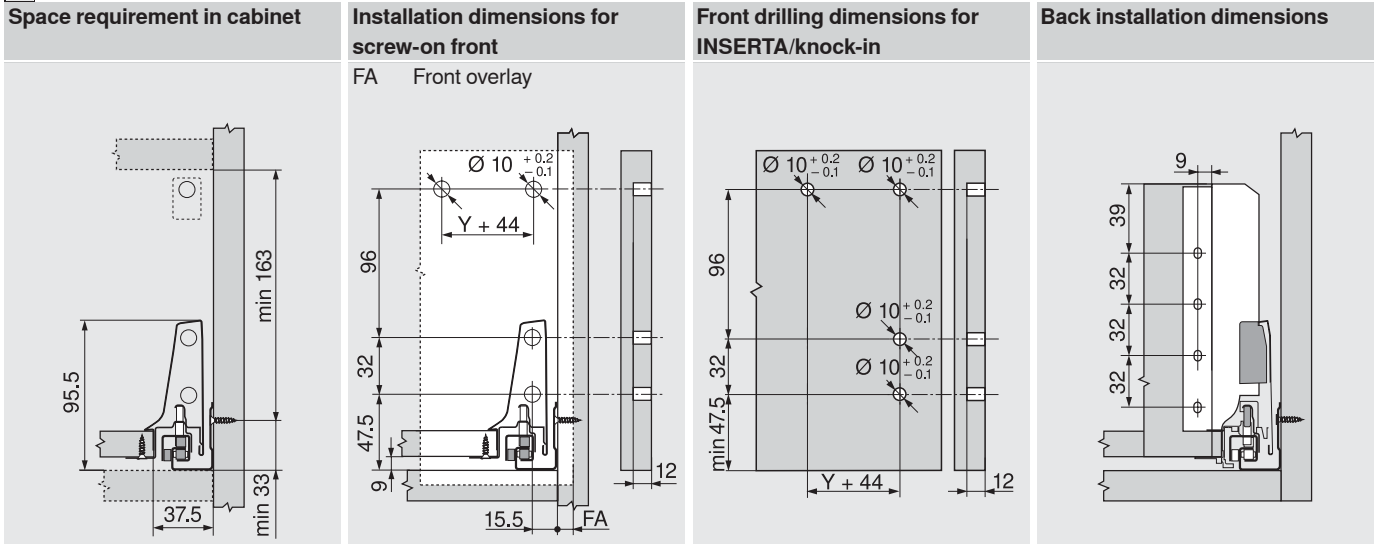

Cabinet profile screw positions

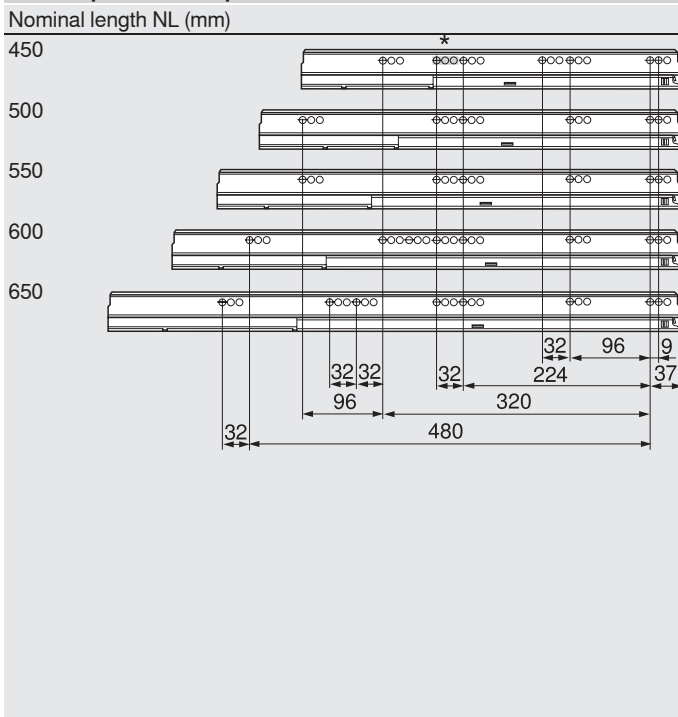

Min. internal cabinet depth = nominal length NL + 3 mm

* Only for 558.4501B01 (30 kg)

Divider dimensions

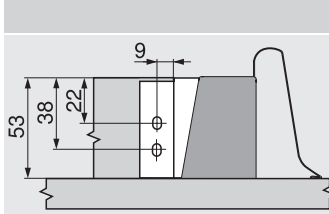

Cutting dimensions for 16 mm chipboard

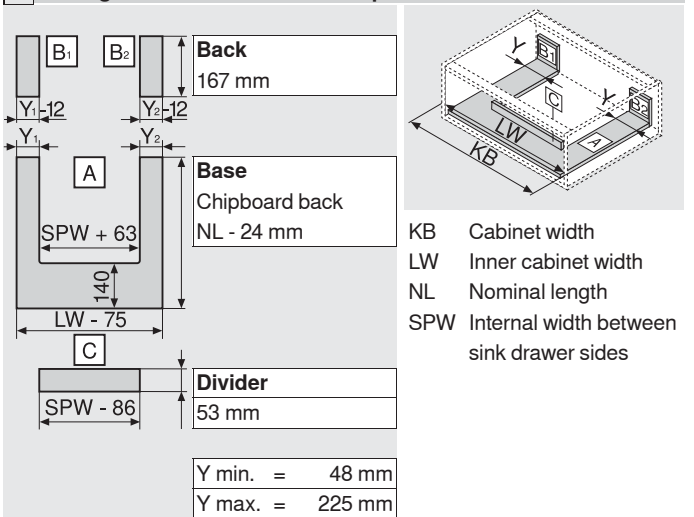

Page instructions

Overview – TANDEMBOX antaro	263	Cabinet profile fixing positions	306
Overview – SERVO-DRIVE for TANDEMBOX	367	Assembly, removal and adjustment	308
Overview – TIP-ON for TANDEMBOX	407	Overview – assembly devices	605
Overview – ORGA-LINE for TANDEMBOX	561	More technical details	684
Accessories – design element	300		
Cutting dimensions design element C high	276		
Accessories	300		

Box systems

- ▶ TANDEMBOX antaro
- ▶▶ Sink cabinet



High fronted pull-out – gallery – D



- With simple gallery
- Design element possible
- Concealed, guided full extension
- TANDEM inside – unsurpassed running action – for the lifetime of the furniture
- Drawer sides made from steel silk white (SW), terra black (TS), RAL 9006 grey (white aluminium, R9006) and stainless steel (Inox)
- Tool-free front assembly
- 3-dimensional front adjustment
- Includes integrated **BLUMOTION** for silent and effortless closing action, can be combined with **SERVO-DRIVE**
- Or with an integrated **TIP-ON** function for handle-less fronts

Space requirement

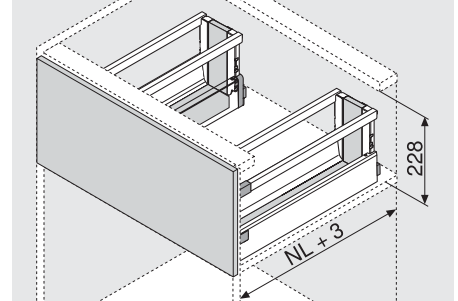

NL Nominal length

Order information

1	Cabinet profiles left/right		Cabinet profiles left/right	2	Drawer sides and cover caps left/right	11	Sink drawer side left/right			
	BLUMOTION *						TIP-ON **	SW	TS R9006	R9006
Nominal length NL	30 kg		50 kg	SW	TS R9006	Inox	SW	TS R9006	R9006	Inox
450 mm	558.4501B01		559.4501T	358M4502SA	358M4502IA	358M4504SG	358M4504IG			
500 mm	558.5001B		559.5001T	358M5002SA	358M5002IA	358M5004SG	358M5004IG			
550 mm	558.5501B		559.5501T	358M5502SA	358M5502IA	358M5504SG	358M5504IG			
600 mm		559.6001B	559.6001T	359M6002SA	359M6002IA	358M6004SG	358M6004IG			
650 mm		559.6501B	559.6501T	359M6502SA	359M6502IA	358M6504SG	358M6504IG			

* Suitable for SERVO-DRIVE

** Order specification, see TIP-ON for TANDEMBOX

8	Longside gallery rail left/right			
	Nominal length NL	SW	TS R9006	Inox
450 mm	2 x	ZRG.387RSIC	ZRG.387RIIC	
500 mm	2 x	ZRG.437RSIC	ZRG.437RIIC	
550 mm	2 x	ZRG.487RSIC	ZRG.487RIIC	
600 mm	2 x	ZRG.537RSIC	ZRG.537RIIC	
650 mm	2 x	ZRG.587RSIC	ZRG.587RIIC	

3	Back fixing left/right		
	Material	Colour	Part no.
	Steel	SW, TS, R9006, NI	2 x Z30D000SL

4	Front fixing bracket	
	Fixing method	Part no.
	INSERTA	2 x ZSF.3902
	Screw-on	2 x ZSF.3502
	Knock-in	2 x ZSF.3602

12	Back fixing left/right		
	Material	Colour	Part no.
	Steel	SW, TS, R9006, NI	Z30N000S.04

13	Adapter left/right		
	Material	Colour	Part no.
	Nylon	R7037	Z30N0002.6Z

9	Accessories		
	Locking piece set		
Material	Colour	Part no.	
Nylon	SW, S, WGR, R7037	Z36D0080	

9a	Design element (side)		
	Material	Colour	Part no.
Glass	Clear, frosted	2 x	Z37Rxx7D
Metal	SW, TS, R9006	2 x	Z37Axx7D

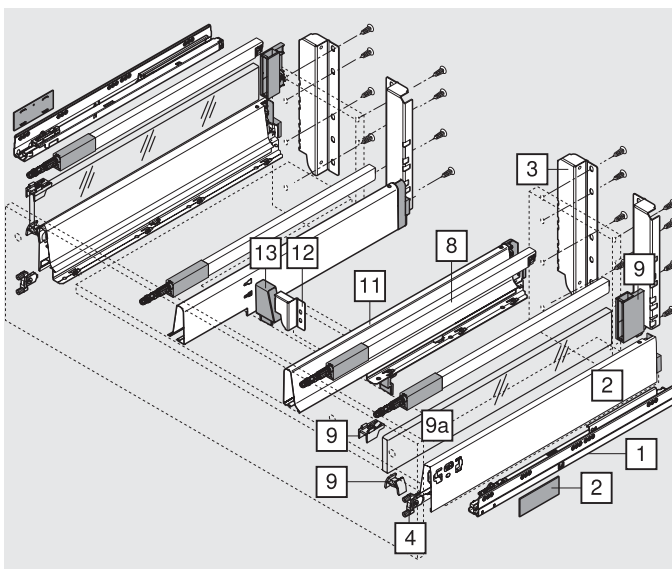



High fronted pull-out – gallery – D

Planning

Space requirement in cabinet	Installation dimensions for screw-on front	Front drilling dimensions for INSERTA/knock-in	Back installation dimensions
	<p>FA Front overlay</p>		

Cabinet profile screw positions

Nominal length NL (mm)

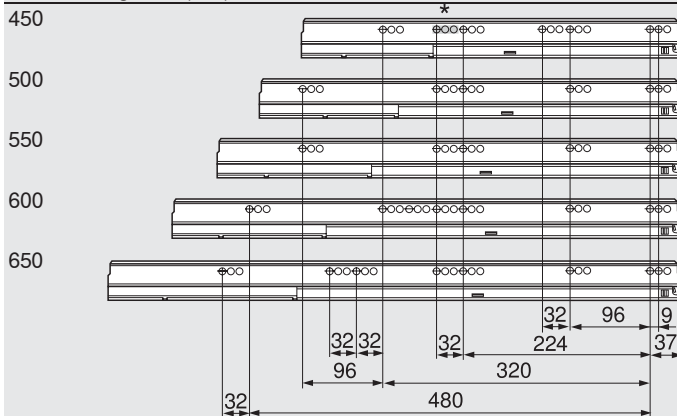

Min. internal cabinet depth = nominal length NL + 3 mm

* Only for 558.4501B01 (30 kg)

Divider dimensions

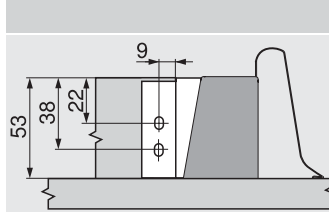

Cutting dimensions for 16 mm chipboard

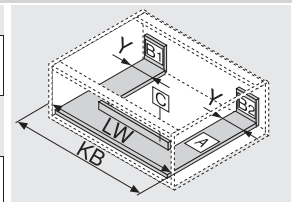
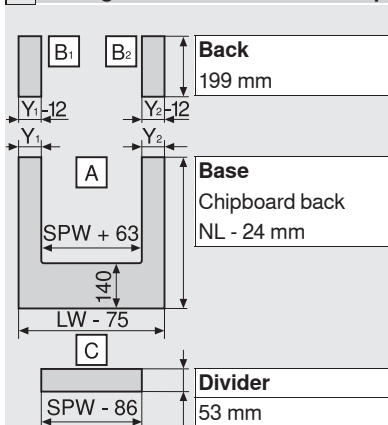

KB Cabinet width
LW Inner cabinet width
NL Nominal length
SPW Internal width between sink drawer sides

Y min. = 48 mm

Y max. = 225 mm

Page instructions

Overview – TANDEMBOX antaro	263	Cabinet profile fixing positions	306
Overview – SERVO-DRIVE for TANDEMBOX	367	Assembly, removal and adjustment	308
Overview – TIP-ON for TANDEMBOX	407	Overview – assembly devices	605
Overview – ORGA-LINE for TANDEMBOX	561	More technical details	684
Accessories – design element	300		
Cutting dimensions design element D high	281		
Accessories	300		

Box systems



- ▶ TANDEMBOX antaro
- ▶▶ Larder unit

SPACE TOWER



- The larder unit is equipped with inner drawers, with shelves in the upper section
- Enough space and plenty of stability, even for large and bulky items
- ORGA-LINE inner dividing systems for pull-outs puts everything in order and allows easy access
- Up to 55 % more storage space through the use of higher back and side walls
- Allows access from all sides
- Includes integrated **BLUMOTION** for silent and effortless closing action, can be combined with **SERVO-DRIVE**
- Or with an integrated **TIP-ON** function for handle-less fronts



Order information

Inner pull-out		Application recommendation	
Inner pull-out		278	
ORGA-LINE		572	
Inner pull-out		282	
ORGA-LINE		572	

Front	
CLIP top 155° hinge	110

Recommended cabinet widths: 450 - 600 mm

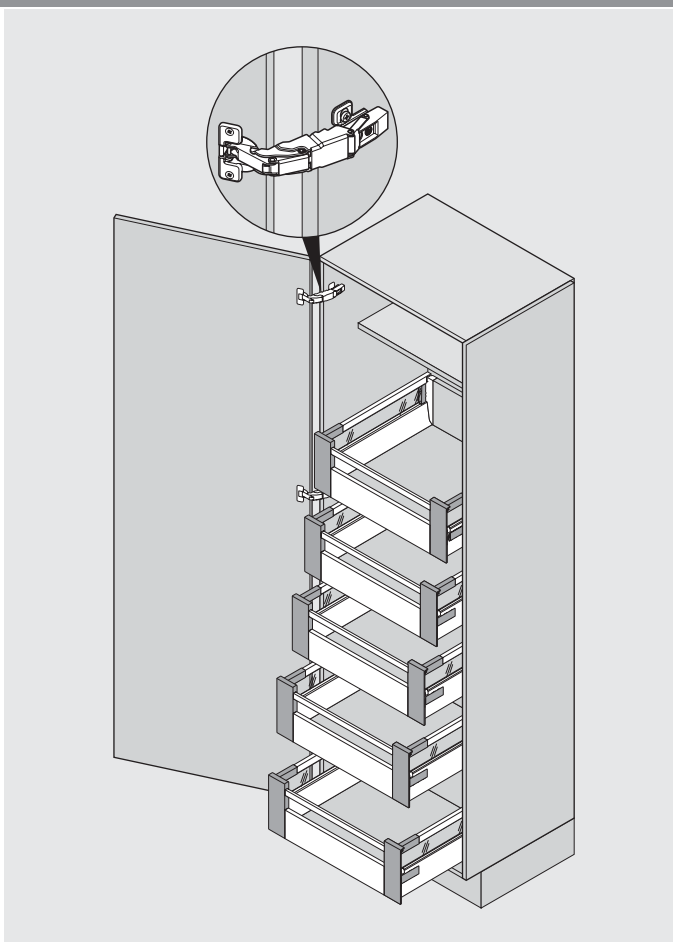

Page instructions

Overview – TANDEMBOX antaro	263	Assembly, removal and adjustment	308
Overview – SERVO-DRIVE for TANDEMBOX		Overview – assembly devices	605
	367	More technical details	684
Overview – TIP-ON for TANDEMBOX			
	407		
Overview – ORGA-LINE for TANDEMBOX			
	561		
CLIP top 155° hinge	110		
Accessories – BLUMOTION for doors	182		
Accessories	300		

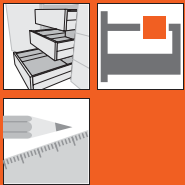

SPACE TOWER

Planning

Space requirement in cabinet

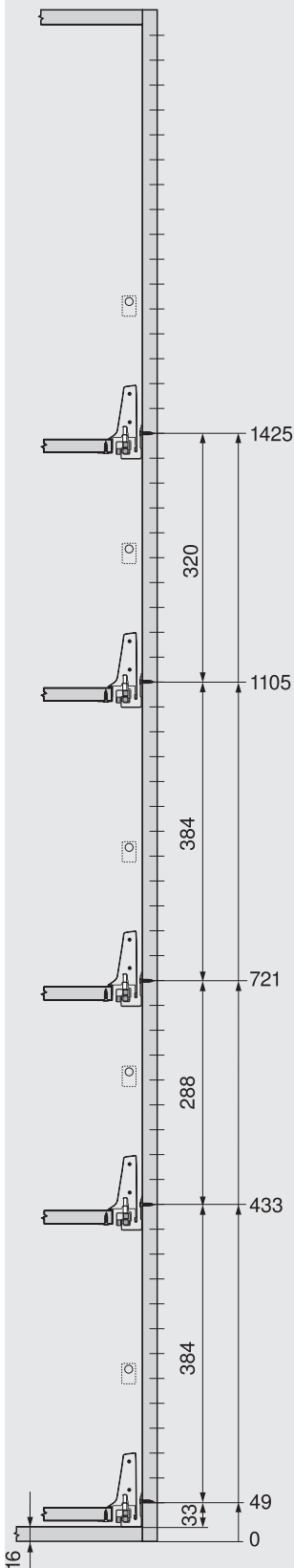

Front drilling dimensions

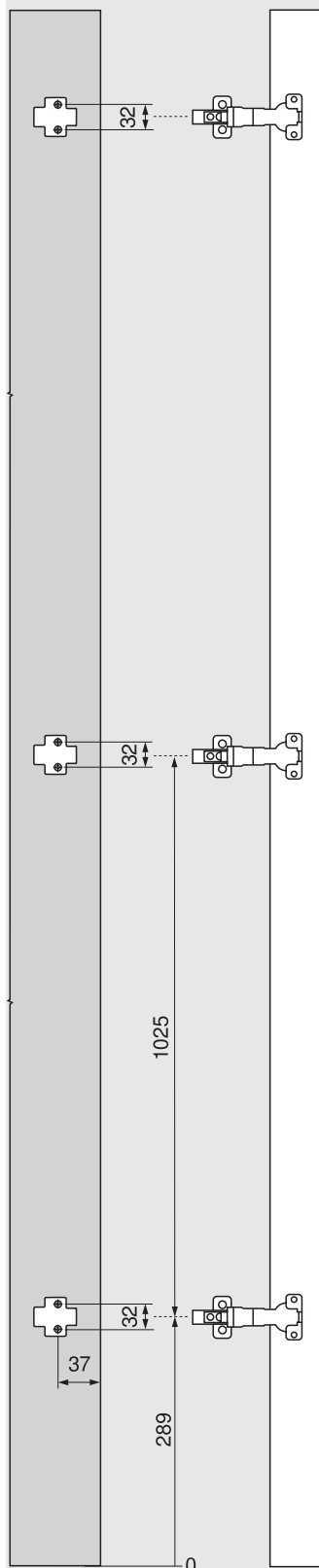

All dimensions are aligned with the 32 mm system.

Please use our **DYNALOG (DYNAPLAN)** planning software for all your planning needs.

1st system drilling used for cabinet base 16 mm and bottom gap = 0 mm.

Page instructions

Number of Hinges

692

Box systems



- ▶ TANDEMBOX antaro
- ▶▶ Accessories

Glass design element



- Create closed containers and give your kitchen character
- Glass, frosted or clear

Page instructions	
Overview – TANDEMBOX antaro	263
Cutting dimensions design element C height	276
Cutting dimensions design element D height	281
Assembly, removal and adjustment	310
Overview – assembly devices	605
More technical details	684

Cutting	
Nominal length NL - 33 mm	

Order information

Glass design element (side)		Glass design element (side)	
C height		D height	
Nominal length NL	Clear Frosted	Nominal length NL	Clear Frosted
270 mm	Z37R237C	270 mm	Z37R237D
300 mm	Z37R267C	300 mm	Z37R267D
350 mm	Z37R317C	350 mm	Z37R317D
400 mm	Z37R367C	400 mm	Z37R367D
450 mm	Z37R417C	450 mm	Z37R417D
500 mm	Z37R467C	500 mm	Z37R467D
550 mm	Z37R517C	550 mm	Z37R517D
600 mm	Z37R567C	600 mm	Z37R567D
650 mm	Z37R617C	650 mm	Z37R617D

Metal design element



- Create closed containers and give your kitchen character
- Material: aluminium
- For cutting to size

Page instructions	
Overview – TANDEMBOX antaro	263
Cutting dimensions design element C height	276
Cutting dimensions design element D height	281
Assembly, removal and adjustment	310
Overview – assembly devices	605
More technical details	684

Cutting	
Nominal length NL - 33 mm	

Order information

Metal design element (side)		Metal design element (side)	
C height		D height	
Nominal length NL	SW TS R9006	Nominal length NL	SW TS R9006
450 mm	Z37A417C	450 mm	Z37A417D
500 mm	Z37A467C	500 mm	Z37A467D
550 mm	Z37A517C	550 mm	Z37A517D
650 mm	Z37A617C	650 mm	Z37A617D

Steel back

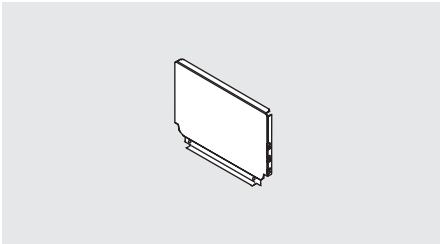

- For TANDEMBOX
- Material: steel
- Colour: silk white, terra black, RAL 9006 grey (white aluminium), nickel plated

Back height	Part no.
N height	Z30NxxxS.6
M height	Z30MxxxS.6
K height	Z30KxxxS.6
C height	Z30CxxxS.6
D height	Z30DxxxS.6

Planning

Calculation of width

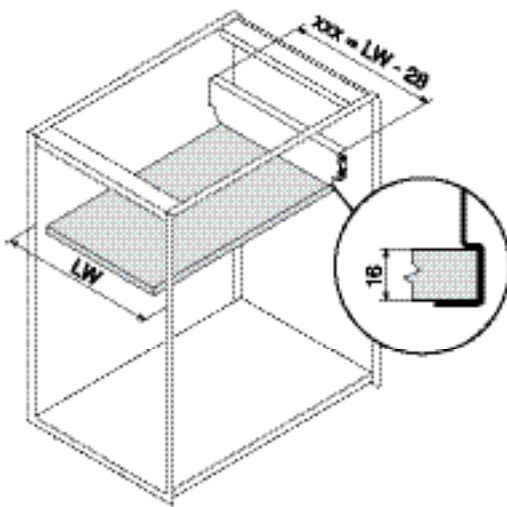

xxx Back width

Example:

Internal cabinet width 567 mm - 28 mm = back width 539 mm

Order: **Z30M539S.6** in white

Cutting dimensions for 16 mm chipboard

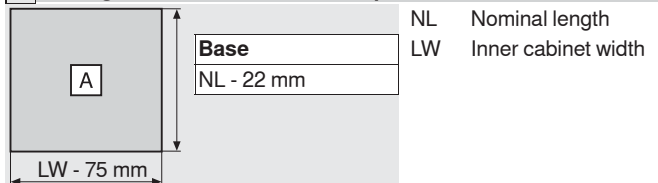

Back fixing B height

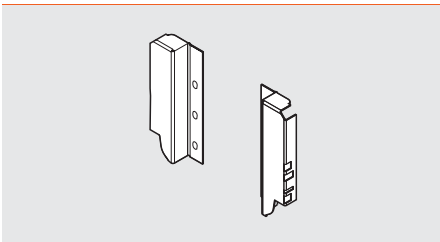

- For TANDEMBOX
- Material: steel
- Colour: silk white, terra black, RAL 9006 grey (white aluminium), nickel plated

Back fixing B height	Part no.
	Z30B000S.04

Cutting

Back height	135 mm
-------------	--------

Planning

Space requirement in cabinet

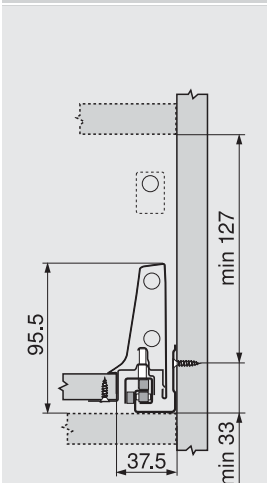

Installation dimensions for screw-on front

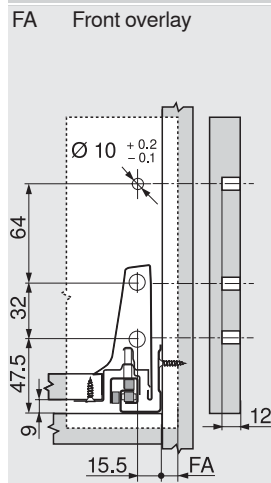

Back installation dimensions

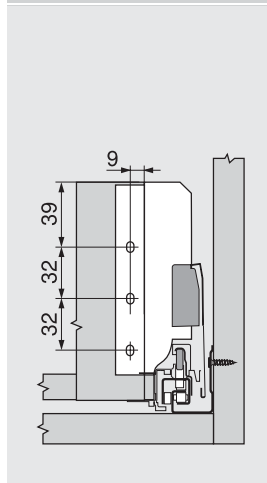

Box systems



- ▶ TANDEMBOX antaro
- ▶▶ Accessories

Flexible gallery fixing

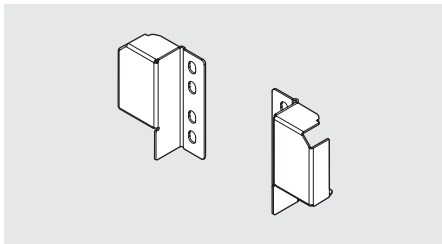

- Material: steel
- Colour: silk white, terra black, RAL 9006 grey (white aluminium), nickel plated

	Part no.
Flexible gallery fixing	ZRR.5200

Planning

Space requirement in cabinet	Installation dimensions for screw-on front	Back installation dimensions
Free placement Y = X - 4 mm X Back height	Free placement Z = X - 71 mm X Back height FA Front overlay	Free placement W = X - 103 mm X Back height

Space requirement in cabinet	Installation dimensions for screw-on front	Back installation dimensions
Height D – double gallery (back fixing bracket height B)	Height D – double gallery (back fixing bracket height B) FA Front overlay	Height D – double gallery (back fixing bracket height B)

Side stabilisation – top mounted

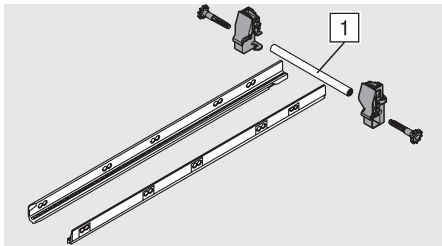
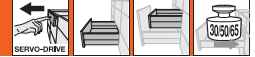

- Additional stabilisation for extra wide high fronted pull-outs
- Recommendation: cabinet width 900 to 1200 mm
- Aluminium rod suitable for KB 1200 mm, for cutting to size
- Suitable for use with SERVO-DRIVE

Cutting	
1	Internal cabinet width LW - 86 mm

Nominal length NL	Part no.
450 mm	ZST.450BA
500 mm	ZST.500BA
550 mm	ZST.550BA
600 mm	ZST.600BA
650 mm	ZST.650BA
Page instructions	
Fixing for side stabilisation	307

Planning

Space requirement in cabinet

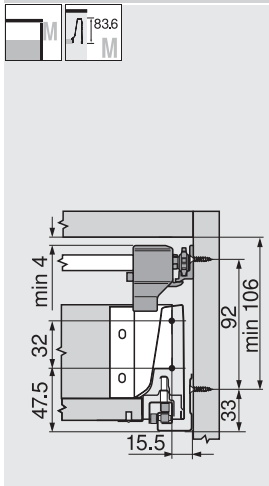

Space requirement in cabinet

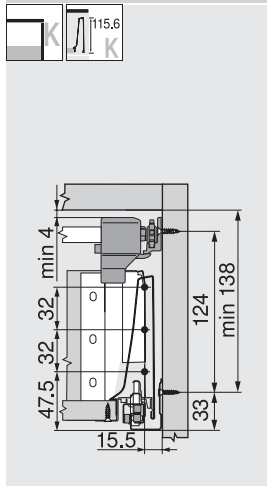

Space requirement in cabinet

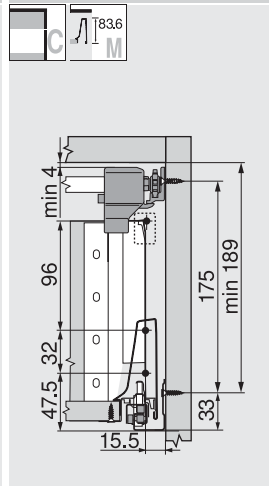

Space requirement in cabinet

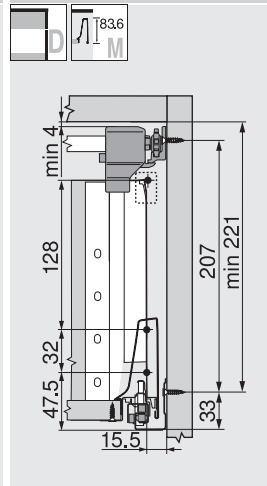

Assembly

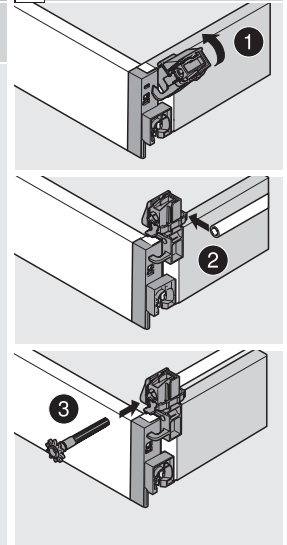

Front stabilisation

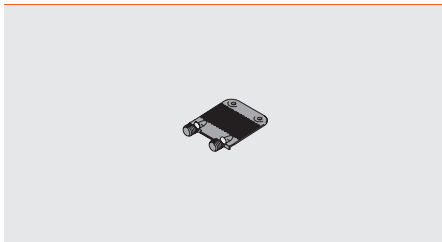

- For stabilising wide and high fronts
- Reinforces the connection between the drawer side and the front
- Material: nylon, RAL 7037 light grey

Part no.	
Front stabilisation	Z96.10E1

Planning

Space requirement in cabinet

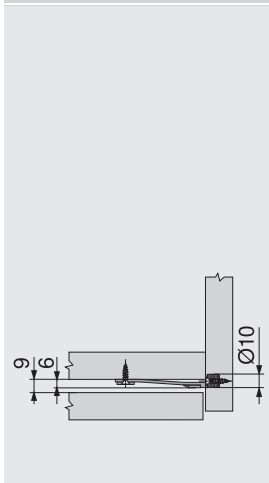

Front drilling dimensions

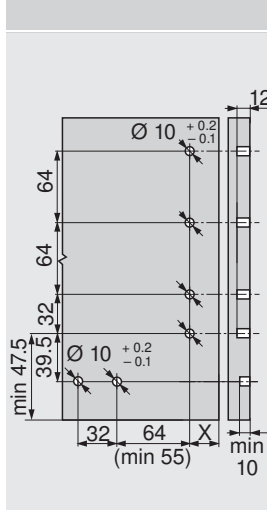

Box systems



- ▶ TANDEMBOX antaro
- ▶▶ Accessories

Chipboard screws

Ø 3.5 mm

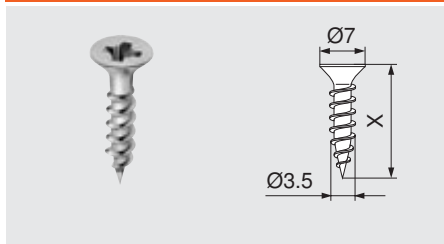

- Ø 3.5 mm
- Material: steel, nickel plated

Length (X)	Part no.
15 mm	609.1500
17 mm	609.1700

System screws

Ø 6.0 mm

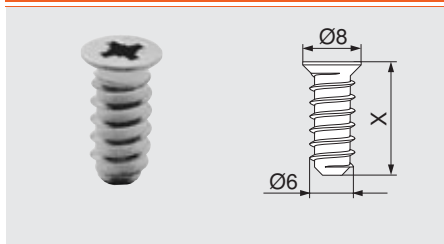

- Ø 6 mm
- Drilling diameter Ø 5 mm
- Material: steel, nickel plated

Length (X)	Part no.
10 mm	661.1000.HG
11.5 mm	661.1150.HG
13 mm	661.1300.HG
14.5 mm	661.1450.HG
20 mm	661.2000.HG

Special system screws

Ø 6.0 mm

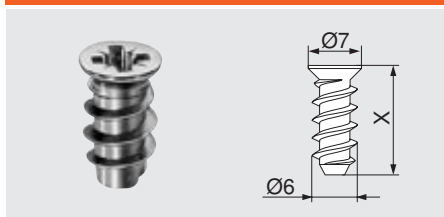

- Ø 6 mm
- Drilling diameter Ø 5 mm
- Material: steel, nickel plated

Length (X)	Part no.
11.5 mm	662.1150.HG
13 mm	662.1300.HG
14.5 mm	662.1450.HG

Centre bit



- Ø 2.7 mm, length 70 mm
- To pre-drill for Ø 3.5 mm chipboard screws
- Drilling depth up to 8 mm
- Material: steel, hardened

	Part no.
Centre bit	M01.ZZ03
Replacement bit	M01.ZZB3

Stick-on door buffer

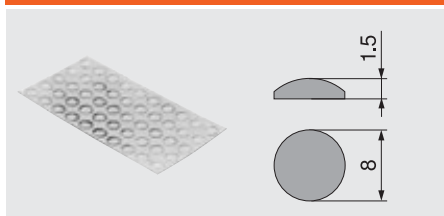

- For noise reduction
- Material: nylon, natural coloured

	Part no.
Stick-on door buffer	993.710

8 mm Ø door buffer

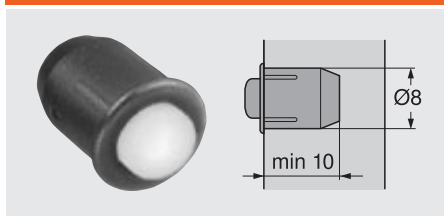

- For noise reduction
- Gap 2 mm
- Two-part
- Material: nylon, RAL 9006 white aluminium

	Part no.
8 mm Ø door buffer	993.706



Pozidrive screwdriver



- PZ (Pozi) size 2
- Blade length 100 mm
- Overall length 200 mm
- Orange handle with Blum logo
- Material: nylon/steel, black/orange

	Part no.
Pozidrive screwdriver	303.756.1

Slotted screwdriver

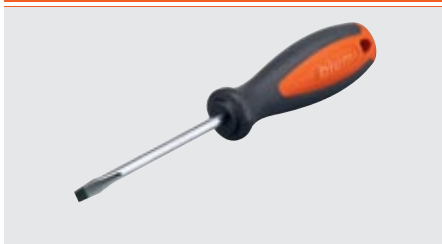

- Slotted, size 1.0 x 5.5 mm
- Blade length 125 mm
- Overall length 225 mm
- Orange handle with Blum logo
- Material: nylon/steel, black/orange

	Part no.
Slotted screwdriver	314.928.1

Box systems



- ▶ TANDEMBOX antaro
- ▶▶ Cabinet profile fixing positions

Box systems

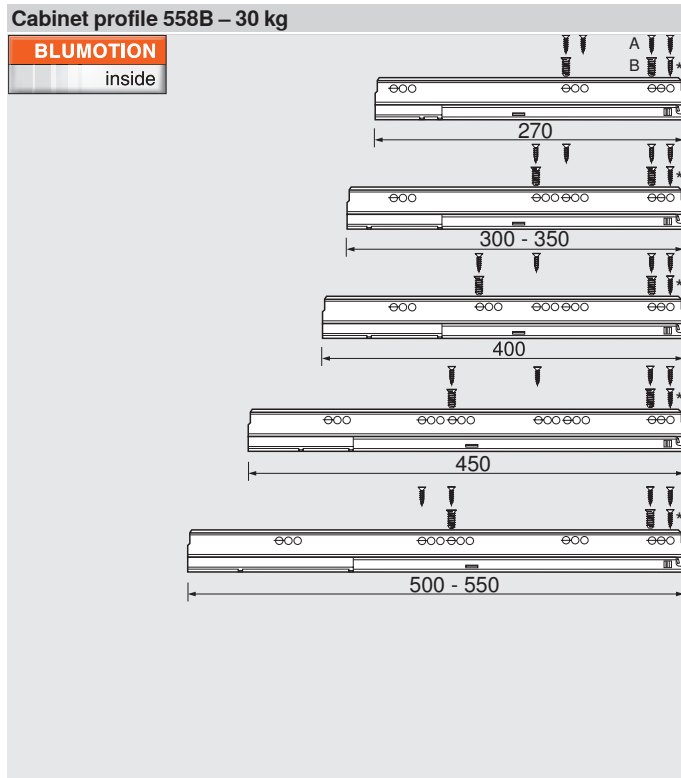

Fixing onto cabinet

- A Chipboard screws \varnothing 4 x 15 mm
- B Chipboard screws, part no. 661.1450.HG
- * Optional

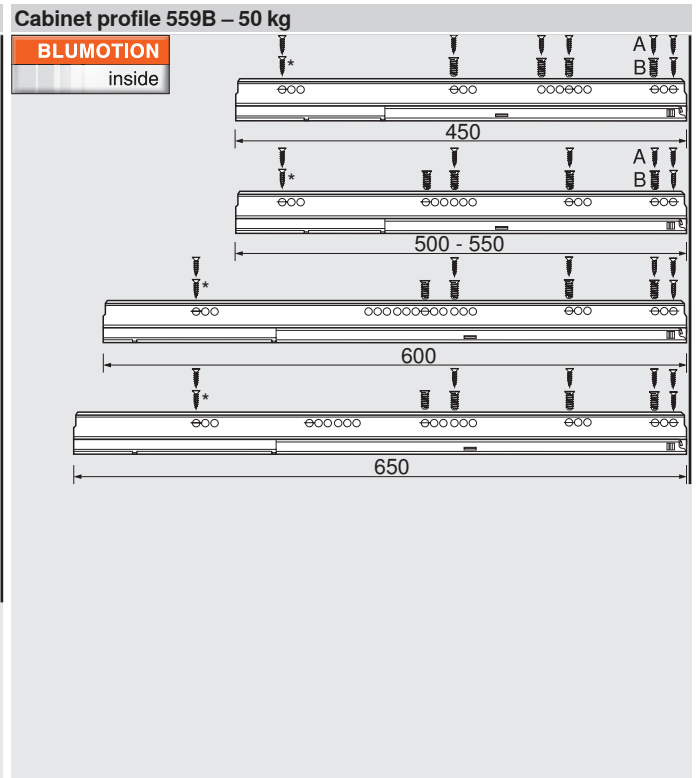

Fixing onto cabinet

- A Chipboard screws \varnothing 4 x 15 mm
- B Chipboard screws, part no. 661.1450.HG
- * Optional

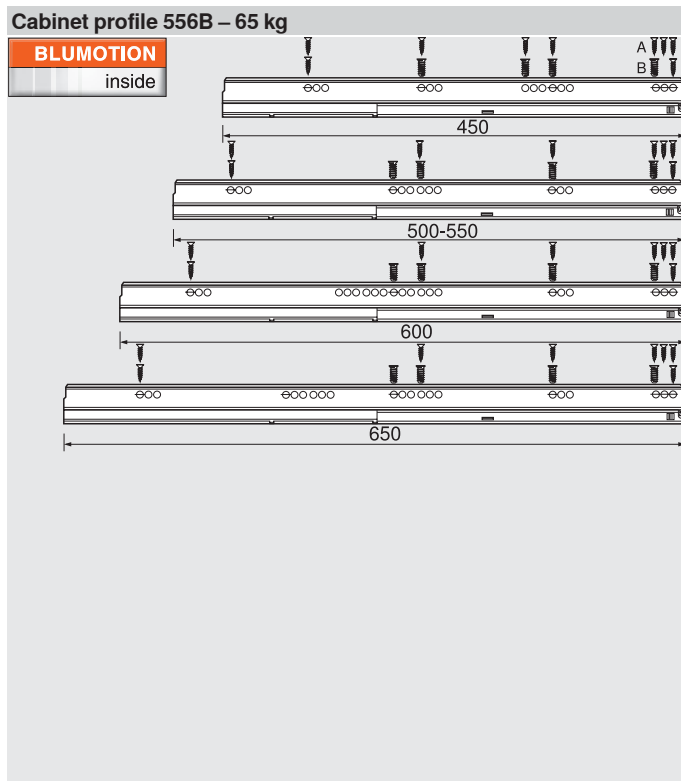

Fixing onto cabinet

- A Chipboard screws \varnothing 4 x 15 mm
- B Chipboard screws, part no. 661.1450.HG

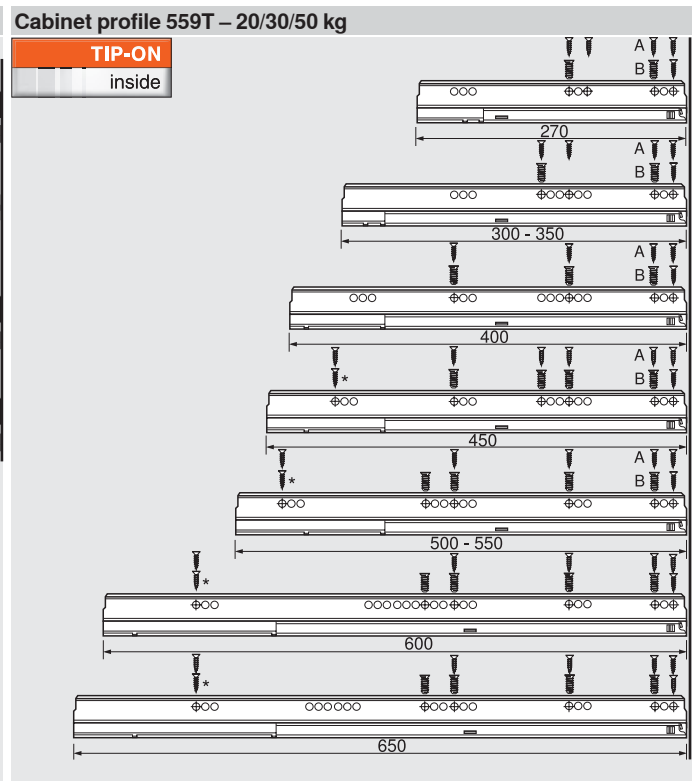

Fixing onto cabinet

- A Chipboard screws \varnothing 4 x 15 mm
- B Chipboard screws, part no. 661.1450.HG
- * Optional



Side stabilisation – top mounted

Nominal length NL (mm)

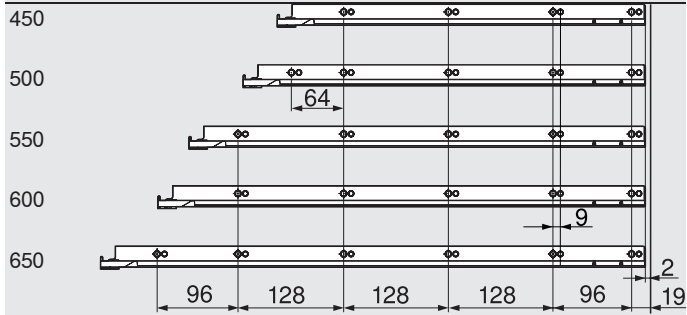

Min. internal cabinet depth = nominal length NL + 3 mm

Box systems



- ▶ TANDEMBOX antaro
- ▶▶ Assembly, removal and adjustment

Drawer

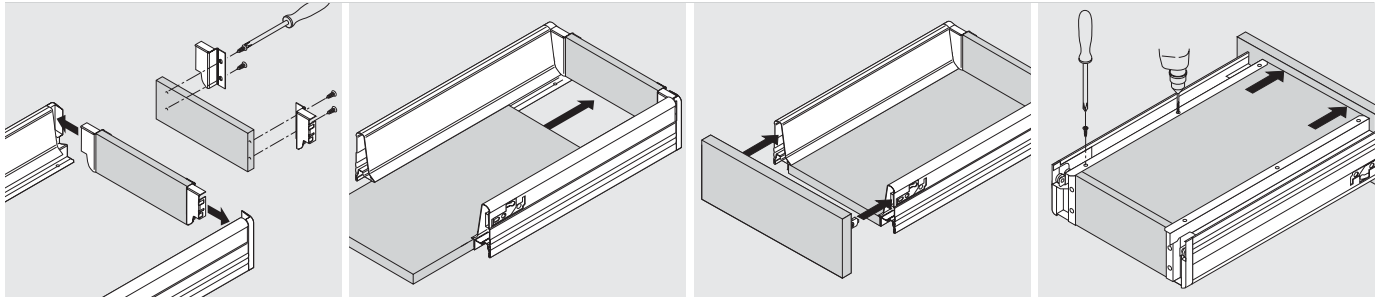

Assembly

Drawer

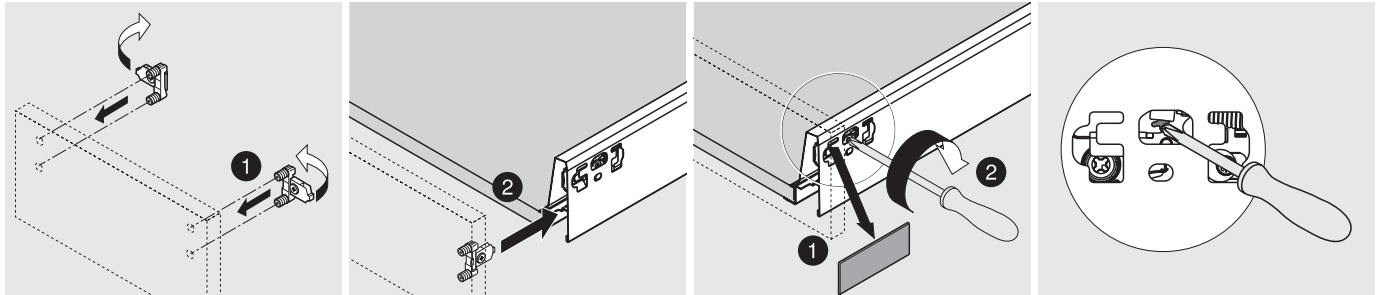

Assembly

Removal

Adjustment

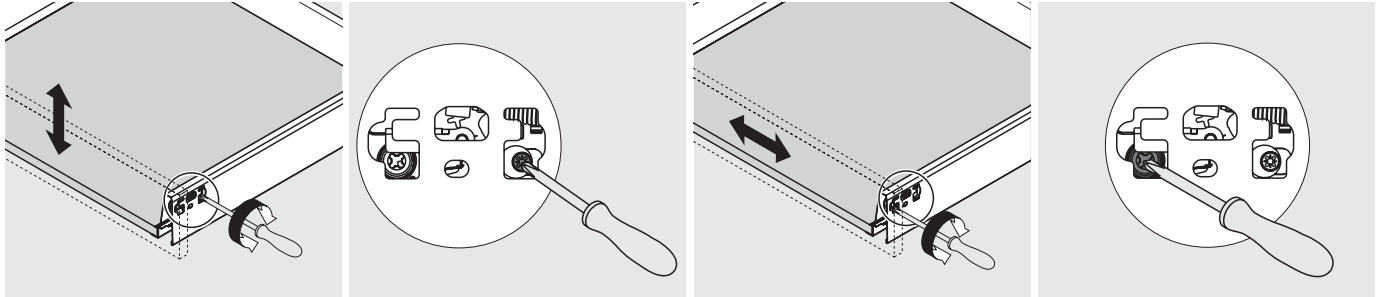

Height adjustment

Side adjustment

Adjustment

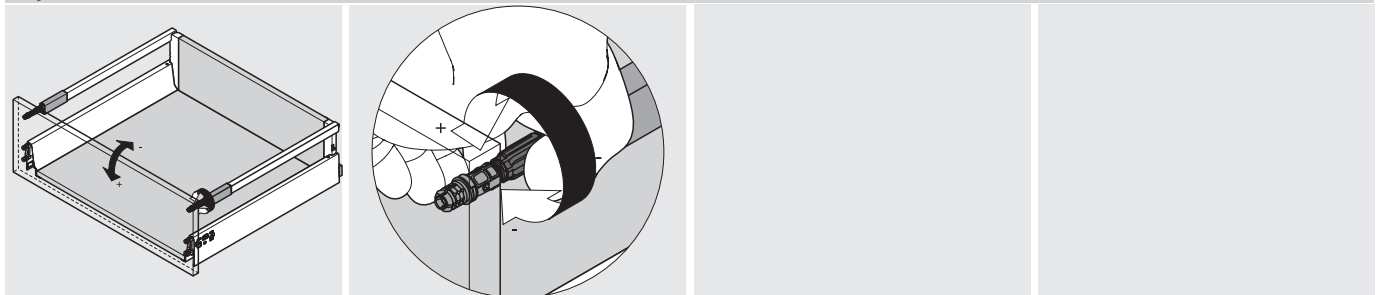

Tilt adjustment



Drawer insertion and removal

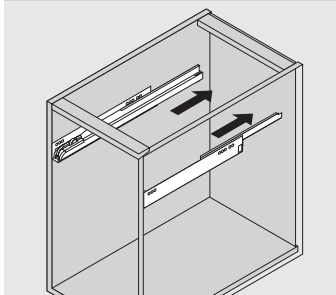

Insertion

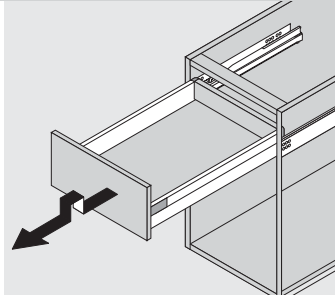
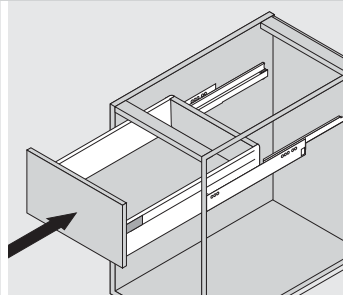

Removal

Inner drawer

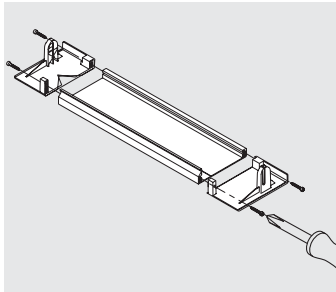

Assembly

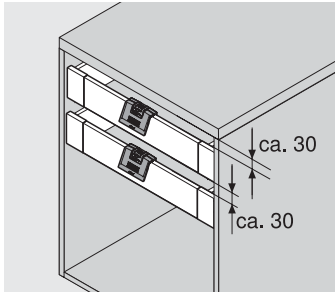
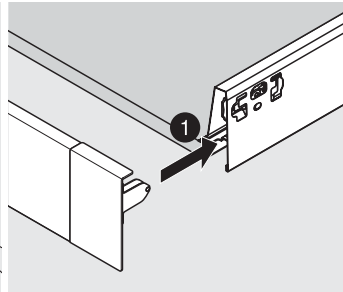

30 mm dimension can be reduced if ZIF.80M5 handle is utilised

Locking piece – Z31A0008

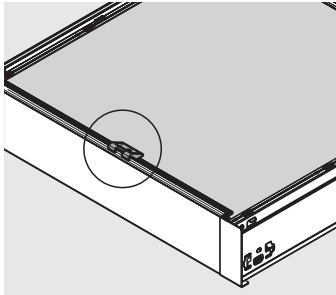

Starting with cabinet width KB
600 mm

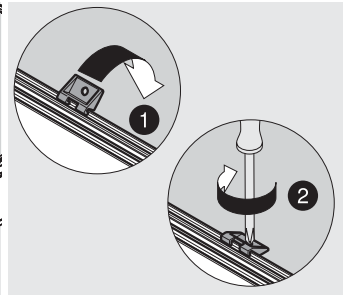

Inner drawer

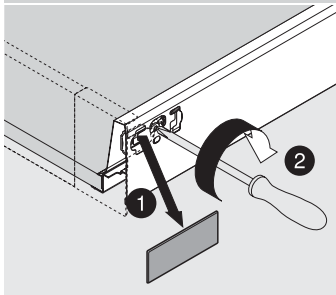

Removal

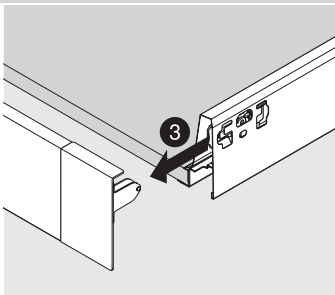
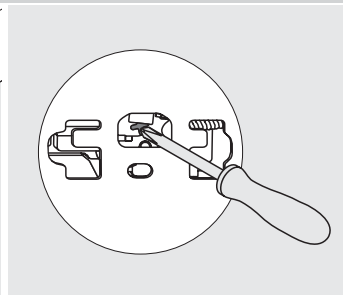

Box systems



- ▶ TANDEMBOX antaro
- ▶▶ Assembly, removal and adjustment

Handle and latch

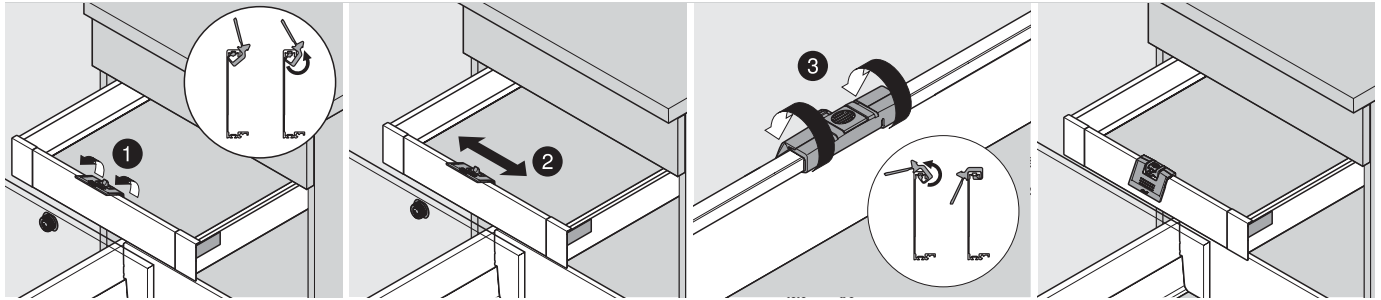

Assembly

Attached to the centre on the latch

Handle and latch

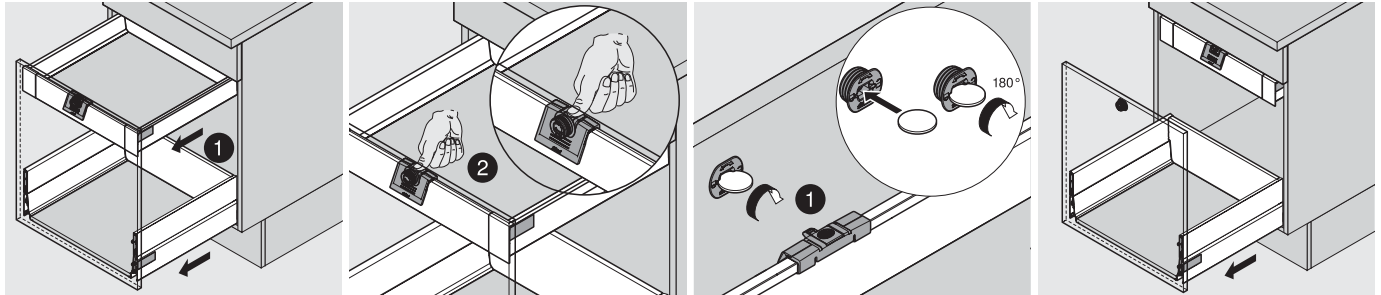

Latch is activated

Released when latch is activated

Activate or deactivate latch

High fronted pull-out

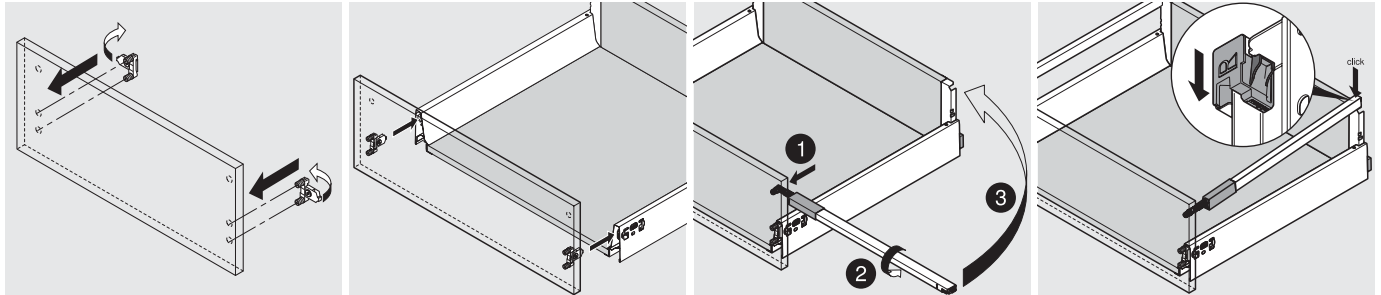

Assembly

High fronted pull-out – design element

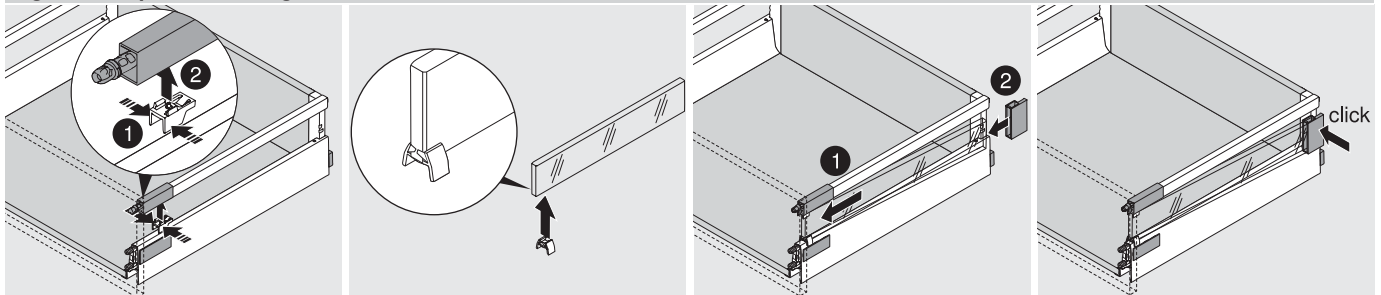

Assembly



High fronted pull-out – design element

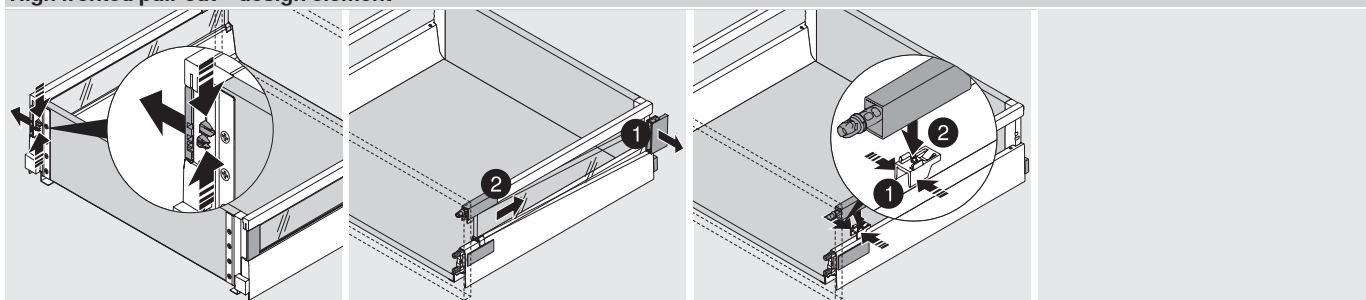

Removal

High fronted pull-out

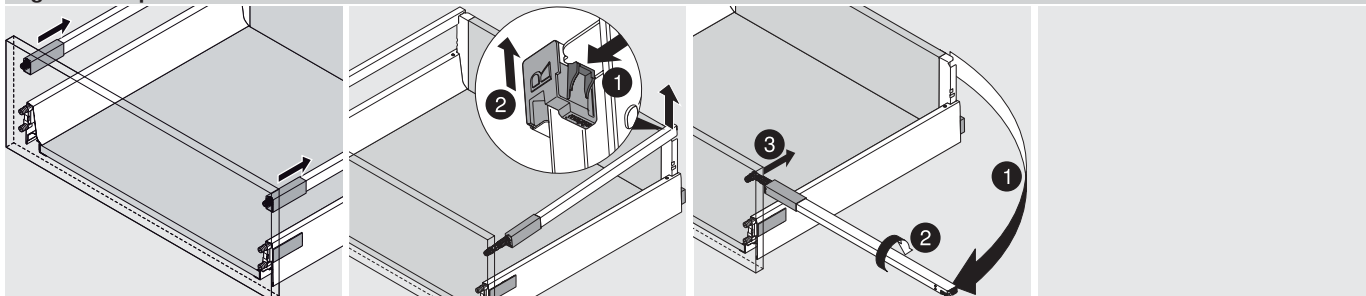

Removal

High fronted pull-out

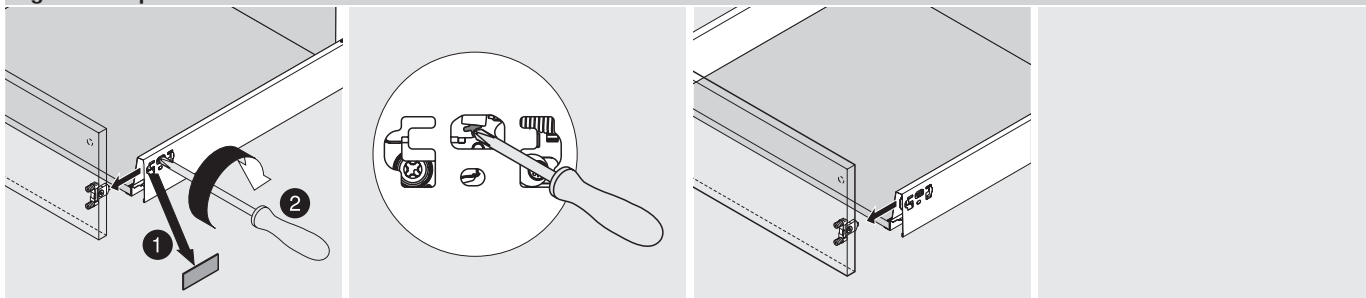

Inner pull-out

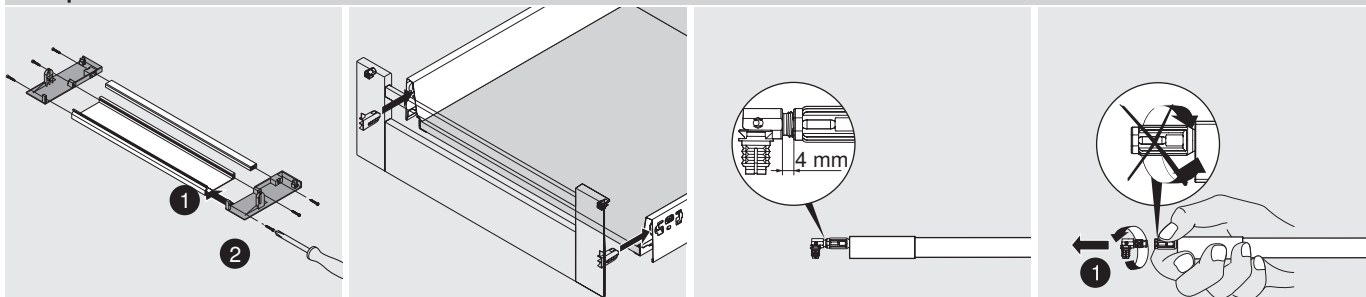

Box systems



- ▶ TANDEMBOX antaro
- ▶▶ Assembly, removal and adjustment

Inner pull-out

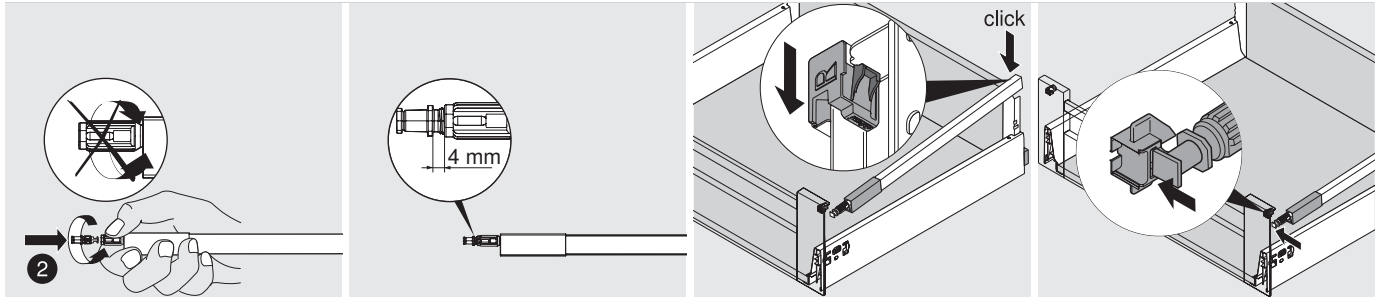

Inner pull-out

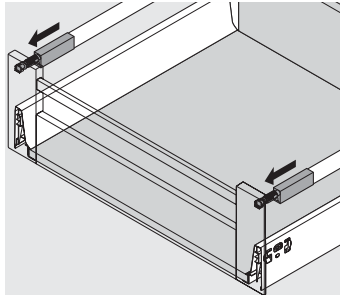

Locking piece – Z31A0008

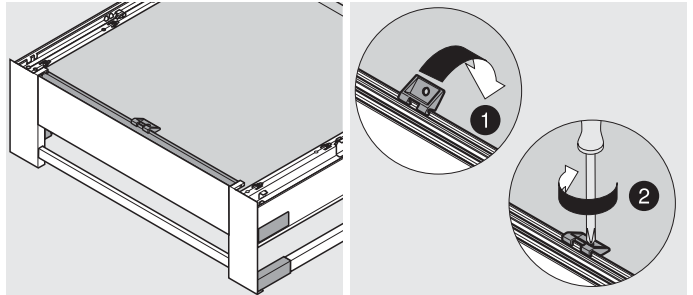

Starting with cabinet width KB
600 mm

Inner pull-out

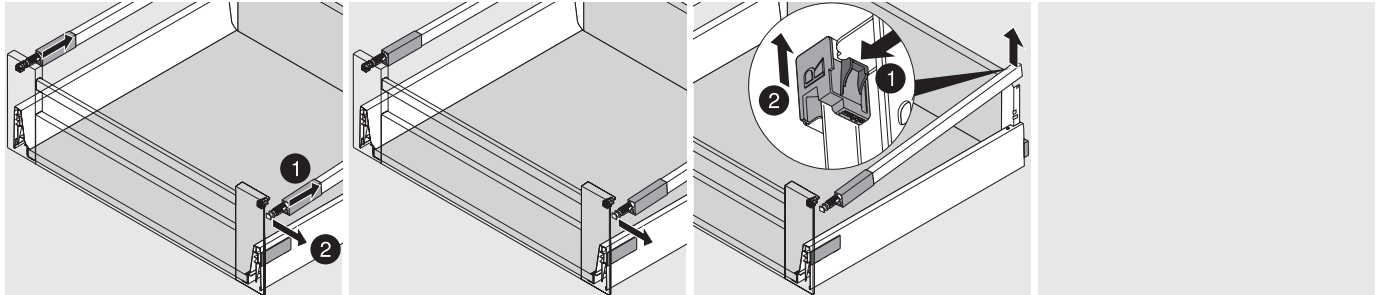

Removal

High fronted pull-out – alu frames

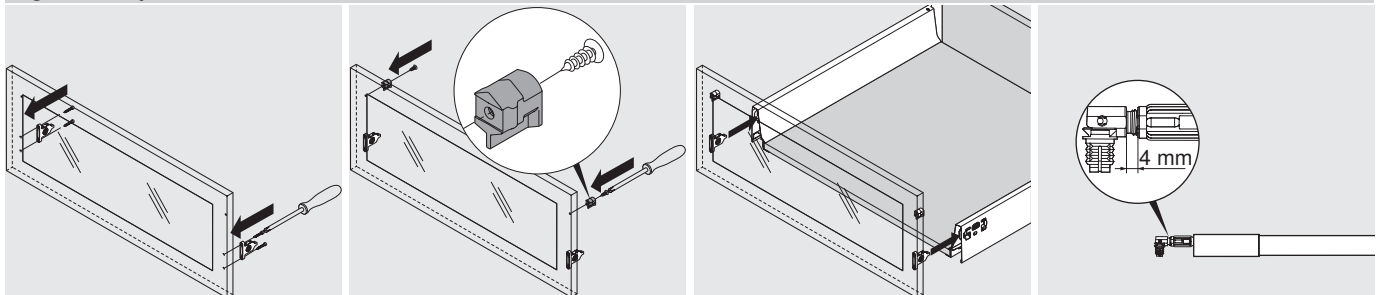



High fronted pull-out – alu frames

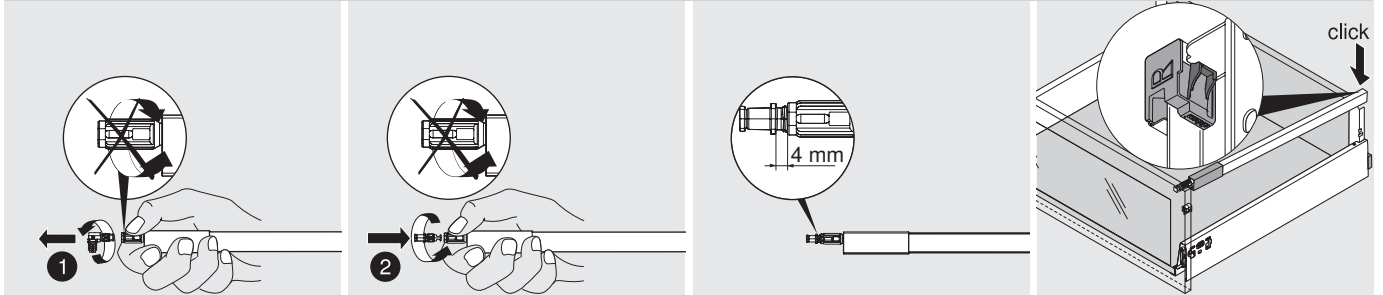

High fronted pull-out – alu frames

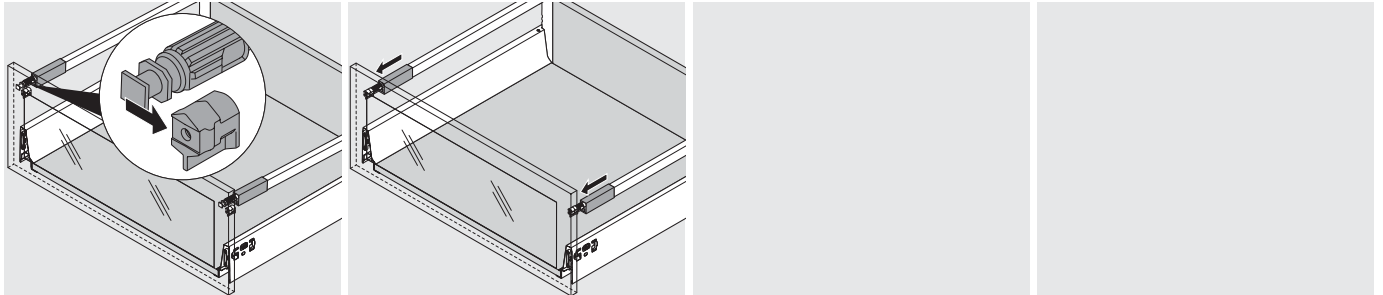

High fronted pull-out – alu frames

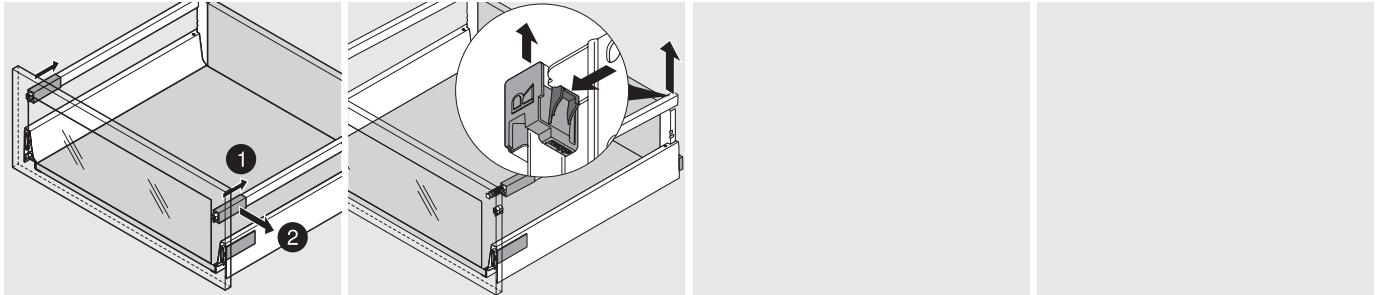

Sink cabinet

