

# MOVENTO runner system

The evolution of motion

# MOVENTO – The evolution of motion



Perfecting motion – This motto has always been the driving force behind the development of our products. We have taken another step forward in this direction with our new runner system MOVENTO: it provides an even more precise runner movement, synchronised, smooth running action as well as new adjustment options.



MOVENTO – The evolution of motion  
See for yourself at [www.blum.com](http://www.blum.com)



## Content

- 4 Perfect motion from opening to closing
- 6 4-dimensional adjustment
- 8 Carrying capacity and stability
- 10 SERVO-DRIVE and TIP-ON
- 12 Applications
- 14 Easy assembly and assembly devices
- 16 Order specification
- 22 The Blum company





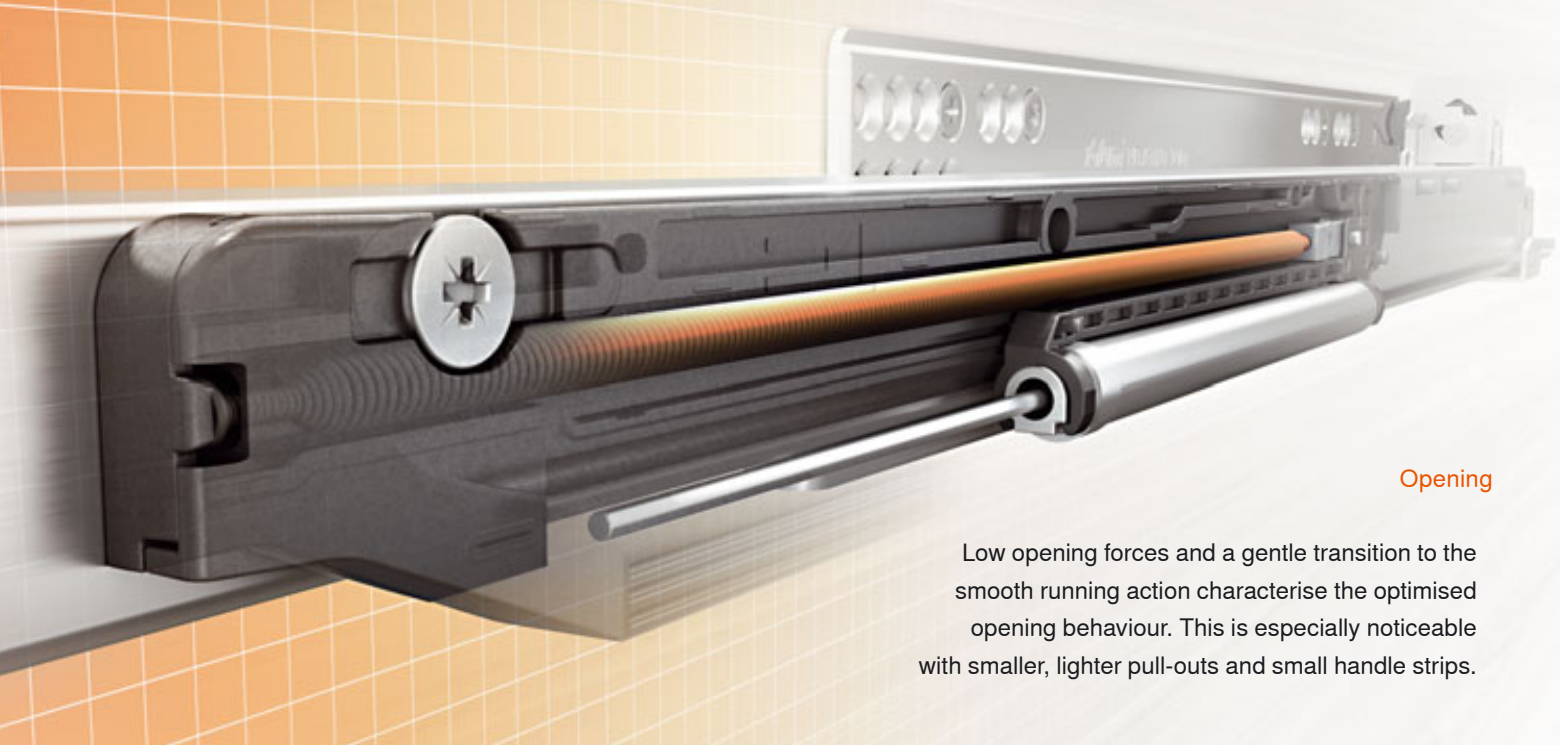

### Opening

Low opening forces and a gentle transition to the smooth running action characterise the optimised opening behaviour. This is especially noticeable with smaller, lighter pull-outs and small handle strips.

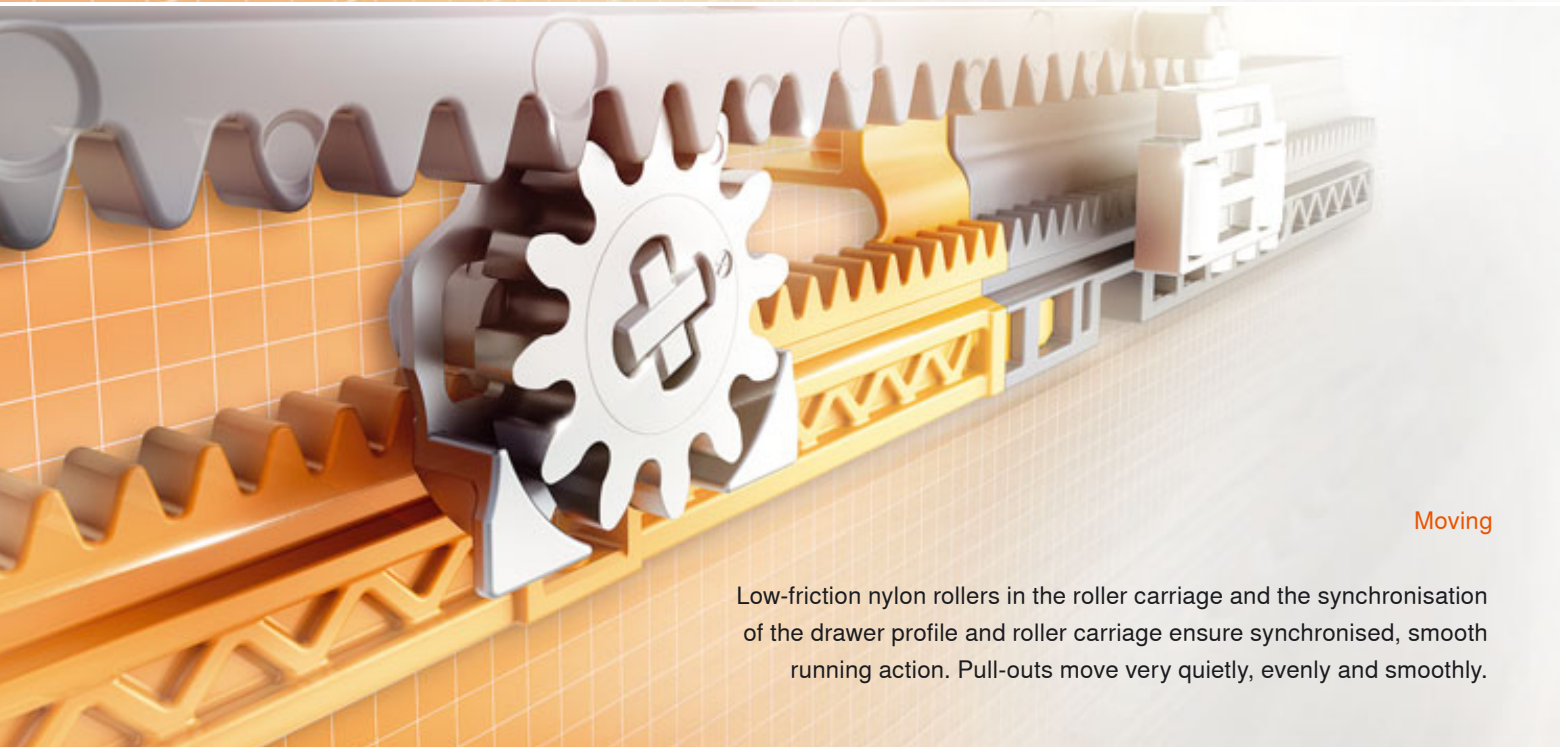

### Moving

Low-friction nylon rollers in the roller carriage and the synchronisation of the drawer profile and roller carriage ensure synchronised, smooth running action. Pull-outs move very quietly, evenly and smoothly.



### Closing

Regardless of how large or heavy the pull-out or how much force is used for closing: Our proven BLUMOTION technology adapts and always ensures silent and effortless closing action.

# 4-dimensional adjustment

## New adjustment dimensions

With MOVENTO, the front can now be adjusted to the side and in the depth along with the height and tilt. Depth adjustment is optional for furniture with inset fronts. An exact gap design can be achieved quickly, easily and tool-free. In addition, no drawer modification is required.



MOVENTO – 4-dimensional adjustment  
See for yourself at [www.blum.com](http://www.blum.com)



Even narrow gaps can be precisely aligned: thanks to 4-dimensional adjustment





1 Side adjustment – carried out via the locking device, a correction to the side adjustment is carried out, if required, behind the runner.



2 Height adjustment



3 Tilt adjustment

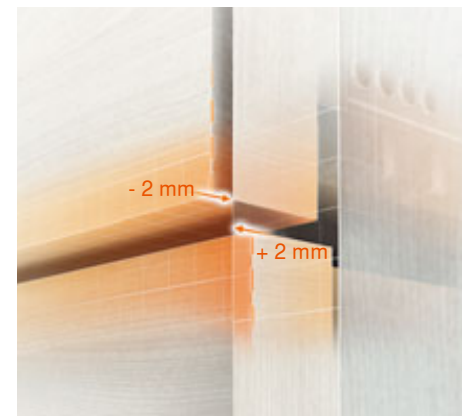

4 Depth adjustment





# Carrying capacity and stability

More possibilities: Thanks to load bearing classes for 40 kg and 60 kg

MOVENTO is available in a 40 kg and 60 kg load bearing class. This opens up numerous possibilities for furniture design such as the use of extra-wide, high and deep pull-outs. This creates lots of storage space that can be filled with heavy items.



More possibilities: Thanks to high stability

The MOVENTO runner is characterised by high stability and excellent sag values. This is a real advantage for applications that are close to the floor. The optional side stabilisation, which is invisible to the furniture user, is ideal for wide pull-outs with short nominal lengths. No manufacturing changes are required for the cabinet or the drawer. The side stabilisation can be combined with the SERVO-DRIVE and TIP-ON opening support systems.

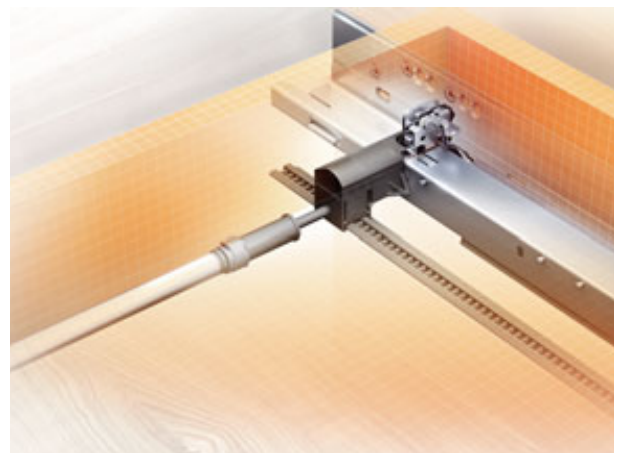

For a high degree of side stability: Our side stabilisation developed specially for wide pull-outs

# SERVO-DRIVE

**SERVO-DRIVE**  
inside

The MOVENTO runner with optional SERVO-DRIVE function

**BLUMOTION**  
inside

Our electrical opening support system SERVO-DRIVE is also an option for the MOVENTO runner with integrated BLUMOTION. It makes opening fascinatingly simple: A light touch is all that's required. This is especially practical for handle-less furniture.

In order to equip the entire kitchen with only one system, SERVO-DRIVE is also available for our AVENTOS lift systems. And whether it's pull-outs or lift systems: BLUMOTION provides silent and effortless closing action.



# TIP-ON

## The MOVENTO runner with optional TIP-ON function



MOVENTO is also available in a version with an integrated TIP-ON function. The integration of the TIP-ON mechanical opening support system ensures that there is no additional space required at the bottom or the back.

For opening, a light press on the handle-less front; for closing, a light push. A synchronisation option is also available (tool-free installation) for secure triggering even for extra-wide fronts. No additional assembly required for the drawer or cabinet.

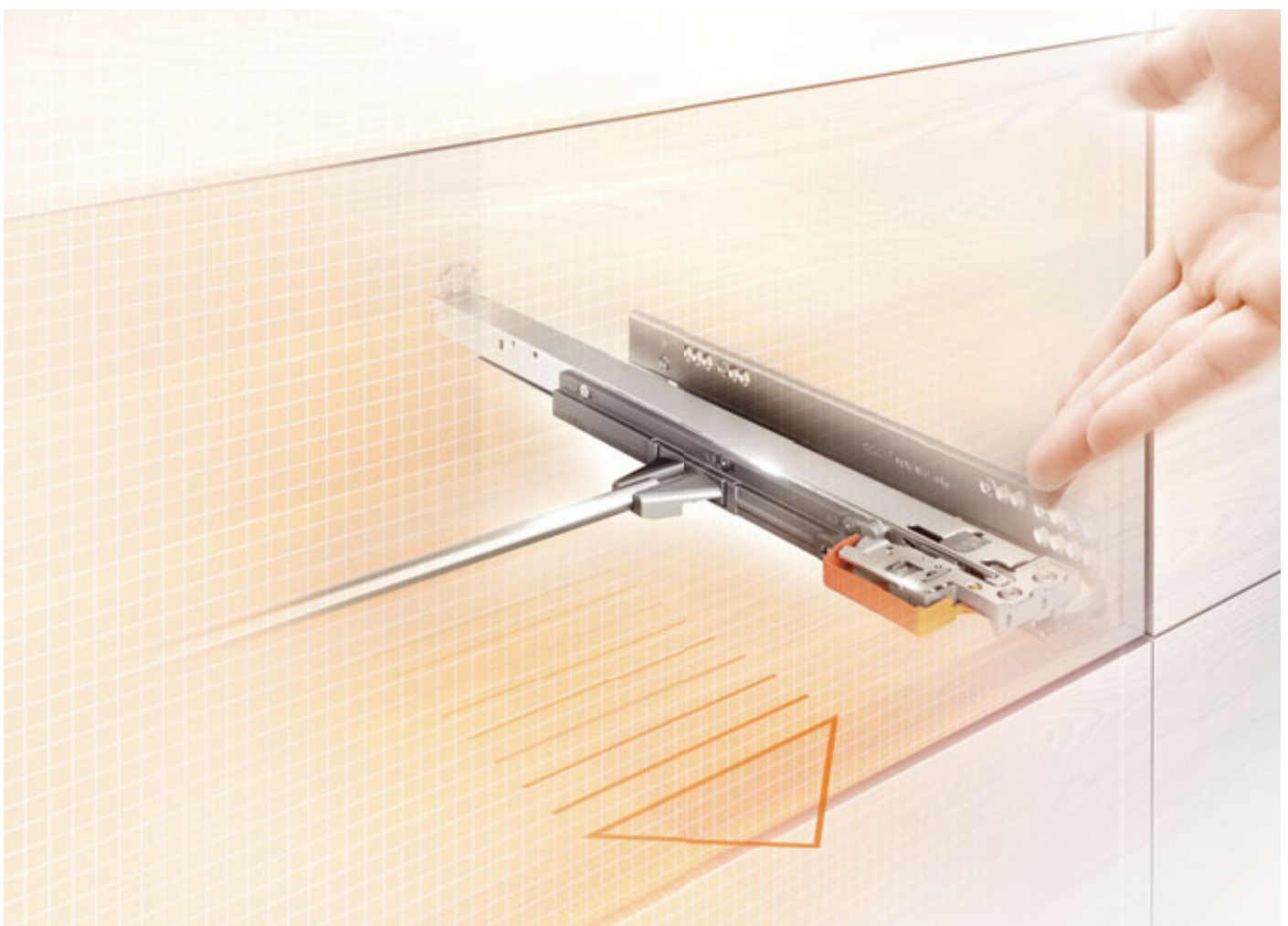





# Applications



MOVENTO opens up numerous design options: e.g. frontals near to the floor, which can be realised thanks to the high stability and the excellent sag values.



## MOVENTO for any living area

MOVENTO was designed specially for the high demands of everyday kitchen use, i.e. for heavy storage items, and frequent opening and closing. However, it is also a good match in any other living area, providing a carrying capacity up to 40 kg and 60 kg, high stability and good runner action.



# Easy assembly

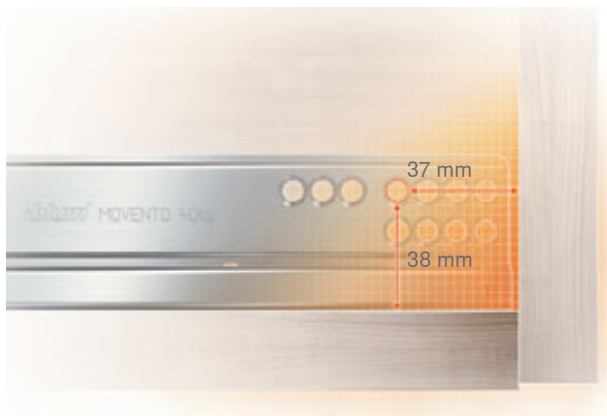

Our development goal: The same fixing position

MOVENTO offers an extensive programme with many options. Assembly is always uniform. Regardless of whether you are combining the runner with BLUMOTION, SERVO-DRIVE, TIP-ON or side stabilisation: The drilling pattern and fixing positions of the cabinet profile always remain the same.

## The possibilities with MOVENTO

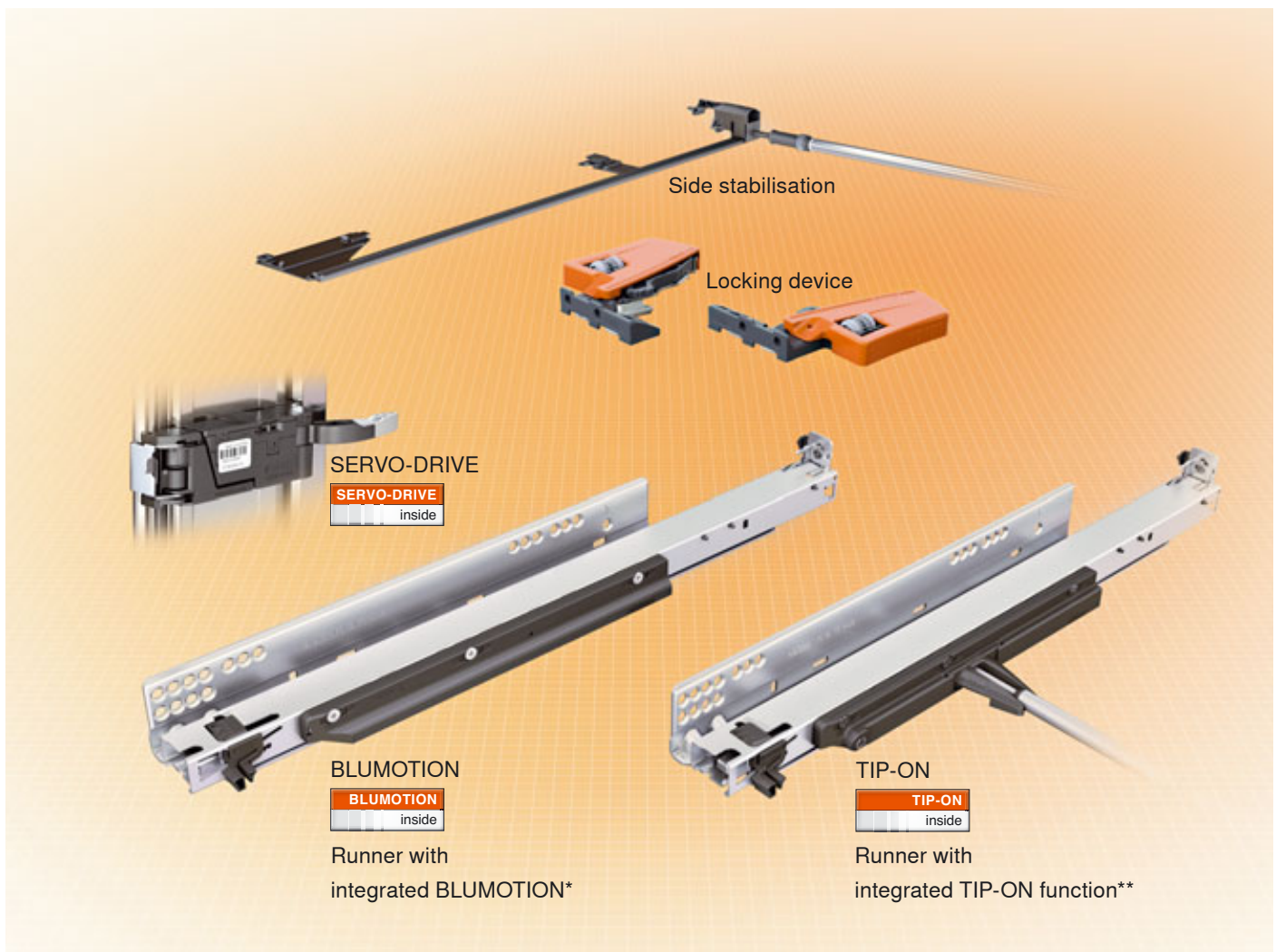

\*Can be combined with SERVO-DRIVE and side stabilisation

\*\*Can be combined with side stabilisation



# Assembly devices



## Continue to use existing devices

Our existing assembly devices can also be used for MOVENTO. Our assembly templates, stops, drilling and insertion machines help ensure fast, simple and easy assembly.

# Order specification

1	Runners left/right			
	BLUMOTION		TIP-ON	
	NL	40 kg	60 kg	40 kg
250 mm	760H2500B		760H2500T	
270 mm	760H2700B		760H2700T	
300 mm	760H3000B		760H3000T	
320 mm	760H3200B		760H3200T	
350 mm	760H3500B		760H3500T	
380 mm	760H3800B		760H3800T	
400 mm	760H4000B		760H4000T	
420 mm	760H4200B		760H4200T	
450 mm	760H4500B	766H4500B	760H4500T	766H4500T
480 mm	760H4800B		760H4800T	
500 mm	760H5000B	766H5000B	760H5000T	766H5000T
520 mm	760H5200B	766H5200B	760H5200T	766H5200T
550 mm	760H5500B	766H5500B	760H5500T	766H5500T
580 mm		766H5800B		766H5800T
600 mm	760H6000B	766H6000B	760H6000T	766H6000T
650 mm		766H6500B		766H6500T
700 mm		766H7000B		766H6500T
750 mm		766H7500B		766H7500T

2	Locking device with side adjustment		
	Nylon/Steel	Orange	T51.7601
	Order left/right		

Depth adjustment left/right (optional)			
	Nylon	RAL 7037 dust grey	298.7600
	Suitable for T51.7601		

3a	TIP-ON synchronisation pinion set (optional)		
	Nylon	RAL 7037 dust grey	T57.7400

3b	TIP-ON synchronisation linkage (optional)	
	Aluminium	ZST.1137W
	For cutting to size, 1.137 mm, for cabinet width KB 1.400 mm	
	<b>Cutting</b>	Inner cabinet width LW - 229 mm

Side stabilisation set		
	For KB 1.400 mm for cutting to size	
	For NL up to 400 mm	ZS7.400MU
	For NL up to 600 mm	ZS7.600MU
	For NL up to 750 mm	ZS7.750MU
<b>Cutting</b>	Inner cabinet width LW - 295 mm	

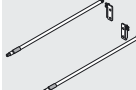
Longside gallery rail with back fixing left/right		
	<b>NL</b>	<b>Chrome plated</b>
	400 mm	ZRE.363A.ID
	450 mm	ZRE.413A.ID
	480 mm	ZRE.443A.ID
	500 mm	ZRE.463A.ID
	520 mm	ZRE.483A.ID
	550 mm	ZRE.513A.ID
	600 mm	ZRE.563A.ID
650 mm	ZRE.613A.ID	

MOVENTO with integrated BLUMOTION

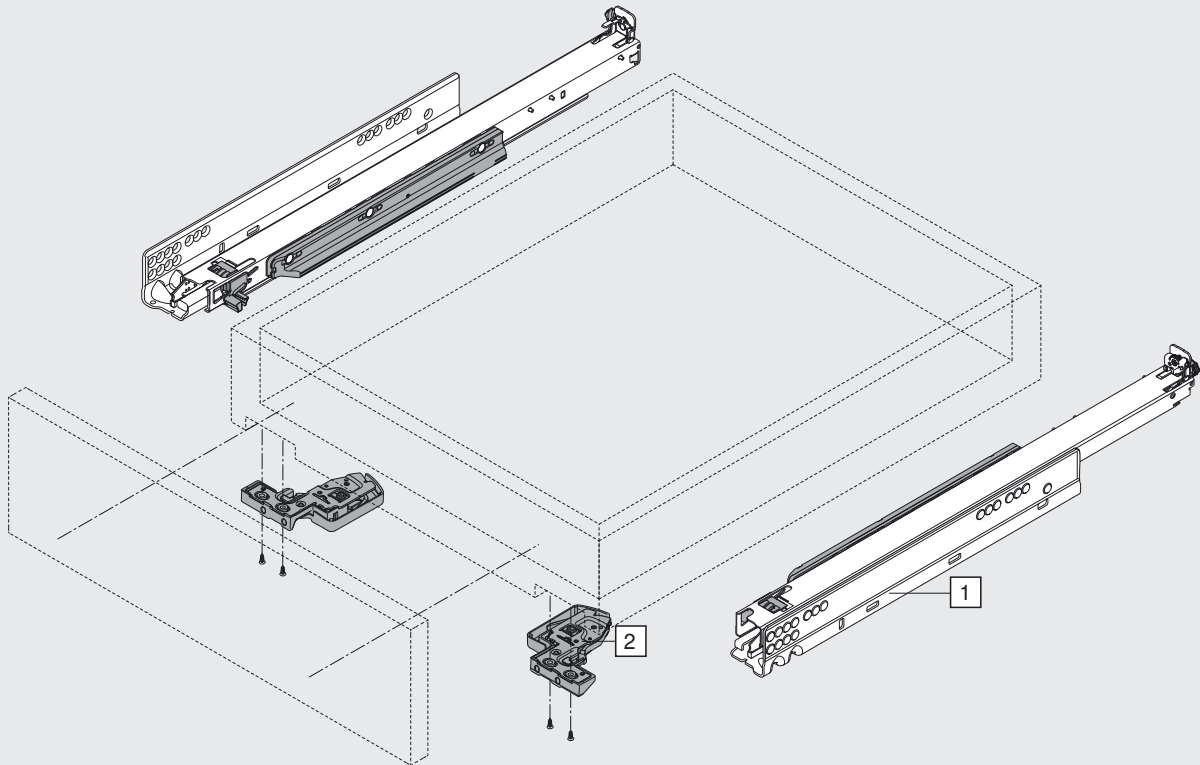

MOVENTO with integrated TIP-ON

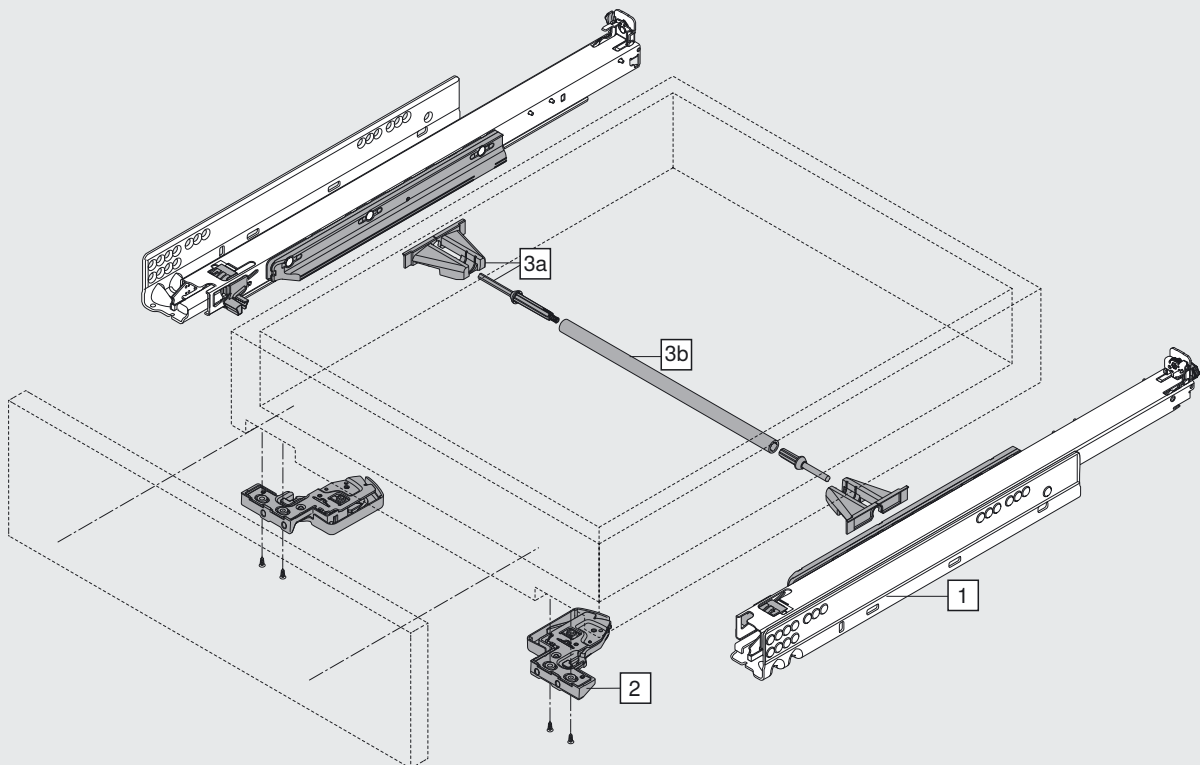



# Order specification

## Drawer/Inner drawer – 760/766H



Space requirements in cabinet	Drawer/Inner drawer	Drawer	Inner drawer
	<p>SKW Internal drawer width</p> <p>LW Inner cabinet width</p>	<p>SKL Drawer length</p> <p>NL Nominal length</p>	<p>ISKL Inner drawer length</p> <p>SKL Drawer length</p> <p>NL Nominal length</p> <p>X Front thickness</p> <p>* + 4 mm with TIP-ON</p> <p>* + 3 mm with depth adjustment</p>

## High fronted pull-out with gallery – 760/766H



Space requirements in cabinet		High fronted pull-out	High fronted pull-out
		<p>SKW Internal drawer width</p> <p>LW Inner cabinet width</p>	<p>SKL Drawer length</p> <p>NL Nominal length</p>

## For all applications

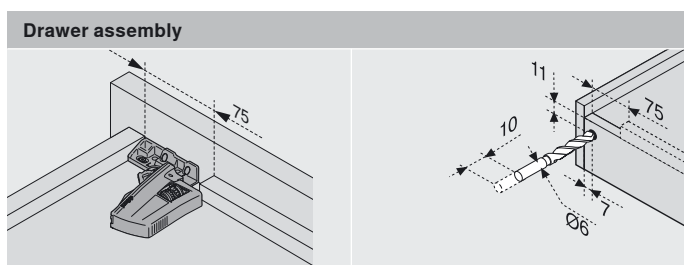

Use drilling template T65.1000.02



### Note

\*\*Limited side adjustment for a drawer side panel thickness of 16 mm, but with full tolerance utilisation of the internal width of the drawer.

### Cabinet profile screw positions – 760H

Nominal length NL (mm)

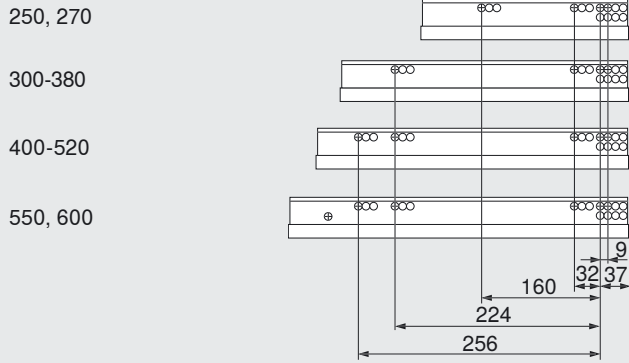

Min. internal cabinet depth = nominal length + 3 mm

### Cabinet profile screw positions – 766H

Nominal length NL (mm)

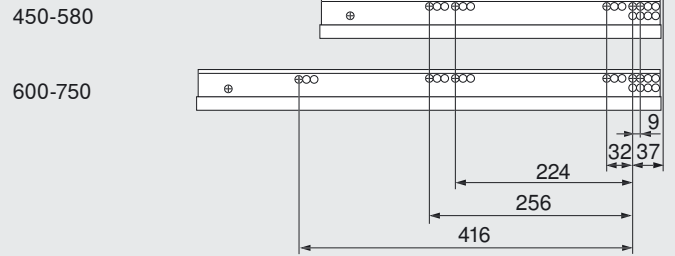

Min. internal cabinet depth = nominal length + 3 mm

### Cabinet profile – 760H

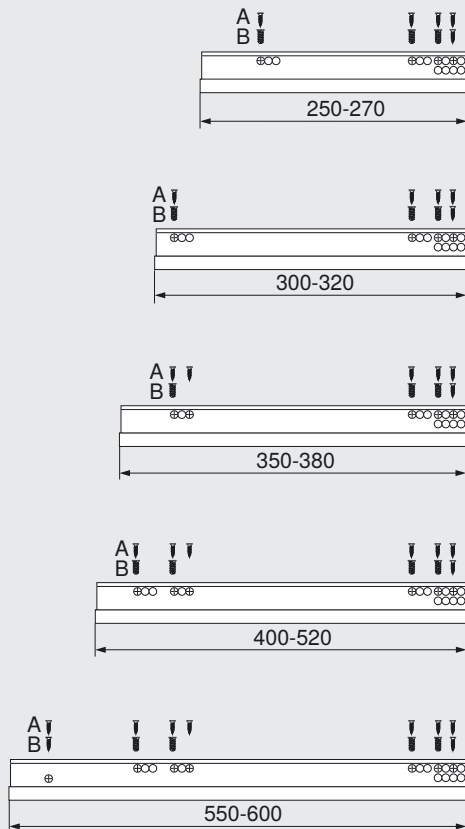

### Cabinet profile – 766H

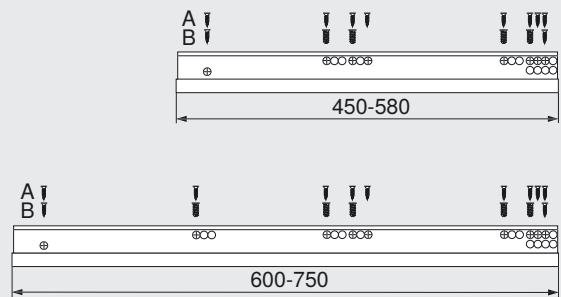

### Fixing onto cabinet

A chipboard screw Ø 3.5 x 15 mm	609.1500
B system screw	661.1450.HG
Back fixing position ensures optimal stability	

### Fixing onto cabinet

A chipboard screw Ø 3.5 x 15 mm	609.1500
B system screw	661.1450.HG
Back fixing position ensures optimal stability	

# Assembly, removal and adjustment

## Locking device

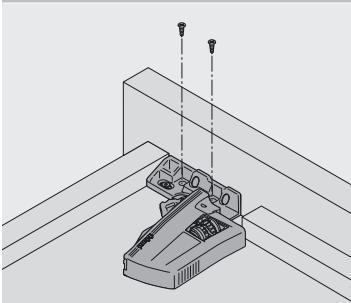

Four sided drawer

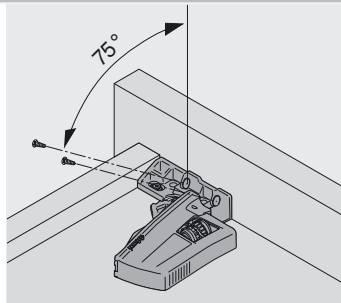

Three sided drawer

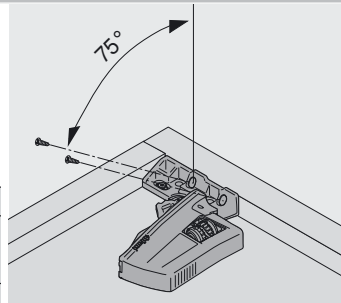

Inner drawer

## Adjustment

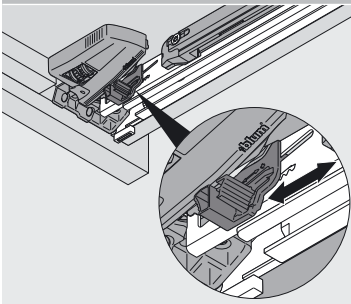

Height adjustment: + 3 mm

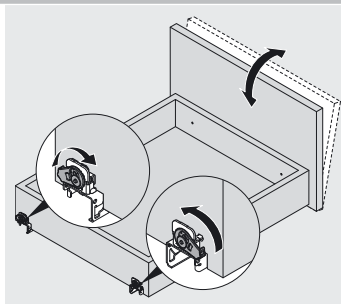

Tilt adjustment

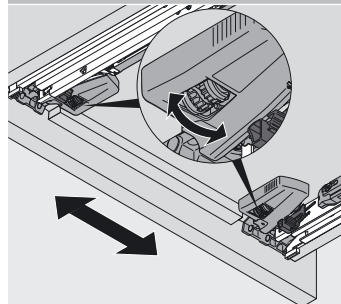

Side adjustment on both sides via the locking device +/- 1.5 mm\*

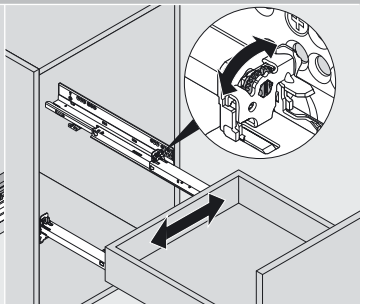

Balance side adjustment via the right, back runner

## High fronted pull-out

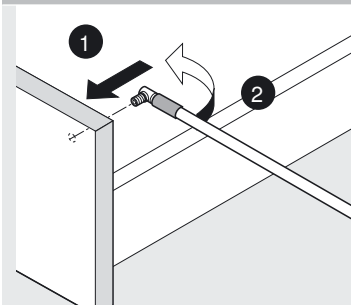

Front assembly

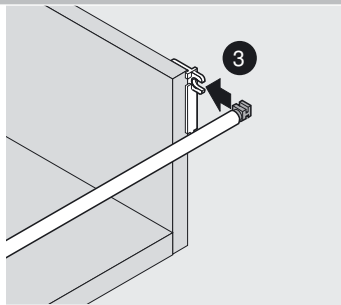

Back assembly

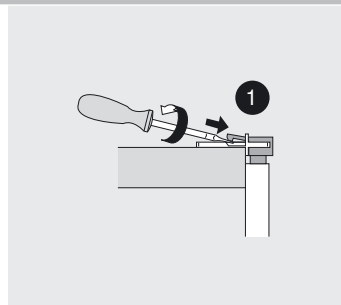

Back removal

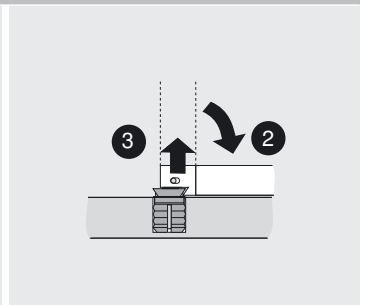

Front removal

## Drawer insertion and removal (760H/766H)

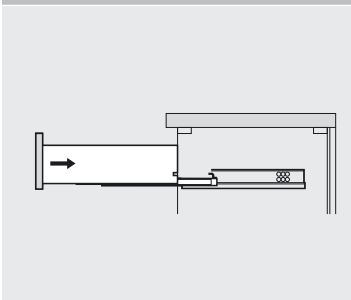

Insertion

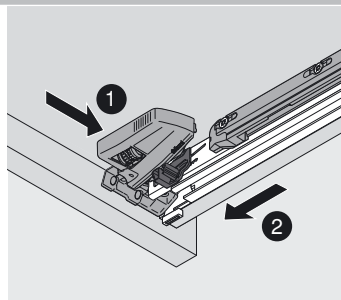
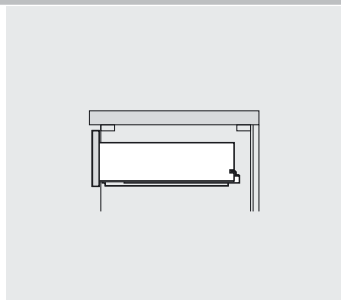

Remove

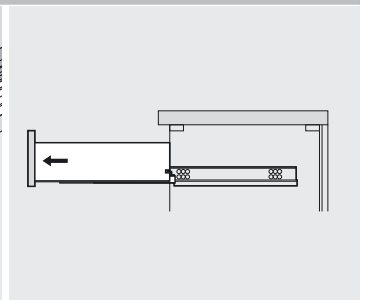

\*Limited side adjustment for a drawer side panel thickness of 16 mm, but with full tolerance utilisation of the internal width of the drawer.



# MOVENTO advantages at a glance

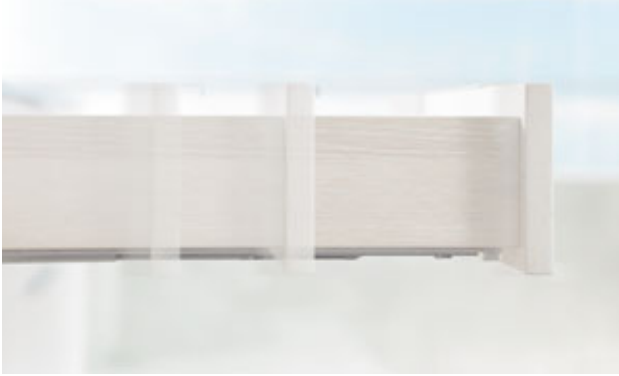

## Motion

New quality of motion – from opening to closing.



## Gap design

New 4-dimensional easy setting option for an exact gap design.



## Load bearing classes

40 kg and 60 kg carrying capacity, excellent sag values and high stability, can be used in many applications.



## Handle-less

SERVO-DRIVE or TIP-ON enables handle-less furniture.



## Well-designed

The MOVENTO runner always has the same fixing position.

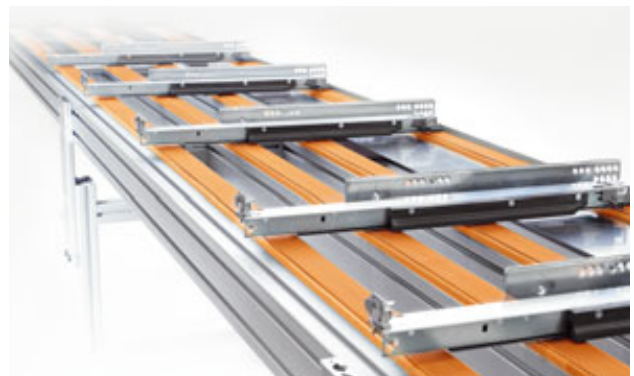

## Quality

For the lifetime of the furniture.

# The Blum company



**1952**



## The first product

The studs are attached to the horseshoe to prevent slipping.

**1958**



## Introduction into the furniture industry

The ANUBA hinge is the first Blum furniture fitting.

**1964**



## Production start

Concealed furniture hinges are produced.

**1966**



## Roller runner

Production of the roller runner begins.

**1985**



## Assembly technology

CLIP hinges can be attached tool-free thanks to CLIP technology.

# Perfecting motion

Fitting solutions from Blum make the opening and closing of furniture an experience to remember. Therefore, we always work long and hard on the development of our lift, hinge, BOX and runner systems to ensure perfect motion.



## DYNAMIC SPACE

Blum products help to optimise workflows, gain storage space and offer a high level of comfort – making kitchens more practical.

## Blum in Austria and worldwide

Over 5000 employees support our efforts of perfecting motion. Our fittings are manufactured at ten locations: seven of which are in Austria, the remaining are in the USA, Brazil and Poland. Thanks to international subsidiaries and sales agencies, Blum is near its customers all around the globe.

## Global customer benefits

From furniture manufacturer to user: Each should profit from the advantages of Blum products.

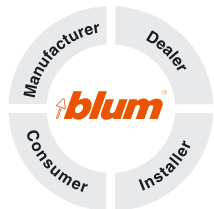

## Quality

Blum products are designed for the requirements of the everyday kitchen and should provide enjoyment for the lifetime of the furniture.



## Innovations

Our fitting solutions should be innovative and make everyday kitchen work easier. Blum conducts much research and the exchange of information with our customers plays an important role here.

## Environment

Protecting the environment is very important at Blum. That's why we use environmentally-friendly processes, intelligent material usage practices and energy-saving measures.



1987



### BOX systems

With METABOX, the first Blum BOX system went into production.

2001

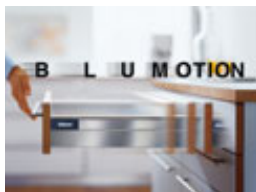

### Dampening

BLUMOTION provides silent and effortless closing action for furniture.

2005



### Lift systems

AVENTOS lift systems are presented for the first time

2007



### Electrical opening support

SERVO-DRIVE has been highly decorated for its design and function.

2011



### Runner systems

With MOVENTO, a new generation of runner systems was born.





Blum U.K.  
Mandeville Drive  
Kingston, Milton Keynes  
GB-Buckinghamshire MK10 0AW  
Tel.: 01908 285700  
Fax: 01908 285701  
E-mail: [info.uk@blum.com](mailto:info.uk@blum.com)

Julius Blum GmbH  
Furniture Fittings Mfg.  
6973 Höchst, Austria  
Tel.: +43 5578 705-0  
Fax: +43 5578 705-44  
E-mail: [info@blum.com](mailto:info@blum.com)  
[www.blum.com](http://www.blum.com)

The Blum logo, consisting of a stylized arrow pointing up and to the right, followed by the word 'blum' in a bold, lowercase, sans-serif font, with a registered trademark symbol (®) to the upper right.

All content is copyrighted by Blum.  
Subject to technical modifications and changes to the range without notice.  
Printed in Austria · ID NO.: 864.362.0 · EP-184/1 EN-GB/09.11-1

LIGHTHOUSE.de